

Model 600A narrow

ARTICULATING BOOM LIFTS



MORE ECONOMIC

- Cut fuel consumption and operating costs with variable engine control.

MORE PRODUCTIVE

- Equipped with hydrostatic drive for easy, precise, infinitely-variable-speed manoeuvrability.

MORE ACCESS

- Conquer rough terrain with standard oscillating axle and four-wheel drive, delivering optimised grip and stability. Work in tighter spaces thanks to compact design with zero tailswing.

SMART DESIGN

- Customer-preferred controls mean fewer buttons and switches used to position the platform and less time spent learning to use the platform controls.



Standard Features

- 0.91 m x 1.83 m low mount platform
- Side entry with drop bar mid rail
- Multiple function operation
- Full proportional drive joystick control with integral thumb steer switch
- Full proportional main boom and swing joystick control
- Multiple speed control for lower boom, telescope and platform rotate
- Selectable creep speed on drive / lift and swing functions
- 180 degree powered platform rotator
- Platform console machine status light panel ¹
- Load sensing system
- AC power cable to platform
- Engine distress warning /shut down system ²
- Two Wheel Drive
- Gull-wing turntable hoods
- 3 degree tilt alarm and indicator light
- 2.13 m narrow frame
- Lifting/tie down lugs
- Hour meter
- Ground control selector switch with key lock
- Platform tool tray
- 12V-DC auxiliary power
- Oscillating front axle
- Low fuel engine cut-out
- Cast Aluminum Control Box
- Horn
- Hydrostatic drive transmission
- Swing-out engine tray
- Interactive Display at Ground Controls
- Control ADE[®] Advanced Design Electronics System
- JLG Skyguard active system

¹ Provides indicator lights at platform control console for system distress, low fuel, tilt light, and foot switch status.

² Low oil pressure and high coolant temperature alarms with shut-down enabled/disabled by analyser.

Standard Specifications

Engine	
• Diesel Engine	Deutz D2011L04 36.4kW
• Fuel Tank Capacity	114 L
Hydraulic system	
• Hydraulic Reservoir	151 L
• Auxiliary Power	12V DC
Tyres	14 x 17.5 Solid Segmented

Accessories & Options

- 0.91 m x 2.44 m slide bar side entry platform
- 0.91 m x 2.44 m Self closing inward swing gate
- 13 mm air line to platform
- On-board 4,000W generator
- SkyPower[®] package 7,500 watt on-board generator
- SkyWelder[®] package 250 amp welder in the platform ⁴
- Nite-Bright[®] package ⁵
- Tow package
- All motion alarm
- Alarm package ⁶
- Light package ⁷
- Head and tail lights
- Flashing amber beacon
- Euro Plug & Socket
- Hostile environment kit ⁸
- Hydraulic oil cooler
- Catalytic Exhaust Purifier
- Soft Touch 0.91 m x 1.83 m Platform Proximity System
- Soft Touch 0.91 m x 2.44 m Platform Proximity System
- Skyguard beacon (ILOS)
- Generator hourmeter
- Synthetic Biodegradable Hydraulic Oil
- Platform worklights
- Special paint colour
- Fixed Axle

⁴ Available when integrated with the SkyPower[®] package

⁵ Consists of six 40-watt lights, four turntable mounted lights and two platform mounted lights.

⁶ Includes all-motion alarm and flashing amber beacon.

⁷ Includes platform mounted work lights and head & tail lights.

⁸ Includes console cover, boom wipers and cylinder bellows.

Model 600A narrow

ARTICULATING BOOM LIFTS

Performance

- Working Height 20.42 m
- Platform Height 18.42 m
- Working Outreach 12.72 m
- Horizontal Outreach 12.07 m
- Up and Over Height 8.09 m
- Swing (Continuous) 360°
- Platform Capacity – Unrestricted 230 kg
- Platform Rotator (Hydraulic) 180°
 - A. Platform Size 0.91 m x 1.83 m
 - B. Overall Width 2.13 m
 - C. Tailswing – working condition 0.13 m
 - D. Stowed Height 2.53 m
 - E. Stowed Length 8.10 m
 - F. Wheelbase 2.44 m
 - G. Ground Clearance 0.28 m
- Machine weight ¹ 10,840 kg
- Maximum Ground Bearing Pressure 6.6 kg/cm²
- Drive Speed 2WD 6.8 km/h
- Gradeability 2WD 30%
- Turning Radius – Inside 4WS 1.56 m
- Turning Radius – Outside 4WS 3.60 m

¹ Certain options or country standards may increase weight and/or dimensions.

² Optional.

Reach Diagram

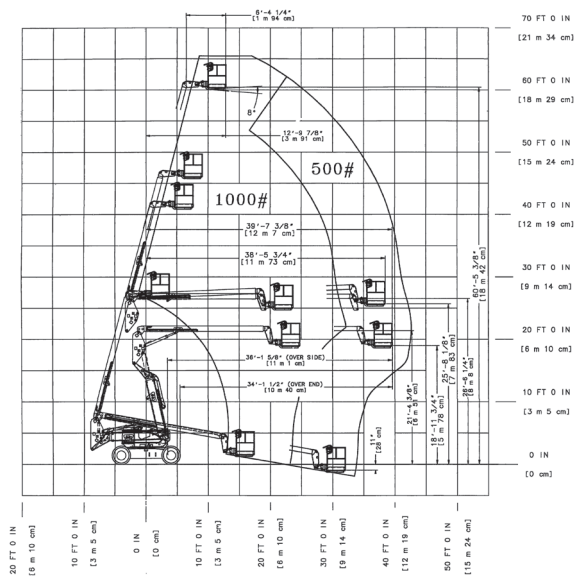

Dimensions

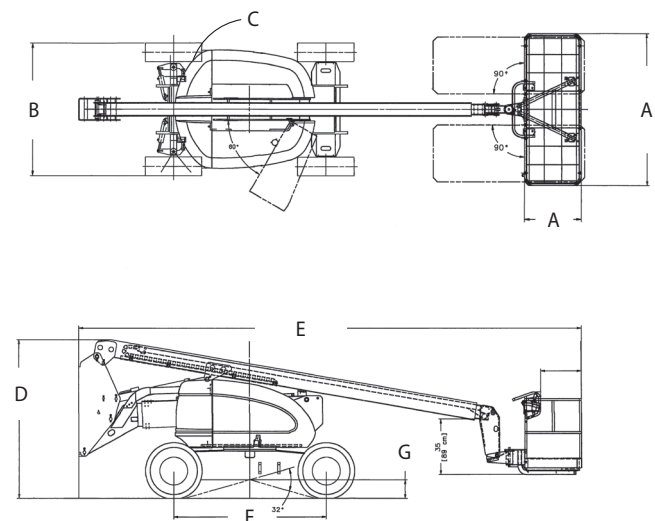

IMPORTANT

JLG is continually researching and developing products and reserves the right to make modifications without prior notice. All data in this document is indicative. Certain options or country standards will increase weight. Specifications may change to meet country standards or with the addition of optional equipment.

Due to continuous product improvements, JLG Industries reserves the right to make specification and/or equipment changes without prior notification.



JLG EMEA BV

Polaris Avenue 63
2132 JH Hoofddorp
The Netherlands
Tel: +31 (0)23 565 5665
Fax: +31 (0)23 557 3750
www.jlg.com

An Oshkosh Corporation Company