

CENTRIFUGAL FANS BLOWERS AND ACCESSORIES

Industrial
Air Technology Corp.



ABOUT US

Industrial Air Technology Corp. services the industrial fan market with a complete line of centrifugal industrial fans and industrial blowers. We understand the rigorous requirements particular to industrial air movement applications. The fans we produce are designed and built for users who value quality craftsmanship and reliable performance. The Industrial Air Technology standard product offering includes backward inclined, industrial exhauster, radially tipped, and high pressure/turbo series fans. We also have a vast offering of **abrasion resistant** options available for material handling fans to provide longer life in abrasive environments, as well as **stainless steel construction** for corrosive and **high temperature** applications for each of our fan models.

VALUE ADDED SERVICES

- Quick delivery of standard and custom fans and accessories
- Expedited shipment services
- FEA and modal analysis
- Online access to our proprietary Fan Performance Curve Generator Program
- Installation and maintenance training
- Complete line of options and accessories
- Customer service product selection assistance
- Custom and made-to-order designs to suit your needs

TABLE OF CONTENTS

Fans and Blowers

GPBI - General Purpose Backward Inclined.....	4
AFSW - Airfoil Single Wide	5
BCHS - Backward Curved High Speed	6
BISW -Backward Inclined Single Wide.....	7
BIDW - Backward Inclined Double Wide	8
IRO (Paddle Wheel) Industrial Exhauster	9
IRF (Flat Back Plate) Industrial Exhauster	10
IRW (Radial Blade) Industrial Exhauster	11
IRV (Radial Blade) Industrial Exhauster	12
IRT (Radial Tip) Industrial Exhauster	13
RTS - Radially Tipped.....	14
PB - Pressure Blowers	15
BCLS - Backward Curved Lower Volume	16
TROH - Turbo Radial Open High (Volume).....	17
TROL - Turbo Radial Open Low (Volume).....	18
Fan Drive Arrangements	19 - 21
Options.....	22 - 23
Dampers – Inlet and Outlet	24 - 25
Accessories	
Screens	26
Inlet Boxes	26
Silencers	26
Weather Hoods	26
Flexible Connectors.....	27
Transitions - Inlet and Outlet.....	27
Fan Bases	27
Sensors.....	28
Vibration Isolators	28
Insulation.....	28

GPBI—GENERAL PURPOSE BACKWARD INCLINED

Economical, modular design allows for short lead times and a competitive price while offering similar performance to our BISW line up to AMCA Class 3.

- Sizes 12 1/4" – 36 1/2" wheel diameter
- AMCA class 1, 2 & 3
- Volume up to 47,000 CFM
- Pressure up to 18.5" WG
- Temperature range -30°F to 600°F
- Arrangements 1, 4, 4V, 8, 9, 10



WHEEL TYPE GPBI

Aluminum Wheel

- For clean air applications at all volumes
- Tapered shroud
- Backward inclined blades
- Operating temperatures up to 200°F
- Riveted construction

Steel Wheel

- For relatively clean air applications with little or no particulate
- Tapered shroud
- Backward inclined blades
- Operating temperatures up to 600°F
- Welded construction



Steel Wheel Option

GPBI

- A. Continuously welded steel housing
- B. Reversible / rotatable housing in 45° increments
- C. All wheels are balanced to grade G6.3 or better
- D. Shafting is 1045 bearing grade TG&P
 - Sized for the first critical speed to be 1.25 times the max speed or higher
- E. Anti-friction flange bearings
 - Reduced shaft sizes
 - Better support of overhung loads
 - Provides shaft seal
 - Premium grease lubrication
 - Rated bearing life (L10) of 100,000 hours
- F. Inlet (flange style shown)
- G. Flanged outlet with mounting holes
- H. Lifting lugs for use in installation

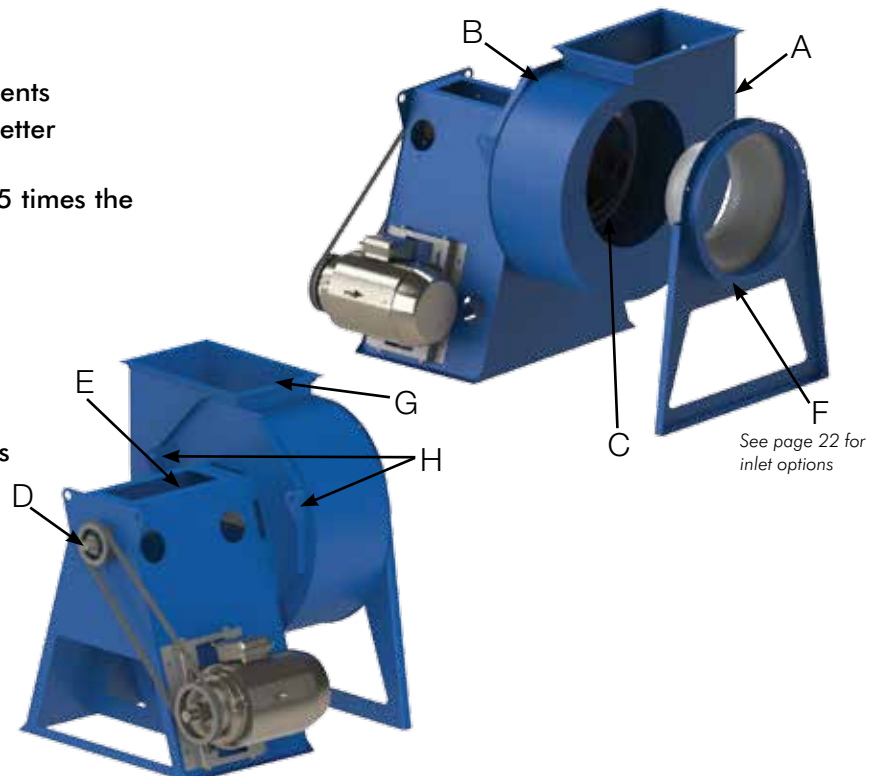

ADDITIONAL FEATURES

- Extended lubrication lines for easy maintenance
- Standard IATC blue enamel paint

CONSTRUCTION FEATURES

AFSW-AIRFOIL SINGLE WIDE

Wheels have aerodynamically shaped blades providing non-overloading, highly efficient performance for relatively clean air applications.

- Sizes 18 1/4" – 89" wheel diameter
- AMCA class 2, 3 & 4
- Volume up to 315,000 CFM
- Pressure up to 26" WG
- Temperature range -30°F to 800°F
- Arrangements 1, 3, 4, 4V, 7, 8, 9

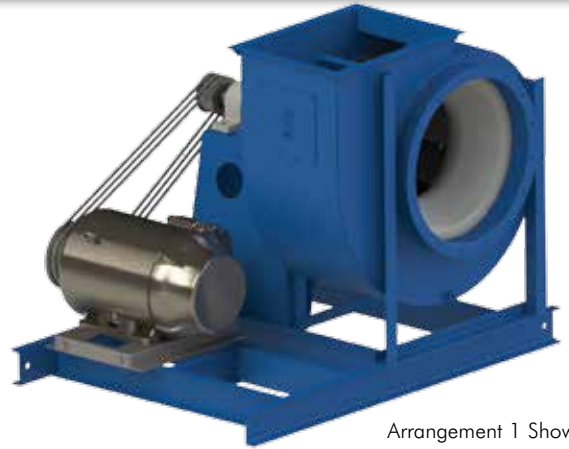

Arrangement 1 Shown

WHEEL TYPE AFSW

Steel Wheel

- For relatively clean air applications with little or no particulate
- Tapered shroud
- Airfoil shaped backward inclined blades
- Operating temperatures up to 800°F



AFSW

- A. Continuously welded steel housing
- B. Fixed housing with any discharge angle
- C. All wheels are balanced to grade G6.3 or better
- D. Shafting is 1045 bearing grade TG&P
 - Sized for the first critical speed to be 1.25 times the max speed or higher
- E. Anti-friction pillow block bearings
 - Premium grease lubrication
 - Rated bearing life (L10) of 100,000 hours
- F. Inlet (flange style shown)
- G. Flanged outlet with mounting holes

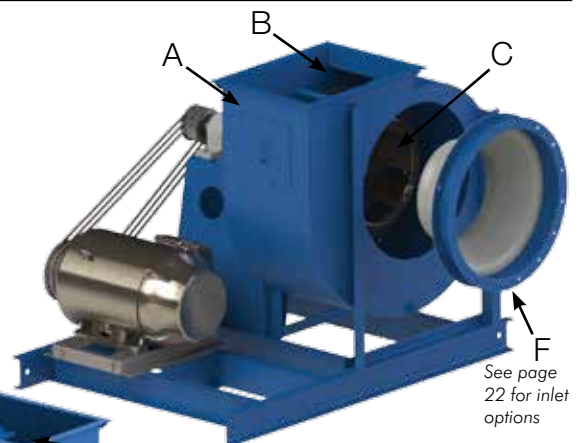

See page 22 for inlet options

ADDITIONAL FEATURES

- Lifting lugs for use in installation
- Extended lubrication lines for easy maintenance
- Standard IATC blue enamel paint

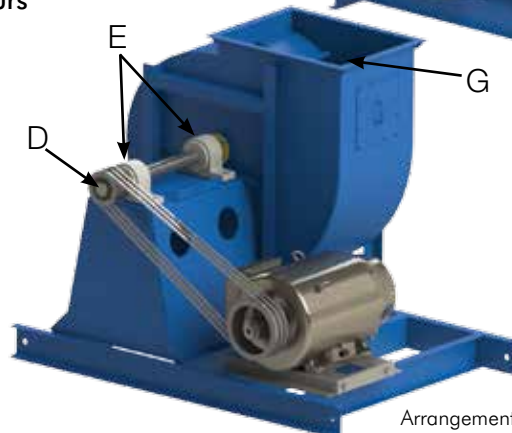

Arrangement 1 Shown

BCHS—BACKWARD CURVED HIGH SPEED

Wheels have backward curved blades providing non-overloading, highly efficient performance for relatively clean air applications.

- Sizes 18 3/4" – 90 3/4" wheel diameter
- Construction class 30 & 40
- Volume up to 215,000 CFM
- Pressure up to 42" WG
- Temperature range -30°F to 800°F
- Arrangements 1, 3, 7, 8, & 9



Arrangement 1 Shown

WHEEL TYPE BCBS

Steel Wheel

- For relatively clean air applications with little or no particulate
- Tapered shroud
- Backward curved blades
- Operating temperatures up to 800°F



BCBS

- A. Continuously welded steel housing
- B. Fixed housing with any discharge angle
- C. All wheels are balanced to grade G6.3 or better
- D. Shafting is 1045 bearing grade TG&P
 - Sized for the first critical speed to be 1.25 times the max speed or higher
- E. Anti-friction pillow block bearings
 - Premium grease lubrication
 - Rated bearing life (L10) of 100,000 hours
- F. Inlet (flange style shown)
- G. Flanged outlet with mounting holes

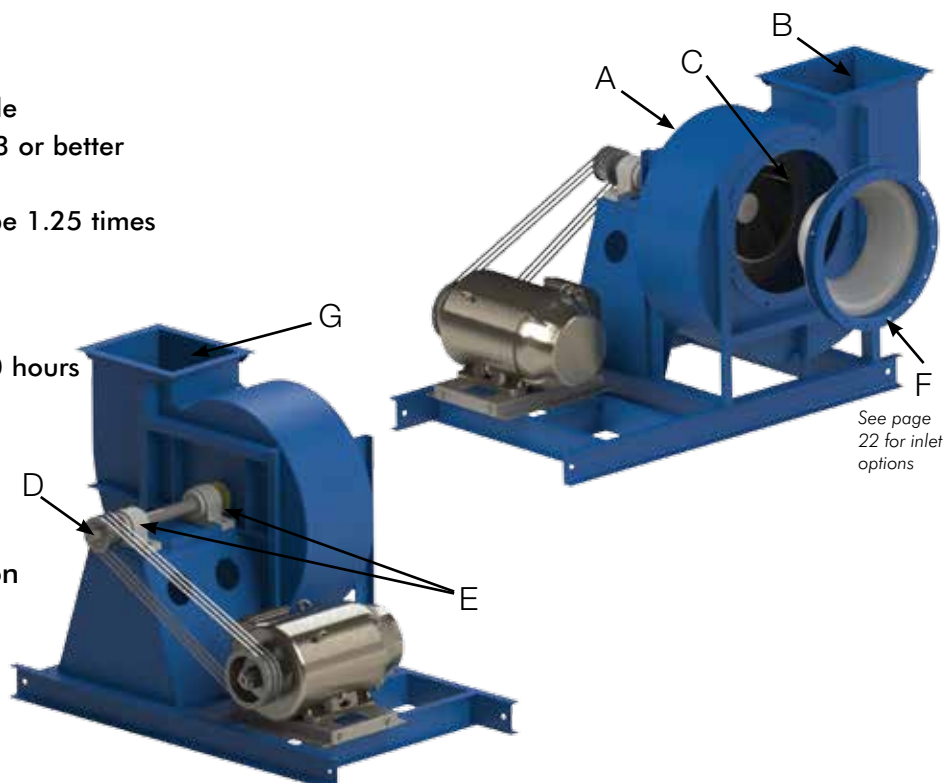

See page 22 for inlet options

ADDITIONAL FEATURES

- Lifting lugs for use in installation
- Extended lubrication lines for easy maintenance
- Standard IATC blue enamel paint

CONSTRUCTION FEATURES

BISW-BACKWARD INCLINED SINGLE WIDE

Wheels have flat, backwardly inclined, single thickness blades. Non-overloading high efficiency design generates low to moderate pressures.

- Sizes 12 1/4" – 98 1/4" wheel diameter
- AMCA class 2, 3, 4 & 5
- Volume up to 445,00 CFM
- Pressure up to 28" WG
- Temperature range -30°F to 800°F
- Arrangements 1, 3, 4, 4V, 7, 8, 9

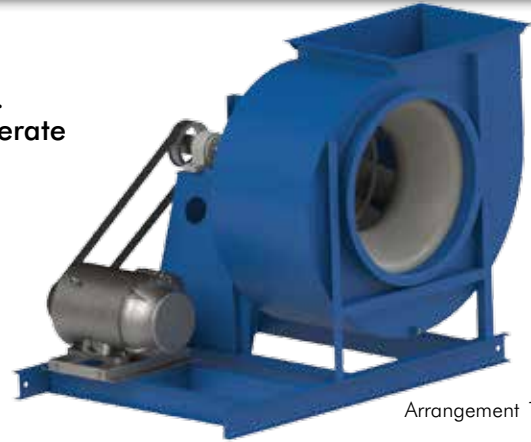

Arrangement 1 Shown

WHEEL TYPE BISW

Steel Wheel

- For relatively clean air applications with little or no particulate
- Tapered shroud
- Flat, backwardly inclined, single thickness blades
- Operating temperatures up to 800°F



BISW

- A. Continuously welded steel housing
- B. Fixed housing with any discharge angle
- C. All wheels are balanced to grade G6.3 or better
- D. Shafting is 1045 bearing grade TG&P
 - Sized for the first critical speed to be 1.25 times the max speed or higher
- E. Anti-friction pillow block bearings
 - Premium grease lubrication
 - Rated bearing life (L10) of 100,000 hours
- F. Inlet (flange style shown)
- G. Flanged outlet with mounting holes

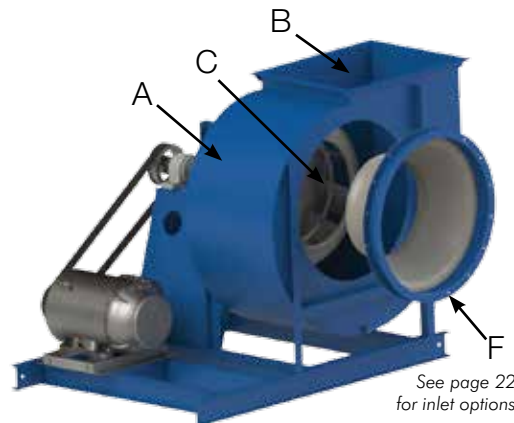

See page 22 for inlet options

ADDITIONAL FEATURES

- Lifting lugs for use in installation
- Extended lubrication lines for easy maintenance
- Standard IATC blue enamel paint

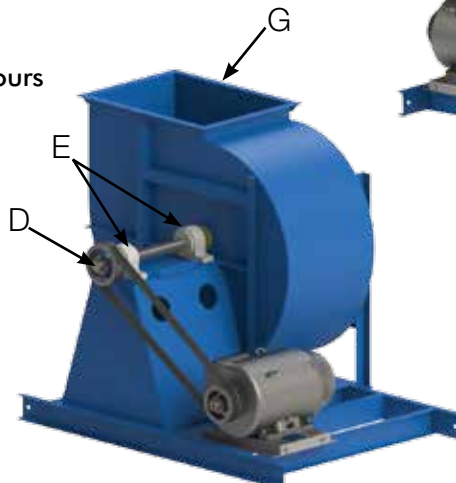

BIDW-BACKWARD INCLINED DOUBLE WIDE

Wheels have flat, backwardly inclined, single thickness blades
Non-overloading high efficiency design used for relatively clean air applications with little or no particulate in the airstream.

- Sizes 18 1/4" – 73" wheel diameter
- AMCA class 2 & 3
- Volume up to 330,000 CFM
- Pressure up to 18" WG
- Temperature range -30°F to 200°F
- Arrangements 3 & 7



Arrangement 3 Shown

WHEEL TYPE BIDW

Steel Wheel

- For relatively clean air applications with little or no particulate
- Tapered shroud
- Backward inclined blades
- Operating temperatures up to 200°F



BIDW

- A. Continuously welded steel housing
- B. Fixed housing with any discharge angle
- C. All wheels are balanced to grade G6.3 or better
- D. Shafting is 1045 bearing grade TG&P
 - Sized for the first critical speed to be 1.25 times the max speed or higher
- E. Anti-friction pillow block bearings
 - Premium grease lubrication
 - Rated bearing life (L10) of 100,000 hours
- F. Open inlet
- G. Flanged outlet with mounting holes

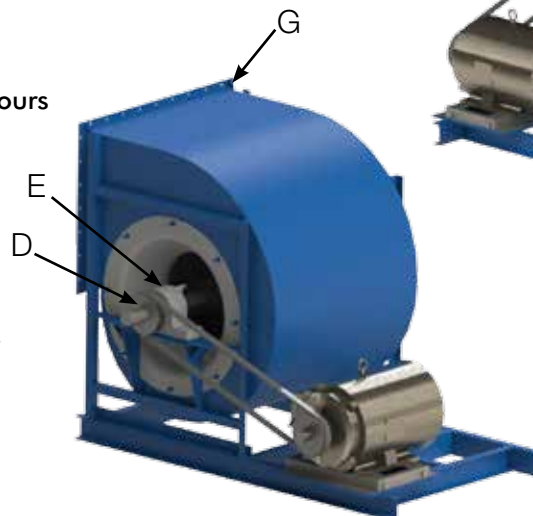
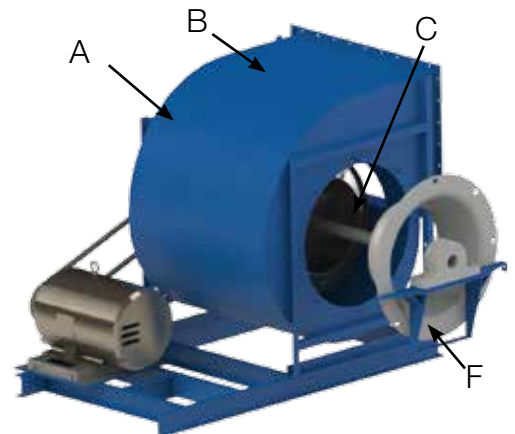

ADDITIONAL FEATURES

- Lifting lugs for use in installation
- Extended lubrication lines for easy maintenance
- Standard IATC blue enamel paint

Arrangement 3 Shown

CONSTRUCTION FEATURES

IRO (PADDLE WHEEL) INDUSTRIAL EXHAUSTER SERIES

Paddle wheel design used for light to medium material handling applications where moderate pressure and CFM are required.

- Sizes 12 1/4" – 85 1/4" wheel diameter
- Construction class 15, 30 & 50
- Volume up to 200,000 CFM
- Pressure up to 50" WG
- Temperature Range -30°F to 1000°F
- Arrangements 1, 8, & 9



Arrangement 1 Shown

WHEEL TYPE IRO

Steel Wheel

- For light to medium material handling applications
- No shroud
- Flat radial blades
- Operating temperatures up to 1000°F
- Wear liners or abrasion resistant materials available



IRO

- A. Continuously welded steel housing
- B. Fixed housing with any discharge angle
- C. All wheels are balanced to grade G6.3 or better
- D. Shafting is 1045 bearing grade TG&P
 - Sized for the first critical speed to be 1.25 times the max speed or higher
- E. Anti-friction pillow block bearings
 - Premium grease lubrication
 - Rated bearing life (L10) of 40,000 hours
- F. Inlet (flange style shown)
- G. Flanged outlet with mounting holes

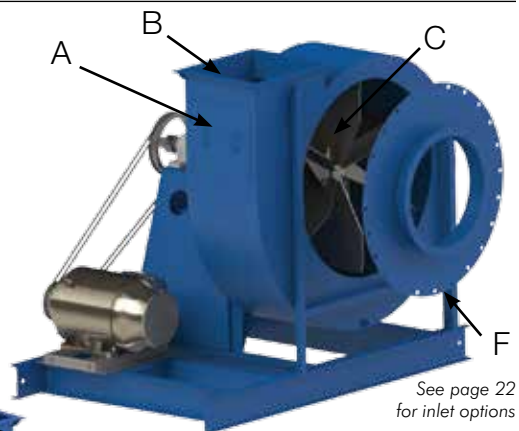

See page 22 for inlet options

ADDITIONAL FEATURES

- Lifting lugs for use in installation
- Extended lubrication lines for easy maintenance
- Standard IATC blue enamel paint

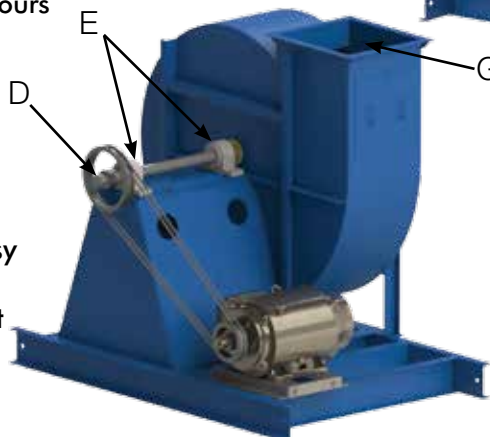

IRF (FLAT BACK PLATE) INDUSTRIAL EXHAUSTER SERIES

Wheel with flat radial blades and flat back plate design prevent stringy or fibrous material from hanging up and wrapping around the blades, and used for light to medium material handling applications.

- Sizes 12 1/4" – 57 1/4" wheel diameter
- Construction class 15, 30 & 50
- Volume up to 92,000 CFM
- Pressure up to 45" WG
- Temperature Range -30°F to 1000°F
- Arrangements 1, 4, 4V, 8, & 9

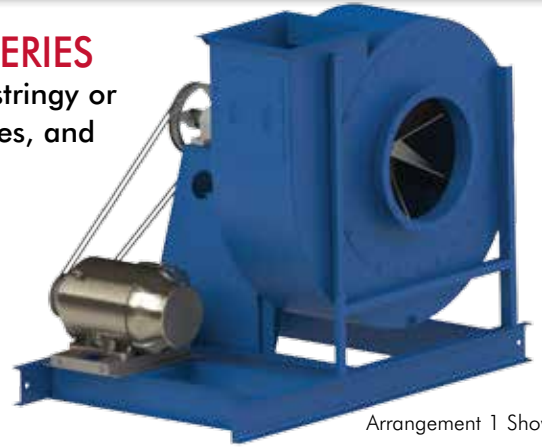

Arrangement 1 Shown

WHEEL TYPE IRF

Steel Wheel

- For light to medium, stringy or fibrous material handling applications
- Flat back plate
- Flat radial blades
- Operating temperatures up to 1000°F
- Wear liners or abrasion resistant materials available



IRF

- A. Continuously welded steel housing
- B. Fixed housing with any discharge angle
- C. All wheels are balanced to grade G6.3 or better
- D. Shafting is 1045 bearing grade TG&P
 - Sized for the first critical speed to be 1.25 times the max speed or higher
- E. Anti-friction pillow block bearings
 - Premium grease lubrication
 - Rated bearing life (L10) of 40,000 hours
- F. Inlet (flange style shown)
- G. Flanged outlet with mounting holes

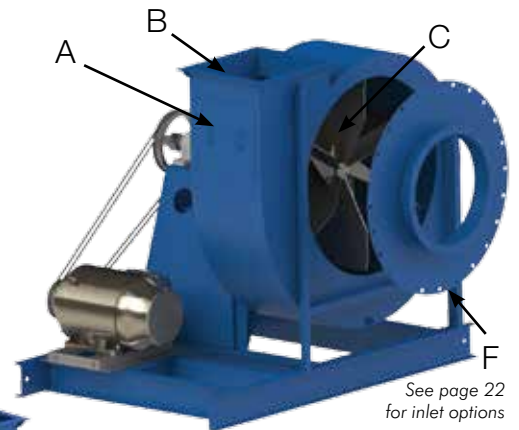

See page 22 for inlet options

ADDITIONAL FEATURES

- Lifting lugs for use in installation
- Extended lubrication lines for easy maintenance
- Standard IATC blue enamel paint

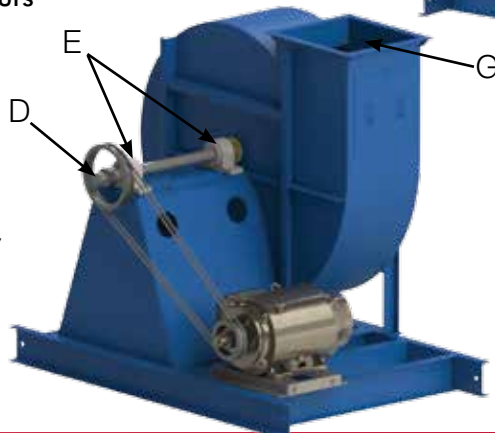

CONSTRUCTION FEATURES

IRW (RADIAL) INDUSTRIAL EXHAUSTER SERIES

Back plated and box gusseted wheels are used for moderate pressure and for heavier fibrous material handling (paper, plastic, metal, and wood).

- Sizes 19" – 36 ½" wheel diameter
- Construction class 30 & 50
- Volume up to 35,000 CFM
- Pressure up to 45" WG
- Temperature range -30°F to 1000°F
- Arrangements 1, 4, 8, & 9



Arrangement 1 Shown

WHEEL TYPE IRW

Steel Wheel

- For moderate to heavy fibrous material handling applications
- Flat back plate
- Flat radial blade with box gussets
- Operating temperatures up to 1000°F
- Abrasion resistant materials available

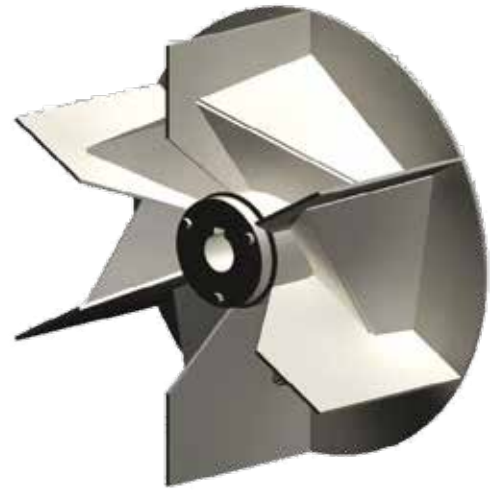

IRW

- A. Continuously welded steel housing
- B. Fixed housing with any discharge angle
- C. All wheels are balanced to grade G6.3 or better
- D. Shafting is 1045 bearing grade TG&P
 - Sized for the first critical speed to be 1.25 times the max speed or higher
- E. Anti-friction pillow block bearings
 - Premium grease lubrication
 - Rated bearing life (L10) of 40,000 hours
- F. Inlet (flange style shown)
- G. Flanged outlet with mounting holes

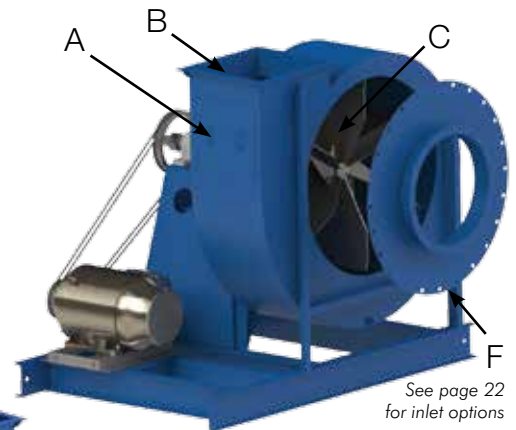

See page 22
for inlet options

ADDITIONAL FEATURES

- Lifting lugs for use in installation
- Extended lubrication lines for easy maintenance
- Standard IATC blue enamel paint

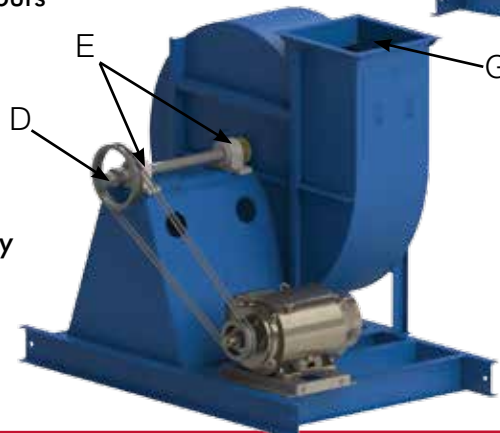

IRV (RADIAL) INDUSTRIAL EXHAUSTER SERIES

Wheels back plated with machined blade edges and bull-nose hub for stringy material handling applications.

- Sizes 19" – 36 ½" wheel diameter
- Construction class 30 & 50
- Volume up to 35,000 CFM
- Pressure up to 45" WG
- Temperature range -30°F to 1000°F
- Arrangements 1, 4, 8, & 9



Arrangement 1 Shown

WHEEL TYPE IRV

Steel Wheel

- For light to medium material handling applications
- Flat back plate
- Flat radial blades with machined leading edge with box gussets
- Operating temperatures up to 1000°F
- Chopper wheel design
- Abrasion resistant materials available

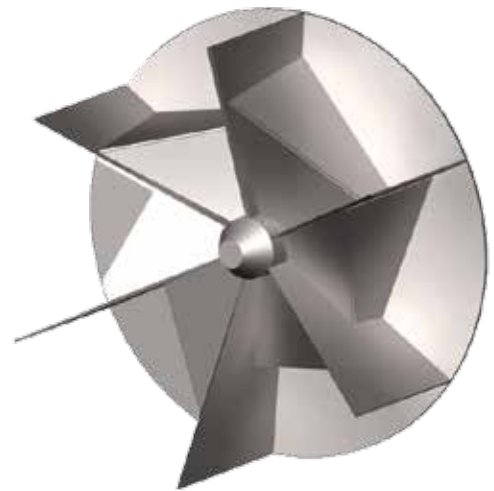

IRV

- A. Continuously welded steel housing
- B. Fixed housing with any discharge angle
- C. All wheels are balanced to grade G6.3 or better
- D. Shafting is 1045 bearing grade TG&P
 - Sized for the first critical speed to be 1.25 times the max speed or higher
- E. Anti-friction pillow block bearings
 - Premium grease lubrication
 - Rated bearing life (L10) of 40,000 hours
- F. Inlet (flange style shown)
- G. Flanged outlet with mounting holes

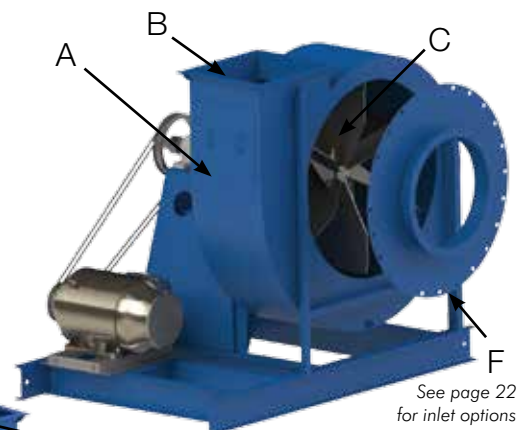

See page 22
for inlet options

ADDITIONAL FEATURES

- Lifting lugs for use in installation
- Extended lubrication lines for easy maintenance
- Standard IATC blue enamel paint

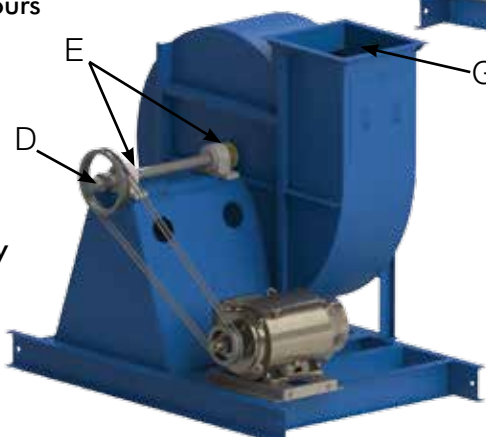

CONSTRUCTION FEATURES

IRT (RADIAL TIP) INDUSTRIAL EXHAUSTER SERIES

Radial tip designed wheels are used for moderate pressure for higher efficiency in moderately dust-laden air.

- Sizes 19 1/8" – 85 1/4" wheel diameter
- Construction class 15, 30 & 50
- Volume up to 140,000 CFM
- Pressure up to 45" WG
- Temperature range -30°F to 1000°F
- Arrangements 1, 3, 4, 7, 8, & 9



Arrangement 1 Shown

WHEEL TYPE IRT

Steel Wheel

- For light to medium dust laden applications
- Tapered shroud
- Radial tip blades
- Operating temperatures up to 1000°F
- Abrasion resistant materials available



IRT

- A. Continuously welded steel housing
- B. Fixed housing with any discharge angle
- C. All wheels are balanced to grade G6.3 or better
- D. Shafting is 1045 bearing grade TG&P
 - Sized for the first critical speed to be 1.25 times the max speed or higher
- E. Anti-friction pillow block bearings
 - Premium grease lubrication
 - Rated bearing life (L10) of 40,000 hours
- F. Inlet (flange style shown)
- G. Flanged outlet with mounting holes

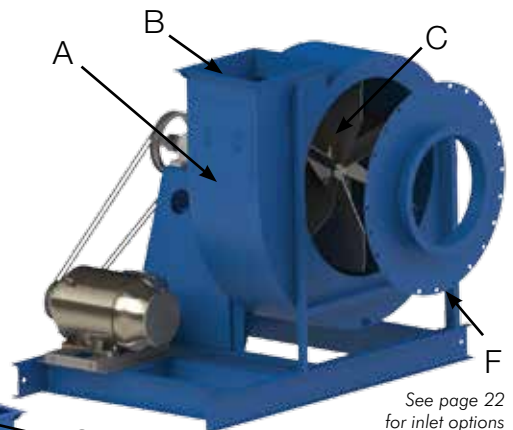

See page 22 for inlet options

ADDITIONAL FEATURES

- Lifting lugs for use in installation
- Extended lubrication lines for easy maintenance
- Standard IATC blue enamel paint

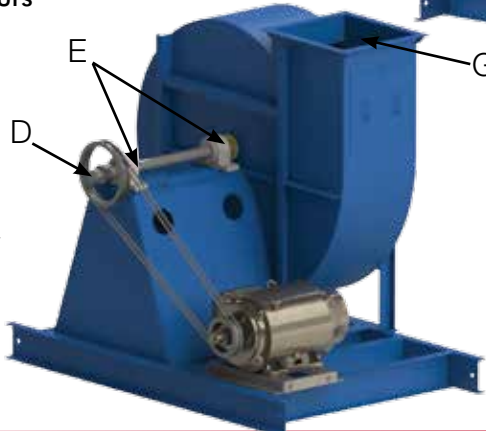

RTS-RADIALLY TIPPED

Wheels are a heavy duty, high efficiency design suitable for applications involving large volume gas streams at moderate pressure. Self-cleaning wheel can handle dirty air without fouling.

- Sizes 27" – 80 ¾" wheel diameter
- Construction class 30
- Volume up to 375,000 CFM
- Pressure up to 40" WG
- Temperature range -30°F to 800°F
- Arrangements 1, 3, 7, 8, & 9

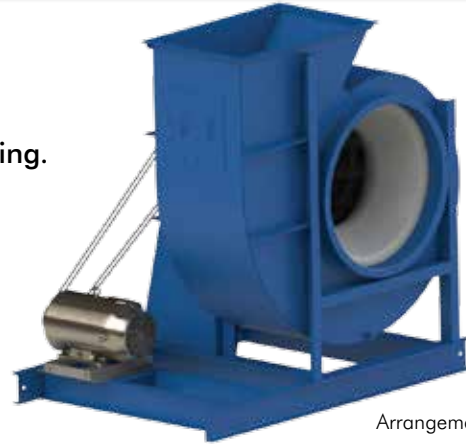

Arrangement 1 Shown

WHEEL TYPE RTS

Steel Wheel

- For clean to moderately dirty applications
- Tapered shroud
- Radially tip blades
- Operating temperatures up to 800°F
- Abrasion resistant materials available



RTS

- A. Continuously welded steel housing
- B. Fixed housing with any discharge angle
- C. All wheels are balanced to grade G6.3 or better
- D. Shafting is 1045 bearing grade TG&P
 - Sized for the first critical speed to be 1.25 times the max speed or higher
- E. Anti-friction pillow block bearings
 - Premium grease lubrication
 - Rated bearing life (L10) of 100,000 hours
- F. Inlet (flange style shown)
- G. Flanged outlet with mounting holes

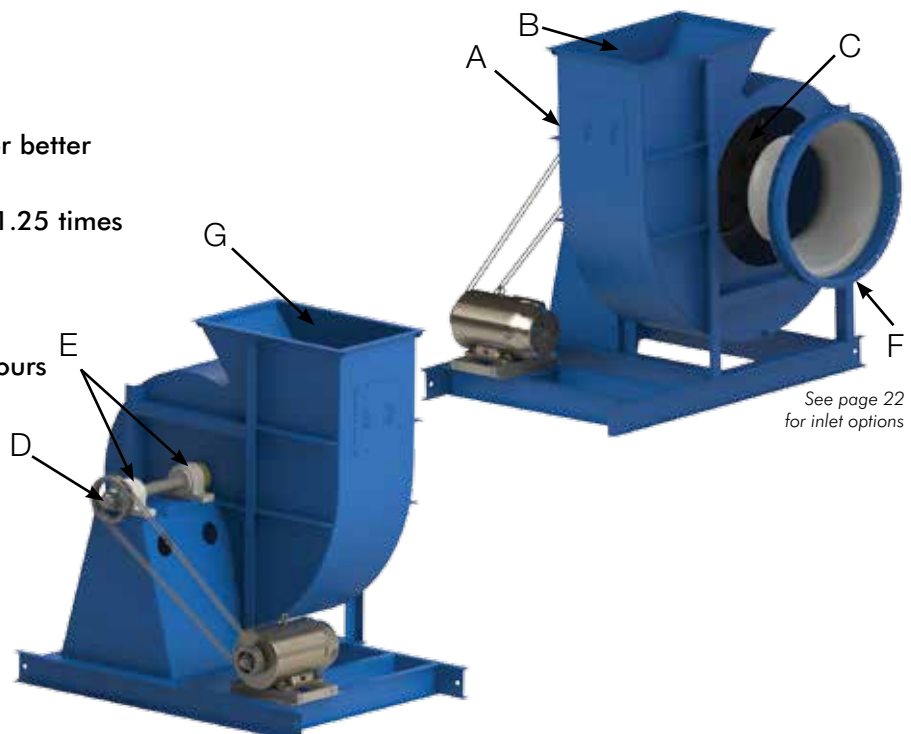

ADDITIONAL FEATURES

- Lifting lugs for use in installation
- Extended lubrication lines for easy maintenance
- Standard IATC blue enamel paint

CONSTRUCTION FEATURES

PB-PRESSURE BLOWERS

Shrouded optimized bladed design offers efficient and stable performance over a wide range of pressure and volume requirements. Inlet and outlet flanges are round for easy standard pipe duct connections. Suitable for a wide range of applications including combustion air, drying, conveying, cooling, and other process air systems.

- Sizes 14" - 26" wheel diameter
- Construction class 60
- Volume up to 10,250 CFM
- Pressure up to 66" WG
- Temperature range -30°F to 600°F
- Arrangements 1, 4, 4V, 8, 9, 10

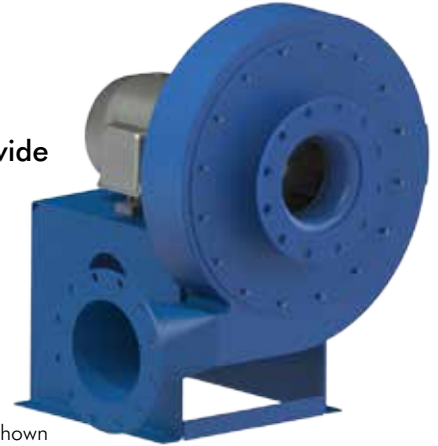

Arrangement 1 Shown

WHEEL TYPE PB

Aluminum Wheel

- For clean air applications at all volumes
- Tapered shrouds
- Radial blades (slightly backward inclined)
- Operating temperatures up to 200°F
- Riveted construction



Aluminum Wheel Construction

Steel Wheel

- For dust and light particulate applications
- Flat shrouds
- Radial blades
- Operating temperatures up to 600°F
- Welded construction

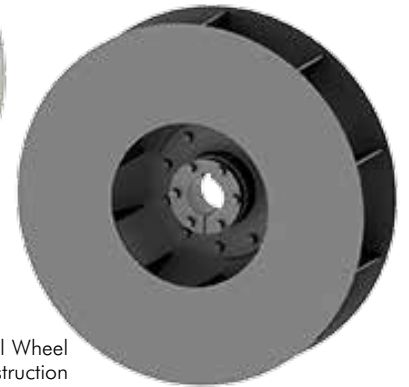

Steel Wheel Construction

PB

- A. Continuously welded steel housing
- B. Fixed housing with any discharge angle
- C. All wheels are balanced to grade G6.3 or better
- D. Shafting is 1045 bearing grade TG&P
 - Sized for the first critical speed to be 1.25 times the max speed or higher
- E. Anti-friction pillow block bearings
 - Premium grease lubrication
 - Rated bearing life (L10) of 40,000 hours
- F. Inlet (flange style shown)
- G. Flanged outlet with mounting holes
- H. Lifting lugs for use in installation

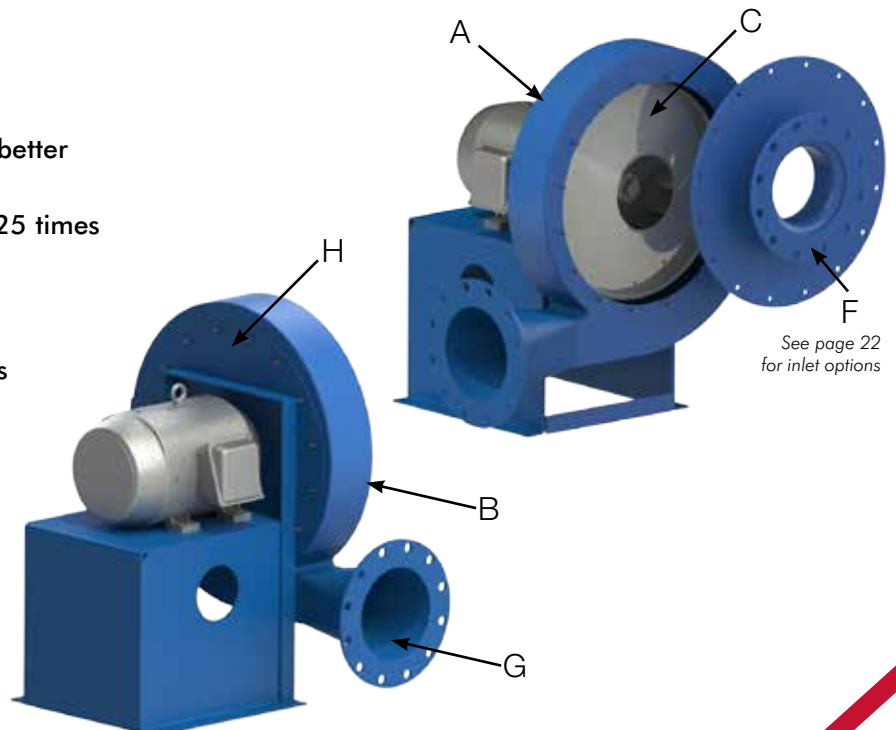

See page 22 for inlet options

ADDITIONAL FEATURES

- Extended lubrication lines for easy maintenance
- Standard IATC blue enamel paint

BCLS–BACKWARD CURVED LOWER VOLUME

Wheels are backwardly curved design for high efficiency, low noise used for low - medium and medium - high pressure applications where clean to lightly loaded air is present. Applications include primary air supply, product cooling, combustion air, drying, glass blowing and cooling, gas boosting, and pneumatic conveying.

- Sizes 27" – 73" wheel diameter
- Construction class 100
- Volume up to 95,000 CFM
- Pressure up to 80" WG
- Temperature range -30°F to 1000°F
- Arrangements 1, 4 & 8

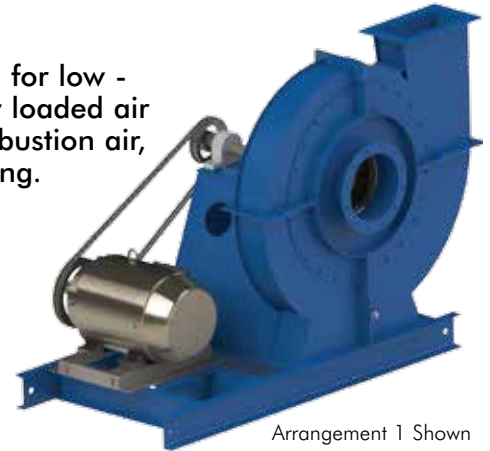

Arrangement 1 Shown

WHEEL TYPE BCLS

Steel Wheel

- For relatively clean air applications with little or no particulate
- Flat shroud
- Backward curved blades
- Operating temperatures up to 1000°F



BCLS

- A. Continuously welded steel housing
- B. Fixed housing with any discharge angle
- C. All wheels are balanced to grade G6.3 or better
- D. Shafting is 1045 bearing grade TG&P
 - Sized for the first critical speed to be 1.25 times the max speed or higher
- E. Anti-friction pillow block bearings
 - Premium grease lubrication
 - Rated bearing life (L10) of 100,000 hours
- F. Inlet (flange style shown)
- G. Flanged outlet with mounting holes

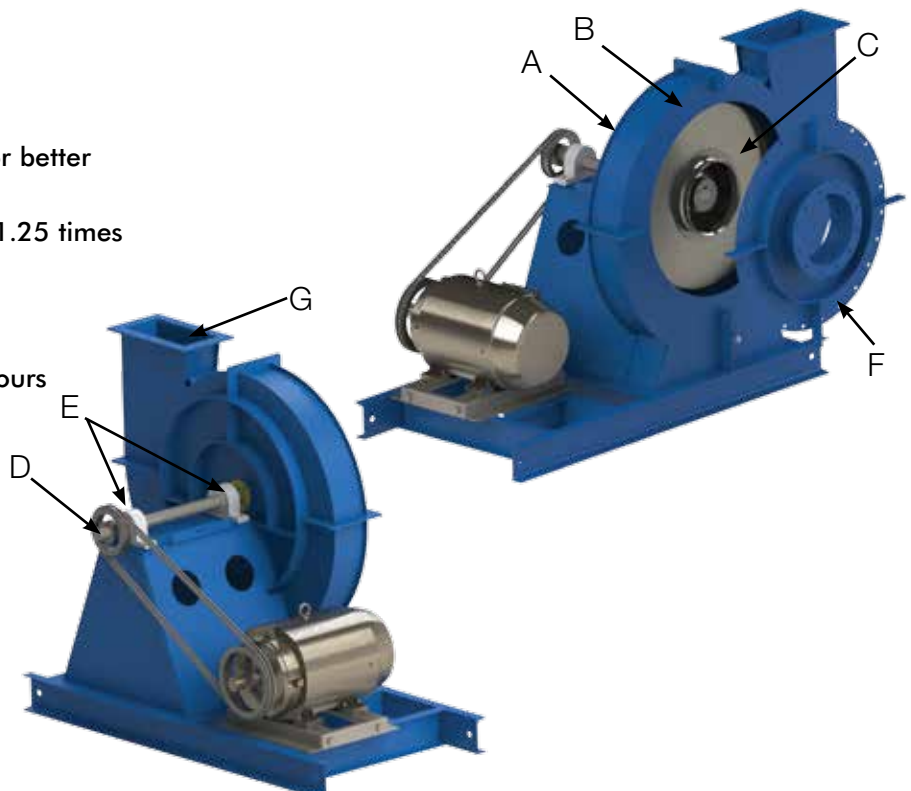

ADDITIONAL FEATURES

- Lifting lugs for use in installation
- Extended lubrication lines for easy maintenance
- Standard IATC blue enamel paint

CONSTRUCTION FEATURES

TROH-TURBO RADIAL OPEN HIGH

Radially bladed wheel design for very stable operation at relatively low volumes and high pressures. Suitable for high temperature and turndown applications. Extremely rugged, high pressure construction with round inlet and outlet connections, for easy standard pipe duct connections. Applications include combustion air, cooling, gas boosting, water stripping, fluid beds, glass blowing, textile fiber stripping, product drying, and pneumatic conveying.

- Sizes 20" – 58" wheel diameter
- Construction class 100
- Volume up to 34,000 CFM
- Pressure up to 80" WG
- Temperature range -30°F to 1000°F
- Arrangements 1, 4, 8 & 9

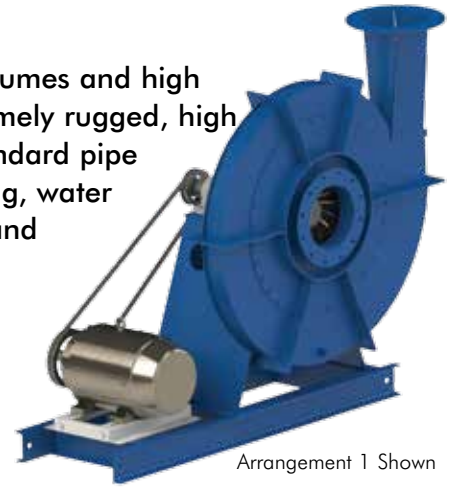

Arrangement 1 Shown

WHEEL TYPE TROH

Steel Wheel

- For relatively clean air applications with little or no particulate
- No shroud
- Radial blades
- Operating temperatures up to 1000°F



TROH

- A. Continuously welded steel housing
- B. Fixed housing with any discharge angle
- C. All wheels are balanced to grade G6.3 or better
- D. Shafting is 1045 bearing grade TG&P
 - Sized for the first critical speed to be 1.25 times the max speed or higher
- E. Anti-friction pillow block bearings
 - Premium grease lubrication
 - Rated bearing life (L10) of 100,000 hours
- F. Inlet (flange style shown)
- G. Flanged outlet with mounting holes

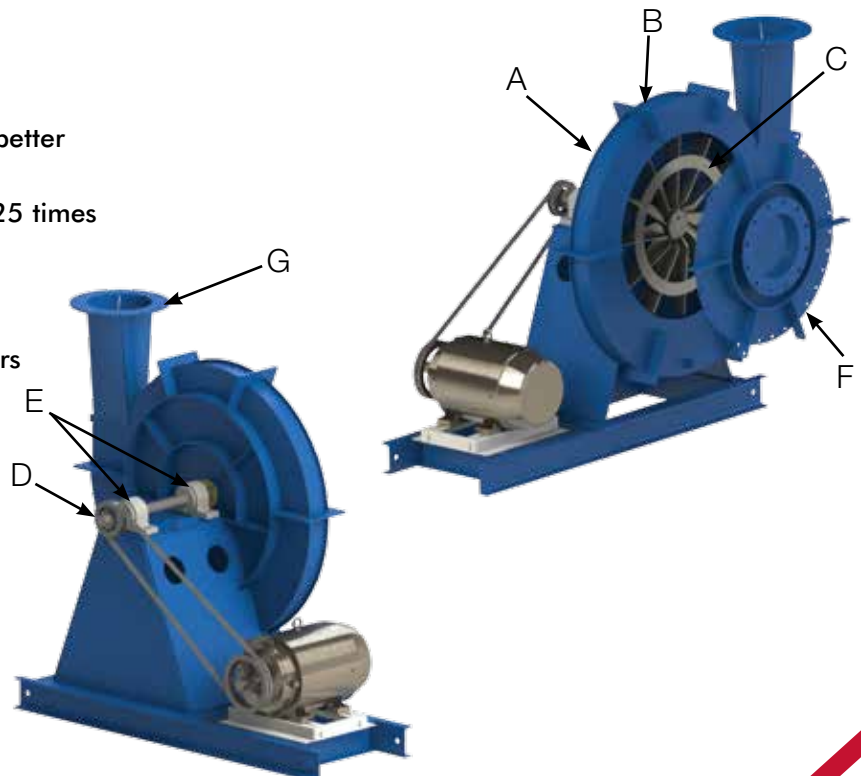

ADDITIONAL FEATURES

- Lifting lugs for use in installation
- Extended lubrication lines for easy maintenance
- Standard IATC blue enamel paint

TROL-TURBO RADIAL OPEN LOW

Radially bladed wheel design for very stable operation at low volumes and high pressures. Suitable for high temperature and turndown applications. Extremely rugged, high pressure construction with round inlet and outlet connections, for easy standard pipe duct connections. Applications include combustion air, cooling, gas boosting, water stripping, fluid beds, glass blowing, textile fiber stripping, product drying, and pneumatic conveying.

- Sizes 20" – 60" wheel diameter
- Construction class 100
- Volume up to 15,000 CFM
- Pressure up to 85" WG
- Temperature range -30°F to 1000°F
- Arrangements 1, 4, 8 & 9



WHEEL TYPE TROL

Steel Wheel

- For relatively clean air applications with little or no particulate
- No shroud
- Radial blades
- Operating temperatures up to 1000°F



TROL

- A. Continuously welded steel housing
- B. Fixed housing with any discharge angle
- C. All wheels are balanced to grade G6.3 or better
- D. Shafting is 1045 bearing grade TG&P
 - Sized for the first critical speed to be 1.25 times the max speed or higher
- E. Anti-friction pillow block bearings
 - Premium grease lubrication
 - Rated bearing life (L10) of 100,000 hours
- F. Inlet (flange style shown)
- G. Flanged outlet with mounting holes

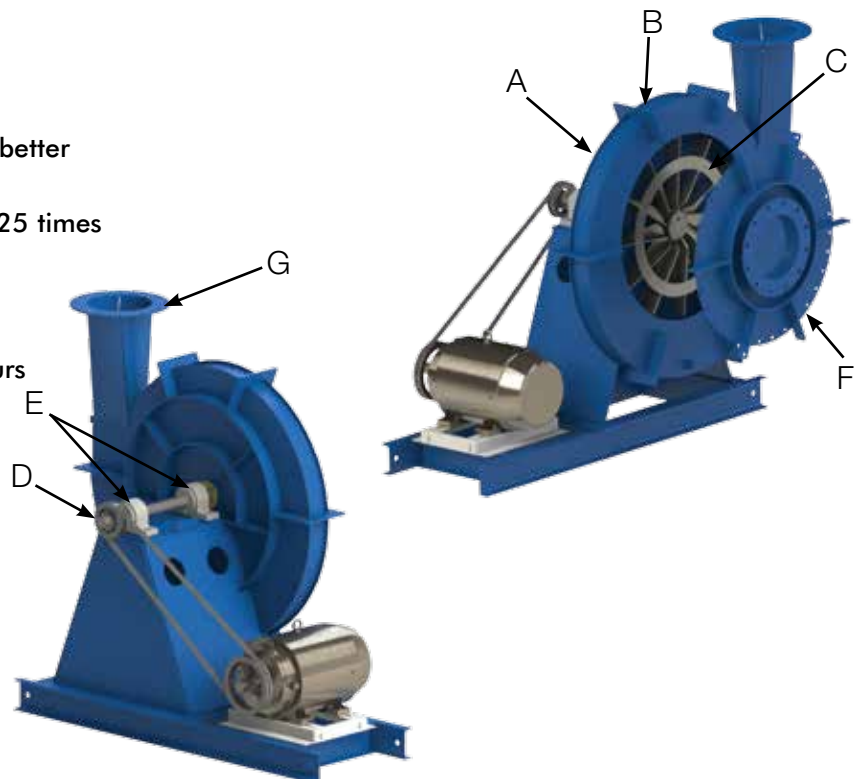

ADDITIONAL FEATURES

- Lifting lugs for use in installation
- Extended lubrication lines for easy maintenance
- Standard IATC blue enamel paint

ARRANGEMENTS

The term "Arrangement" is used to describe position of the motor relative to the fan. Main criteria which may influence your choice:

- Fan performance (temperature, contents of airstream, etc.)
- Size/location (footprint size of unit, access to various components on the fan, etc.)
- Drive method (belt or direct)

Belt Drive Pros:

- Allows fan to operate at "non-motor" speeds
- Easier to change fan speed & performance
- Motor positioning flexibility

Belt Drive Cons:

- Requires more maintenance
- Drive losses due to belt slippage
- May have horsepower limitations
- Belt noise

Direct Drive Pros:

- Usually more compact (size/footprint)
- Less components to maintain/balance
- No drive losses

Direct Drive Cons:

- VFD required to change speed or performance
- More expensive to change speed or performance
- Precise alignment of motor/coupling/shaft is critical
- Without a VFD, fan selection is limited to motor speed

Arrangement 1 – Belt Drive (overhung)

Overhung wheel on shaft and bearing assembly isolates fan bearings from the airstream. Motor mounts independently from fan, typically on a unitary base as shown.

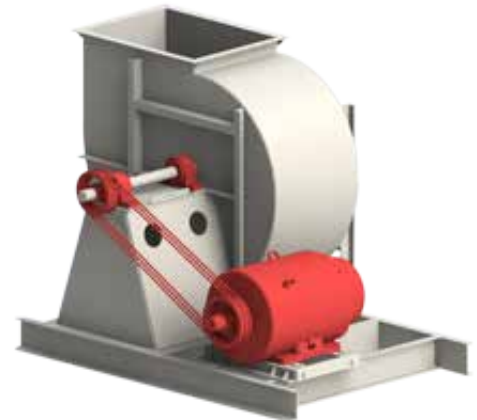

All guards and safety devices are not shown.

Arrangement 3 – Belt Drive (centerhung)

Wheel supported between bearings is compact and suitable for clean, dry-air service. This compact drive arrangement does not require a bearing pedestal. Suitable for ambient, clean air stream for either single or double inlet fans. Inlet boxes required for heated air streams.

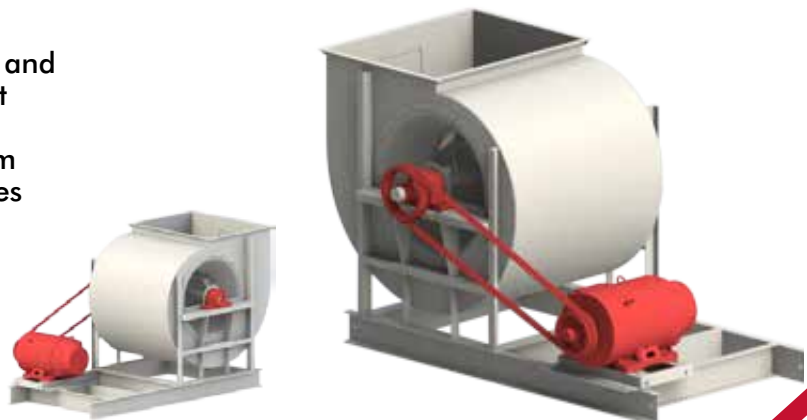

All guards and safety devices are not shown.

ARRANGEMENTS

Arrangement 4 – Direct Drive (overhung)

Wheel mounted directly on motor shaft to provide the most compact design. Elimination of shaft and bearings for minimum maintenance. Temperature restriction of 180°F due to close proximity of the motor to the housing.



All guards and safety devices are not shown.

Arrangement 4V – Direct Drive (vertical)

Wheel mounted directly on motor shaft to provide the most compact design. Elimination of shaft and bearings for minimum maintenance. Motor shaft is vertically oriented. Temperature restriction of 180°F due to close proximity of the motor to the housing.

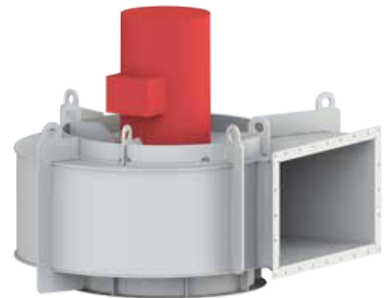

Arrangement 7 – Direct Drive (centerhung)

Wheel supported between bearings is compact and suitable for clean, dry-air service.

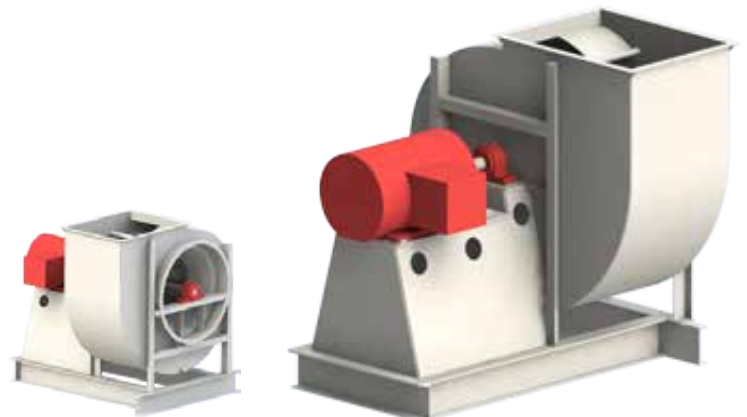

All guards and safety devices are not shown.

Arrangement 7 – Direct Drive (shown with optional inlet box) (center hung)

Wheel supported between bearings is compact and suitable for clean, dry-air service. An optional inlet box may be purchased to allow for bearings to be placed outside the airstream for dirty or high temperature air streams.

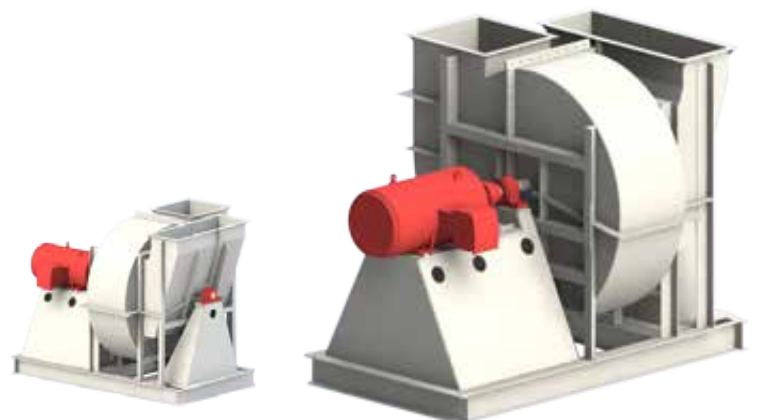

All guards and safety devices are not shown.

ARRANGEMENTS

Arrangement 8 – Direct Drive (overhung)
Integral pedestal furnished for the motor and coupling. Most flexible of the direct drive arrangements allowing for larger motors, fan sizes and accessories.

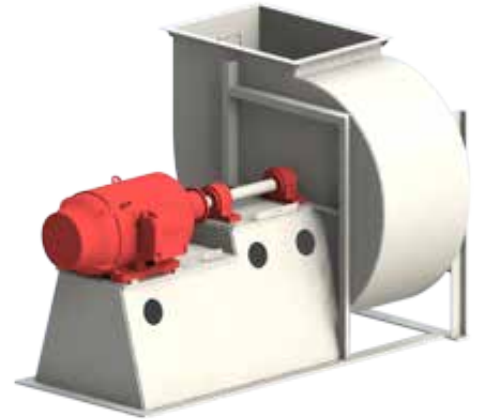

All guards and safety devices are not shown.

Arrangement 9 – Belt Drive (overhung)
An adjustable motor mount featured on this arrangement provides a compact grouping of motor, drive belt and fan. Similar to Arrangement 1, but with motor mounted on side of fan pedestal reducing overall size.



All guards and safety devices are not shown.

Arrangement 10 – Belt Drive (overhung)
Compact, packaged design with motor mounted within the fan pedestal.



All guards and safety devices are not shown.

AVAILABLE OPTIONS

- Access doors (hinged, bolted, flush, raised) with gaskets
- Safety guards (belt, shaft and coupling)
- Drain / plugs
- Custom paint - enamel, epoxy, hi-temp, zinc-rich, and powder coating
- High-temperature construction
- Stainless steel construction
- Abrasion resistant material construction
- Spark resistant construction – AMCA A, B, C

INLET CONFIGURATIONS

INLET TYPES FOR:

AFSW, BISW, BCHS, RTS, IRO, IRF, IRT, IRW, IRV fans.



Flanged with mounting holes



Slip collar

INLET TYPES FOR:

PB Blower



Flanged with mounting holes



PB slip collar inlet



PB venturi inlet

TYPICAL WEAR RESISTANT OPTIONS

Material in the airstream of a fan can cause wear and greatly diminish the service life of a fan. The first step is to choose the appropriate fan wheel type. After that, depending on the type of material being handled, size, volume, and abrasiveness, it is wise to consider upgrading the primary wear surfaces of the air stream to combat the detrimental effects of wear.

Adding abrasion resistant options to your material handling fan can enhance the service life of your fan. Shown below are some of the options available that will provide enhanced wear resistance to the fan wheel and housing of the fan. Generally, there are two basic ways to incorporate more abrasion resistant materials. One is to make the components from abrasion resistant materials that are structurally sound. The other is to use abrasion resistant materials as liners. Refer to the image below as a reference, then please contact one of our Customer Service Representatives to discuss your application and what options are available to extend your fan service life.

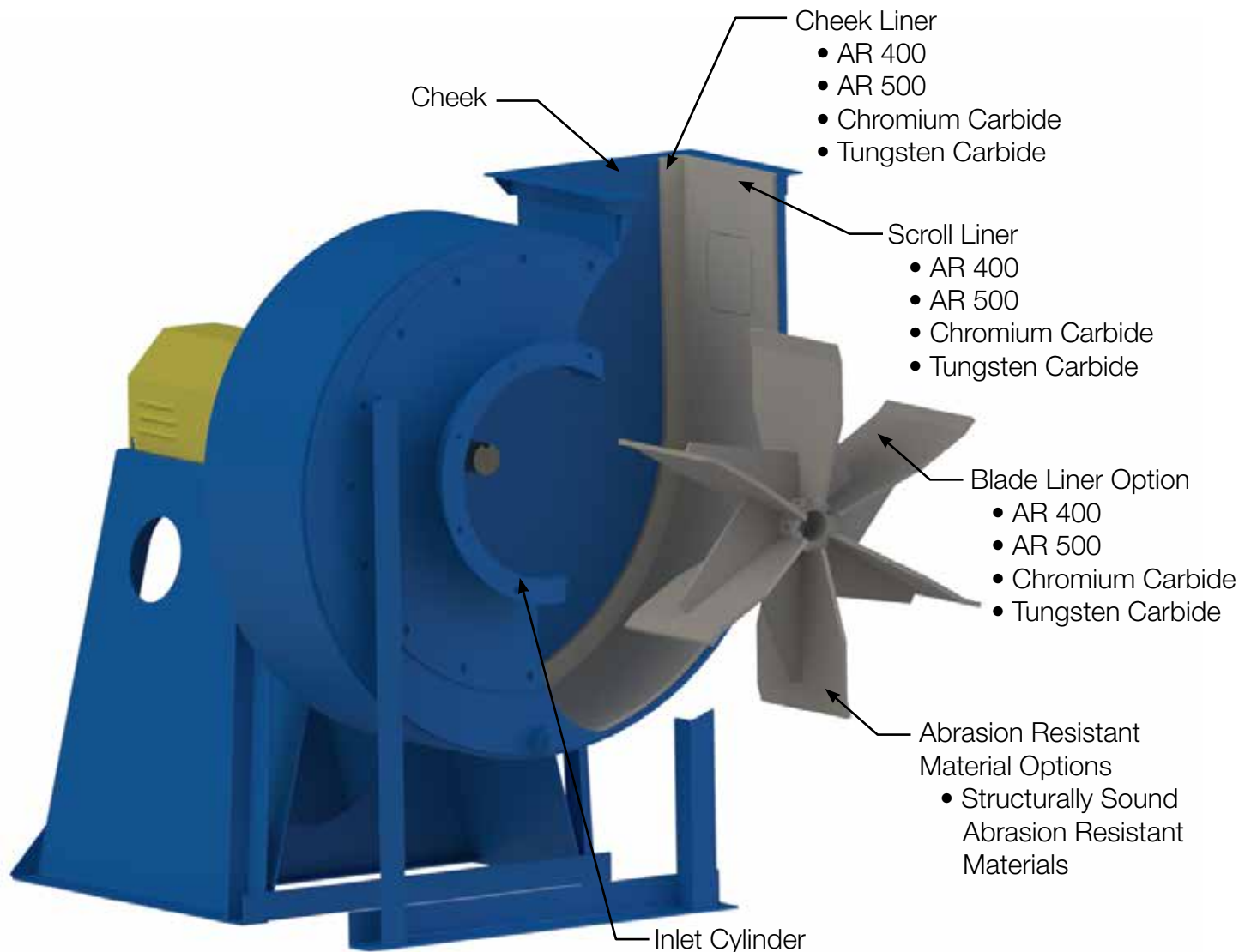

DAMPERS

Industrial Dampers

IATC industrial dampers are used to control the flow of air through Centrifugal Industrial Fans. Dampers can be attached directly to fans, inlet boxes, or ducts. Many factors should be considered when choosing the appropriate damper for your application, such as airstream conditions, purpose and limits of airflow control, budget and even non-damper options such as VFD control. Additionally, each mounting position has its own operating characteristics which should be understood for a well-designed system and can effect fan selection.

All damper models are available in corrosion resistant stainless steel construction, aluminum, abrasion resistant material, or high temperature heat resistant alloys. Standard dampers can be modified to suit system design requirements not mentioned here. IATC is experienced at damper fabrication and can also build custom dampers to your design.

Inlet dampers

Dampers are often installed on the fan inlet as energy saving devices when the airflow needs to be modulated or run for extended periods of time at reduced flow. They are also effective for reducing the fan load at start-up or conditions with varying air densities.

Parallel Blade

Parallel blade type inlet box dampers may be used to control the airflow through the system. The airfoil shaped blades are parallel to the fan shaft and remain parallel to each other as the damper is closed. Thus, in a partially closed position, a forced vortex with the same rotational direction as the fan impeller will be generated within the inlet box. The effect on the fan characteristics will be similar to that of a variable inlet vane control.



Variable Inlet Vane (VIV) Dampers

Variable inlet vane dampers (also called vortex dampers) are mounted on the fan inlet to conserve fan horsepower at reduced airflow conditions. They are arranged to generate an inlet vortex (pre-rotation) in the same direction as the fan impeller, causing a reduction in power, consumption as the air flow is reduced. This type of control is most effective when the fan is expected to operate at reduced performance conditions for extended time periods or if the system requires modulation during operation. It will alter the fan operating characteristics and reduce the likelihood of instability. A wide-open VIV will produce a system effect which must be accounted for in the original fan selection.

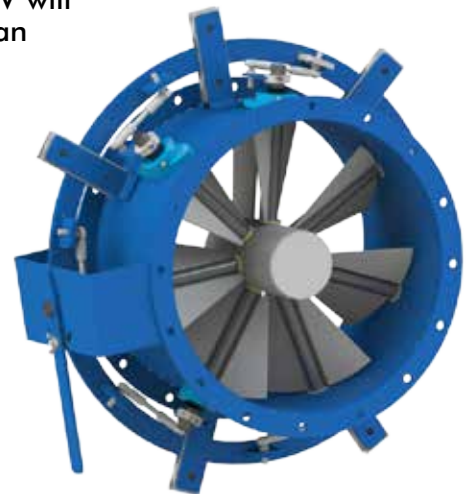

ADDITIONAL OPTIONS

- Aluminum construction
- Stainless steel construction
- High temperature construction
- Abrasion resistant construction
- AMCA spark A, B, C construction
- Pneumatic and electric actuators

DAMPERS

Outlet Dampers

Outlet dampers, also called volume control dampers, are basic elements which create a variable resistance within a system. If it is desirable to compensate for temporary air density or system resistance changes, an outlet damper may be appropriate. They are the least expensive, but also the least efficient of the traditional flow control devices. Because outlet dampers operate as a resistance in the system, they do not change the operating characteristics of the fan, but merely restrict its flow. Flow restrictions can cause Centrifugal Industrial Fan operation to become unstable and outlet damper use must be considered carefully. Due to efficiency and stability concerns, an outlet damper should not typically be used as a permanent flow restriction. IATC provides dampers for both ductwork and fan applications.

Opposed Blade Damper

Opposed blade dampers are built such that adjacent blades rotate in the opposite, or opposed, direction. This style of operation is the best selection for an outlet damper because it offers good control over the entire operating range and maintains an even distribution of air downstream from the damper. The blades are airfoil shaped to minimize the flow restriction of the damper in the open position. Commonly used for cold starting on many air and process gas systems, opposed blade dampers maintain even air distribution downstream of the damper.



Butterfly Dampers

Although butterfly dampers are normally associated with ductwork, there are applications in which they have been successfully used on the fan outlet. Generally, the damper would be wide open during normal operating conditions and closed only occasionally, such as at start-up. The fan typically would have a smaller outlet area, and produce a relatively low volume of airflow. IATC provides butterfly dampers for both ductwork and fan applications.



ADDITIONAL OPTIONS

- Aluminum construction
- Stainless steel construction
- High temperature construction
- Abrasion resistant construction
- AMCA spark A, B, C construction
- Pneumatic and electric actuators

ACCESSORIES

Accessories

Industrial Air Technology offers a full line of accessory products. All accessory offerings are available in a variety of materials including stainless steel, zinc plating and abrasion resistant materials.

Screens

The purpose of screens is to restrict larger objects or debris from entering the air stream, while still allowing air to flow. Screens are available in any size for both inlets and outlets of fan, dampers, and silencers.

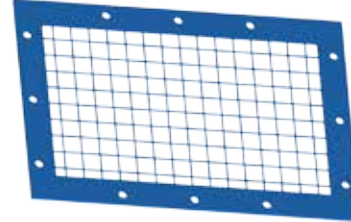

Inlet Boxes

IATC inlet boxes are designed to fit in tight footprints and direct air uniformly into fan inlets. Similar to our fans, IATC inlet boxes are designed for reliable performance, have predicted pressure drops for efficient fan operation and available with many options including access doors, drains, split housing, paint coatings and materials of construction. In combination with parallel dampers are an excellent choice for airflow control.



Silencers

Used to reduce the noise output (DBA) of a fan. A silencer affects only noise resulting from air turbulence within the fan. It does not affect noise radiated through the fan housing, mechanical noise produced by the motor and drive, or noise produced by vibration. Silencers are available for both inlets and outlets of fans.

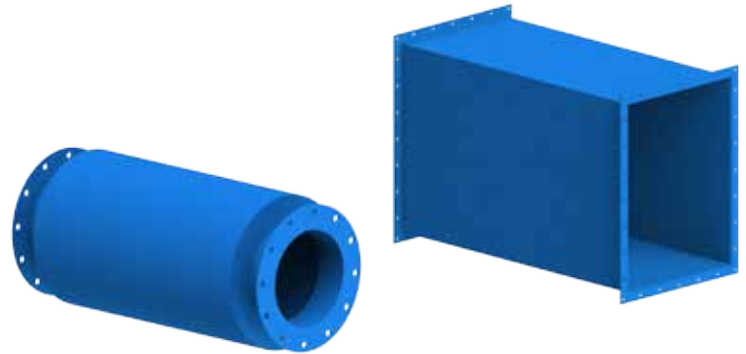

Weather Hoods

Covers fan or duct inlets or outlets to impede the entrance of rain or snow into the air stream.

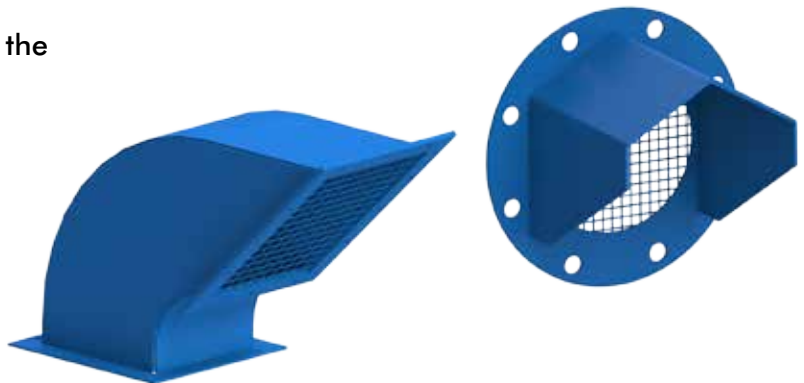

ACCESSORIES

Flexible Connectors

Used to isolate loads and vibration transmission on inlets and outlets, while also allowing for minor misalignment of connections. Flex material comes in a variety of compounds. For negative pressure applications, dirty airstreams or higher velocity flow rates, flex connectors often require internal deflectors to protect fabric. Flanges are constructed from carbon steel, zinc plated carbon steel, or stainless steel.

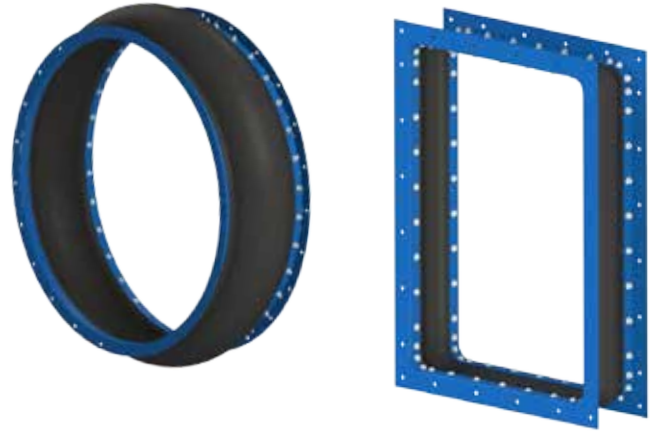

Inlet Transitions

Transitions connect fan inlets to inlet duct and other components. They are typically used when the inlet size is different than the duct or other component being attached to the fan inlet. Available in round to round or round to square configurations.

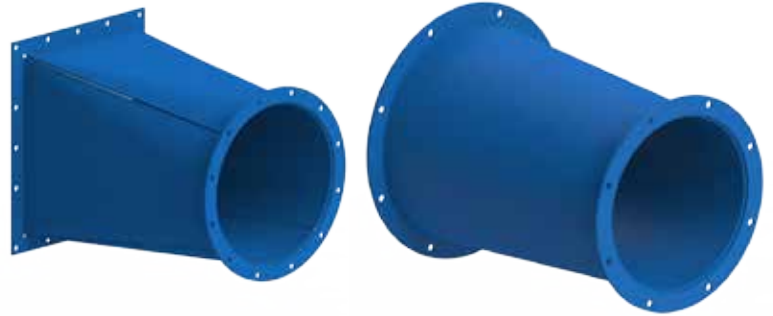

Outlet Transitions

Transitions connect fan outlets to outlet ducts and other components. They are typically used when the outlet size is different than the duct or other component being attached to the fan outlet. Available in rectangle to round, rectangle to square, round to round, and round to square configurations.

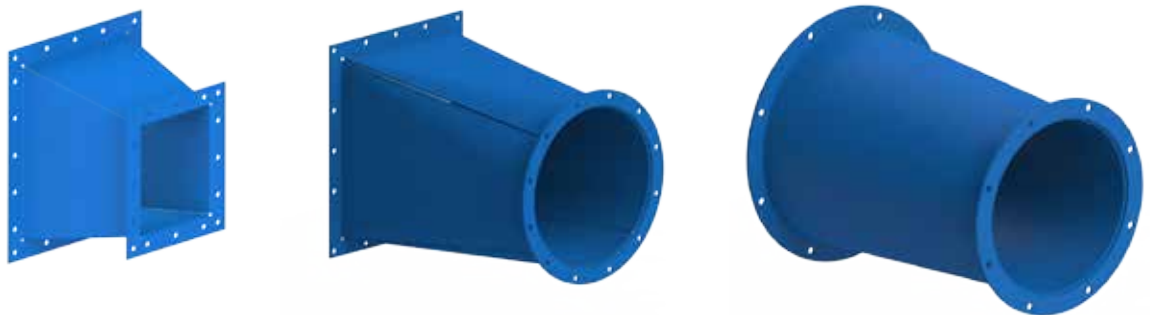

Fan Bases

Provides common mounting platform for fan, motor, and inlet boxes.

- Unitary Base – Rigid mount C-channel construction ready to install to foundation.
- Inertia Base – Sturdy construction frame with rebar ready for on-site installation of concrete to provide vibration dampening.



ACCESSORIES

Sensors

IATC offers a variety of sensors to help meet your preventative maintenance requirements. We can supply temperature and vibration sensors that can then be integrated into your monitoring controls to help keep your fans running trouble free.

- **Speed Sensors** - IATC offers Zero-Speed switches when installed will alert end users if fan quits rotating and for simple rpm history.
 - **Temperature Sensors** - Installed on bearings we offer a variety of RTD's, thermistors or thermocouples based on your preferences.
 - **Vibration Sensors** - IATC offers accelerometers that can be installed on individual bearings or simply located between bearings.
-

Vibration Isolators

Isolator mounts are used to isolate and reduce transient vibrations generated by floor-mounted mechanical equipment located in non-critical areas.

Housed Spring - High deflection, color-coded springs with built in restraints to resist lateral forces without restraining vertical movement. Telescoping housing with ribbed isolation pad assists with noise reduction, as well. Slots or holes are provided for adjustment.

Rubber in Shear (RIS) - Suitable for low load vibration. Narrow width and height rubber mounts provide excellent damping qualities and sound absorption. RIS isolators are easy to install in small spaces and do not require adjustment.

Insulation

Thermal Insulation

Thermal insulation is added in cases where the temperature of the air being transferred or stored is impacted by the temperature of the ambient air. Some systems are insulated to maintain process temperatures for both cold and hot systems, to provide burn protection, and energy savings.

Acoustical Insulation

Acoustical insulation is added for noise reduction or sound attenuation.

Industrial *Air* Technology Corp.

P.O. Box 2317, Gaylord, MI 49734
Customer Service: 989-731-5840
Phone: 989-705-1768 • Fax: 989-732-1641
www.indairtech.com