

XSeries technical data and dimensions

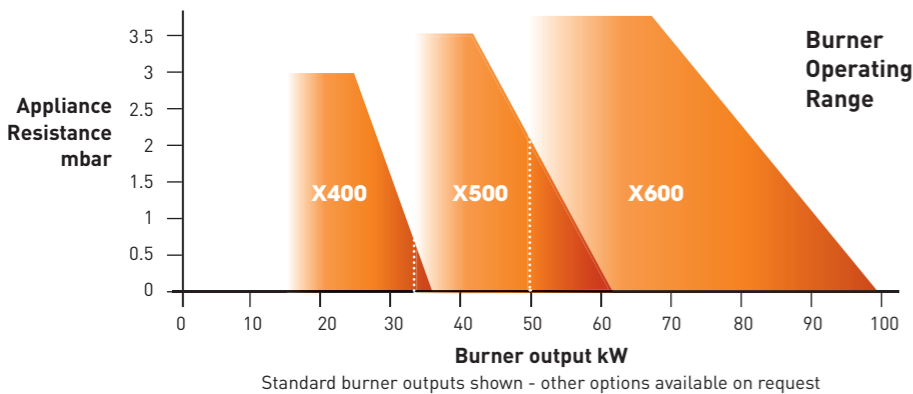
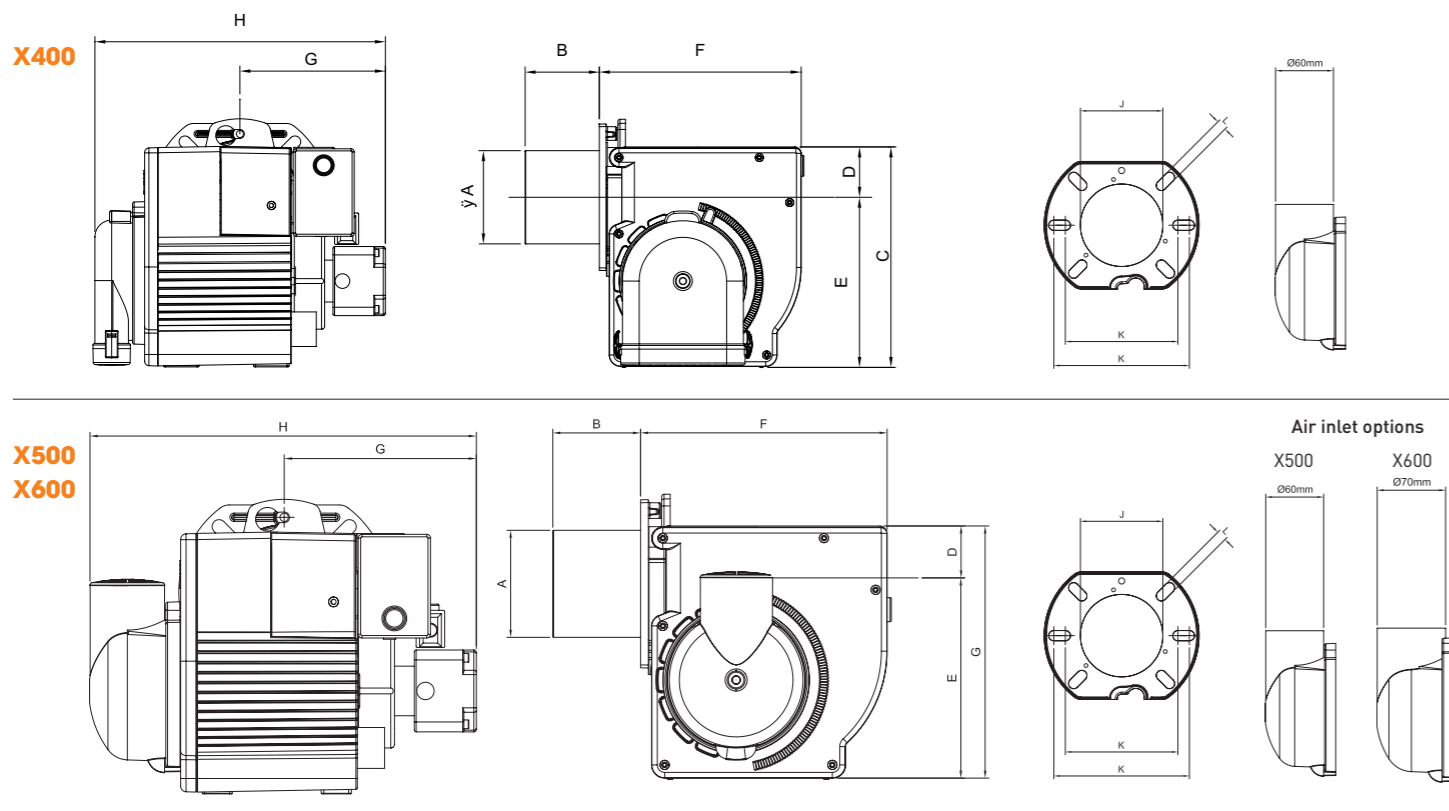

Technical training
EOGB offers a wide range of accredited training courses covering gas, oil and dual fuel burners and related subjects.

Burners for commercial and industrial heating
EOGB is the sole UK distributor of Baltur oil, gas and dual-fuel burners which offer outputs from 14kW to 40MW – ask for details or visit our website.

Burner dimensions (mm)

	AØ root	AØ max	B*	C	D	E	F	G	H	JØ	KØ	L
X400	89	89	80	231	50	161	194	138	297	90	125-150	10
X500	89	89	80	231	50	161	204	159	318	90	125-150	10
X600	89	89	140	231	50	161	204	169	360	90	125-150	10

*Guidance only – other tube lengths are available



EOGB Energy Products Ltd, 5 Howard Road, Eaton Socon, St Neots, Cambridgeshire PE19 8ET

Tel: 01480 477 066 Fax: 01480 477 022 Email: sales@eogb.co.uk www.eogb.co.uk



X SERIES BURNERS

Reliable energy

from **EOGB**



14kW to 100kW burners

INNOVATIVE FEATURES | ADVANCED DESIGN | UK MANUFACTURED | ENHANCED RELIABILITY



XSeries burners for domestic and light commercial heating

X400 X500 X600

EOGB's XSeries range of oil burners delivers excellence in performance and reliability, backed by first-class technical expertise and a personable, responsive service.

Designed for the UK

The XSeries is built for the UK where there are significant differences in the oil fired burner market from other countries and the predominant use of kerosene, coupled with modern boiler designs, places extra demands on the burner.

The Xseries range features:

- Superior performance
- Sophisticated construction
- Advanced design
- Easy maintenance

Built for today's markets

From concept to production, every aspect of the XSeries has been rigorously tested.

Attention to detail ensures reliable, continuous operation and compatibility with high resistance oil-fired boilers. Powerful motors with high temperature bearings are standard to give extra life and reliability and internationally recognised quality procedures are followed to monitor the highest standards of manufacture and performance.



Contact us today

to discuss your burner requirements. Full technical product data is available on our website at www.eogb.co.uk.

XSERIES BURNER RANGE

Three sizes from 14kW to 100kW

X400	14 - 36 kW
X500	34 - 62 kW
X600	50 - 100 kW



Effort free installation and maintenance

The compact XSeries burner fits most existing boilers and a universal mounting flange provides a solid airtight attachment, secured by a single screw. There is excellent access to all components without the need to break oil or electrical connections.

For added convenience, adjustment points for oil pressure, air and control box are all front-facing and the whole control pack can be easily released. The XSeries offers simplicity and convenience which reduces installation and maintenance costs.

Meets stringent European environmental requirements

The XSeries has been designed to meet EN267 and exceeds current European Standards for emissions.

At EOGB the highest priority is given to developing environmentally safe products and as part of this philosophy, the simple adjustment facilities of the XSeries encourage optimisation of performance for safe and economic operation.

Supporting now, developing for the future

All EOGB personnel are long-serving members of the oil firing industry with extensive knowledge of oil firing technology, supplying high quality products and services through boiler makers and specialist distributors in the UK and Ireland.

To meet new applications and changing requirements, EOGB operates a continuous development policy to satisfy future demands.

- The XSeries is suitable for Bio-Diesel applications up to B10. Burners for higher blends e.g B30 are also available
- Extensive range of oil, gas and dual fuel burners from 14-4500kW ex stock
- Fast and reliable spares service
- Technical and training support
- Designed and built in the UK using industry standard components

