

SPD/P

Pulversan Infestation Destroyer

Machine for the mechanical disinfection of floury products from insects and their eggs to be inserted in the pneumatic transport circuit.

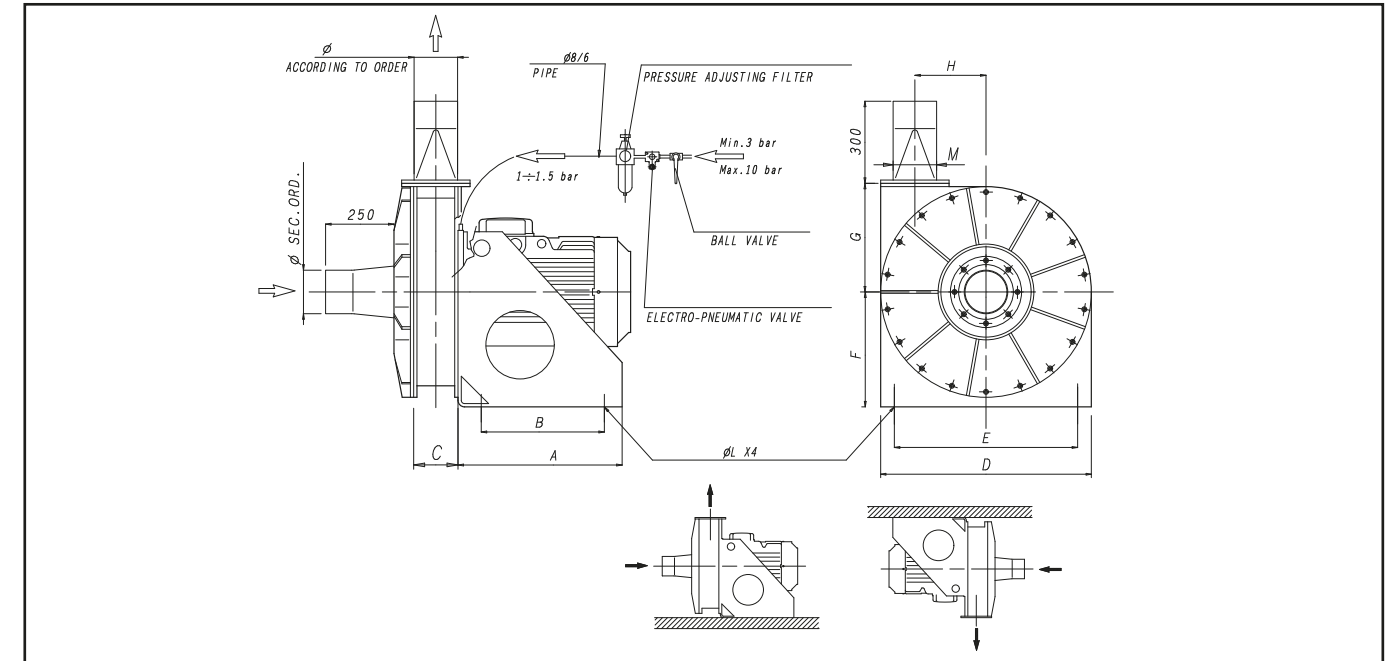

Model	KW	Capacity (flour) t/h 50 Hz - 3000 RPM	A	B	C	D	E	F	G	H	øL	M	Weight
SPD 45/ 5.5-P	5.5	2											355
SPD 45/7.5-P	7.5	3.5	300	210	100	600	520	330	308	197	14	140	380
SPD 45/11-P	11	5.5											405

Model	KW	Capacity (flour) t/h 50 Hz - 3000 RPM	A	B	C	D	E	F	G	H	øL	M	Weight
SPD 50/18.5-P	18.5	8											485
SPD 50/22-P	22	10			162								495
SPD 50/30-P	30	12	600	450		770	670	420	397	260	18	150	510
SPD 50/37-P	37	15			633								
SPD 50/45-P	45	20			695								
SPD 50/55-P	55	22			280								723

Units = mm