

# TRF

## Turbo Sifter

Machine particularly suitable for flour redressing before bagging. It is used as a cleaning waste selector.

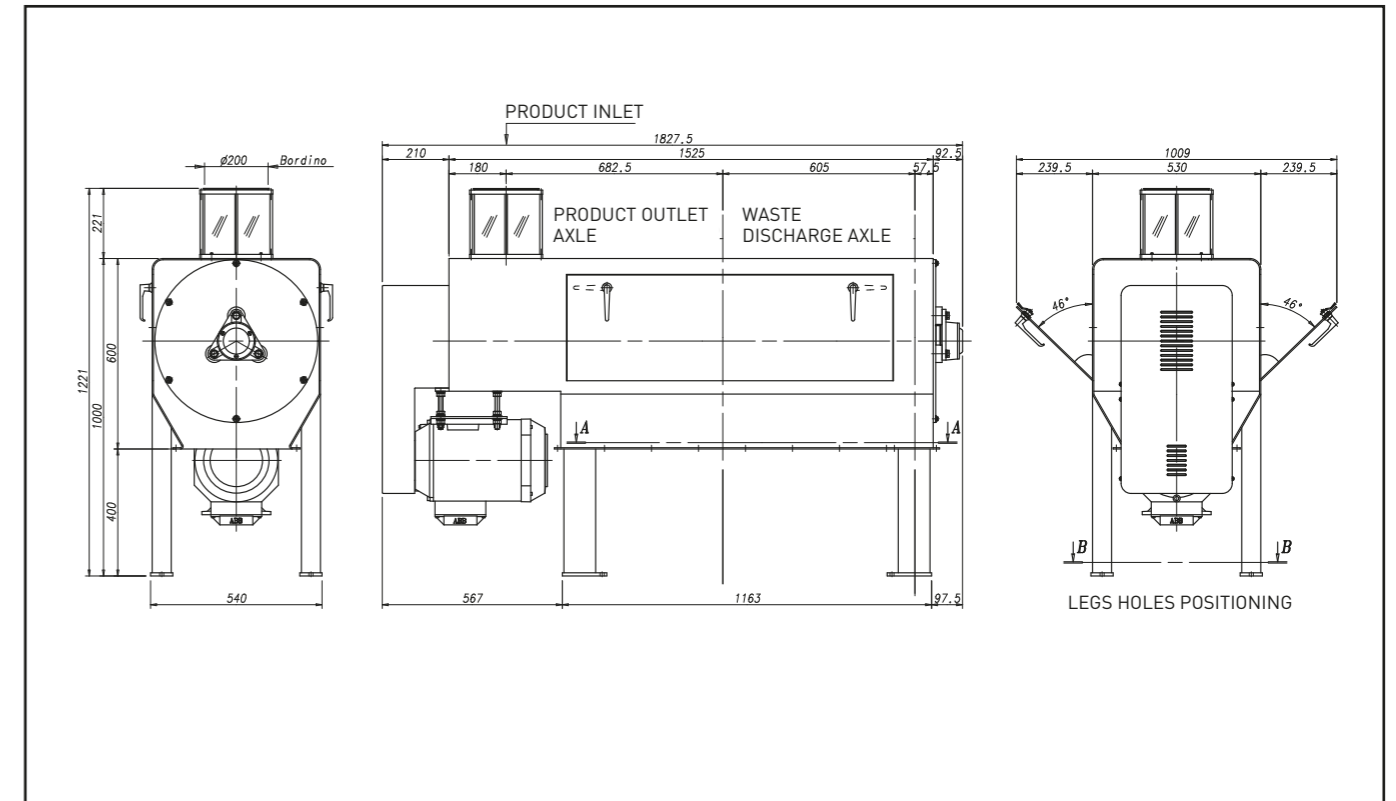
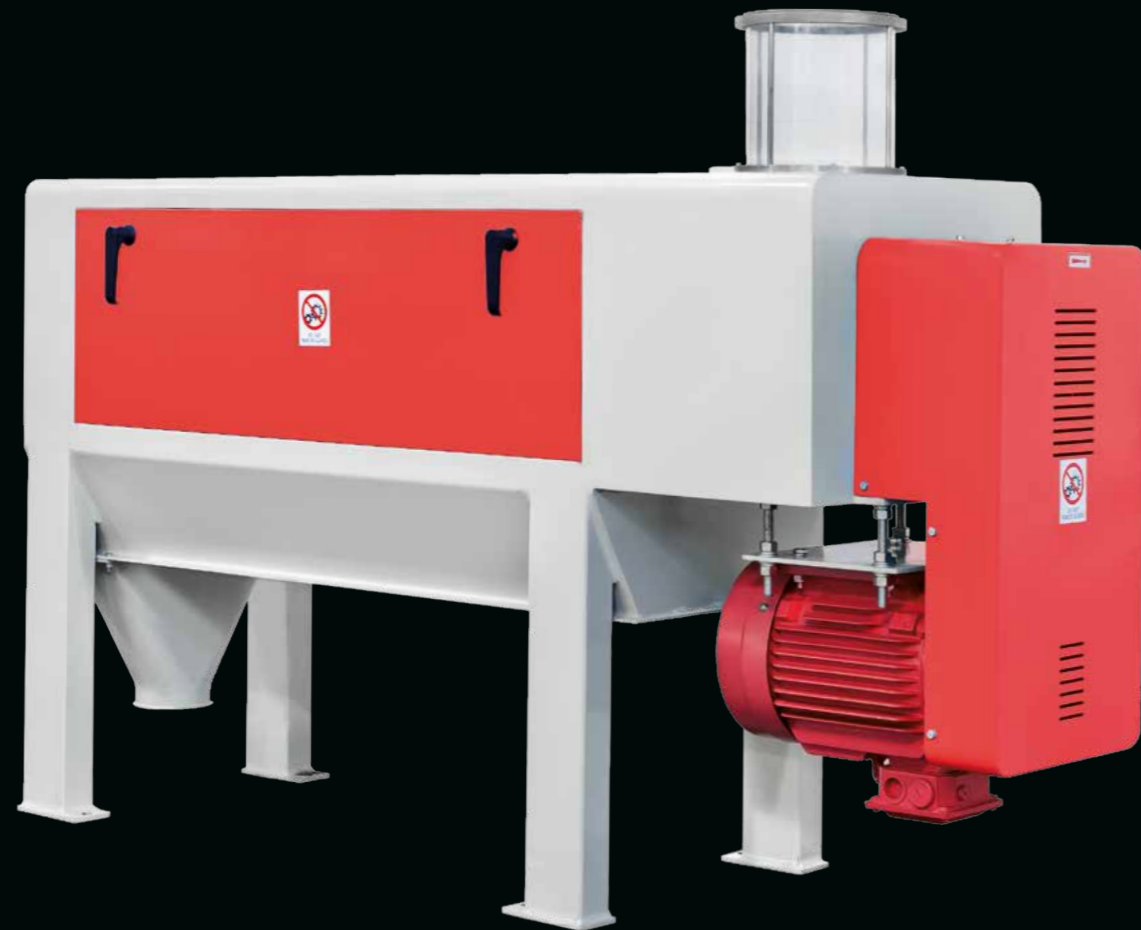

| Type             | Machine passage     | Screen                 | Capacity<br>t/h | kW  | Weight<br>Kg |
|------------------|---------------------|------------------------|-----------------|-----|--------------|
| TFR 40/100 - 5,5 | Screenings cleaning | Metal sheet holes d. 3 | 20              | 5,5 | 318          |
| TFR 40/100 - 7,5 | Flour redressing    | Metal sheet holes d. 3 | 40              | 7,5 | 325          |

Units = mm