

Glassmax Giraffe [320kg x 4.8m]

The Glassmax Giraffe is a multifunctional hoist perfect for overhead or vertical glazing.

With the ability to handle loads of up to 320kg to a height of 4.8m (up to 5.4m when the lifter is in a horizontal position), the Glassmax Giraffe features 90° hydraulic tilt and 360° manual rotation for manipulation of glass into optimum position.

Key Features

- Capacity: 320kg
- Dual circuit vacuum system with reserve tank, non-return valve and vacuum gauge for each circuit
- Suitable for vertical & horizontal glazing
- Easily transportable and quick to assemble
- Counterweight system
- 90° hydraulic tilt from manual pump
- 360° manual rotation

Reference Code

MCO01

Technical Specifications

Capacity	320kg
Max horizontal lifting height	5.4m
Max vertical lifting height	4.8m
Width	900mm
Length	2350mm
Weight (exc. counterweights)	390kg
Weight (inc. counterweights)	590kg

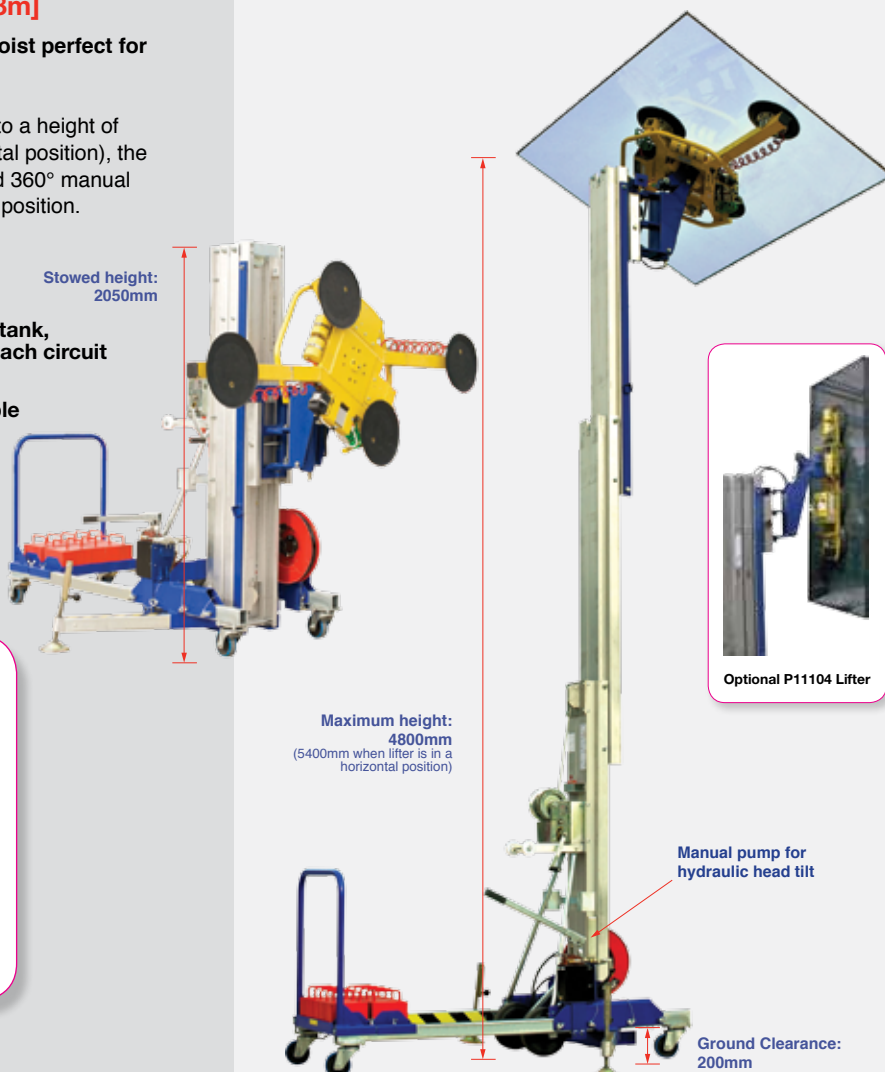

Technical Data (mm)

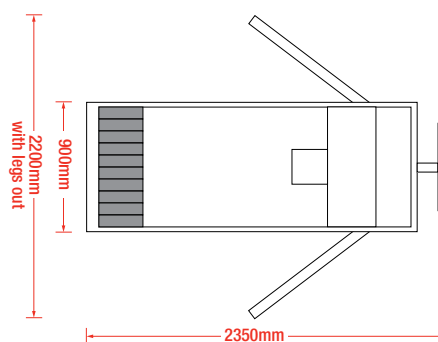

Note: Weights must be secured before lifting