

## Glassmax 250 [250kg x 7.5m]

The lightweight manual Glassmax hoist can be combined with a GGR vacuum lifter for quick and effective installation of vertical glazing.

The Glassmax hoist can handle loads of up to 250kg to a hook height of 7.5 metres. The Glassmax is simple to build and dismantle, with removable counterweights, making it easy to transport to site.

An optional fork attachment can be used for the installation of HVAC units, pipes, ducts and palletised loads.

### Technical Specifications

<b>Capacity</b>	250kg
<b>Max. hook height</b>	7.5m
<b>Width</b>	800mm
<b>Length</b>	2130mm
<b>Weight (exc. counterweights)</b>	230kg
<b>Weight (inc. counterweights)</b>	330kg

### Key Features

- Capacity: 250kg
- Multi-functional lightweight manual hoist
- Easily assembles and disassembles for transport by van
- Counterweight system
- Ideal for vertical glazing when combined with a vacuum lifter
- Optional 240v powered winch available
- Vacuum lifter sold/hired separately

### Reference Code

**MCO07**



### Technical Data (mm)

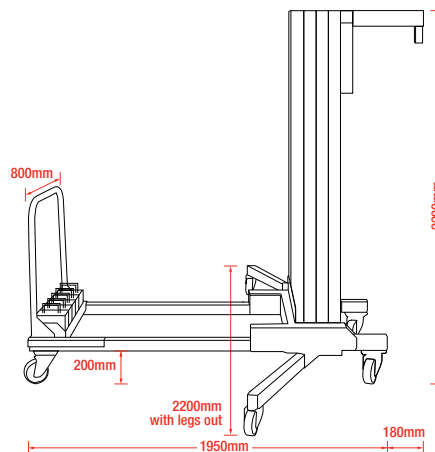

Note: Weights must be secured before lifting



## Glassmax 500 [500kg x 4.8m]

The robust Glassmax 500 hoist can lift 500kg to 4.8m and is easy to assemble and disassemble with a removable counterweight system.

This multi-functional manual hoist is perfect for overhead or vertical glazing when combined with one of our vacuum lifters.

An optional fork attachment can be used for the installation of HVAC units, pipes, ducts and palletised loads.

### Technical Specifications

Capacity	500kg
Max. hook height	4.8m
Width	800mm
Length	2150mm
Weight (exc. counterweights)	270kg
Weight (inc. counterweights)	470kg

### Key Features

- Capacity: 500kg
- Multi-functional lightweight manual hoist
- Easily assembles and disassembles for transport by van
- Counterweight system
- Ideal for vertical glazing when combined with a vacuum lifter
- Vacuum lifter sold/hired separately

### Reference Code

MCO09



### Technical Data (mm)

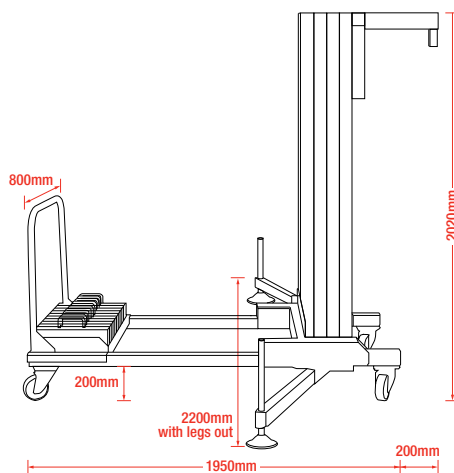

Note: Weights must be secured before lifting



Optional Fork Attachment  
560mm (w) x 700mm (l)