

Technical Specification Sheet

Gamma Levator (VSL65)

[500kg]

This multi-purpose vacuum lifter makes light work of lifting dense porous stone, steel and composite materials.

Encompassing 500kg of lifting power, the Gamma Levator is a versatile below-the-hook vacuum lifter that comes with a range of multi-configurable frames to suit varying load shapes and sizes:-

Gamma G1 - Standard vacuum lifter with 200kg capacity. Dimensions 270mm (w) x 430mm (h) x 460mm (l)

Gamma G2 - With two 460x275mm suction pads and adjustable length from 320mm to 770mm. 500kg capacity.

Gamma G4 - With four 275x160mm suction pads, adjustable length from 320-1200mm and adjustable width from 320-770mm, ideal for lifting large format materials. 200kg capacity.

Gamma G5 - with two 400x90mm elongated suction pads ideal for kerb stones. 150kg capacity.

Features

- 150kg - 500kg capacity dependent on frame configuration
- Powered by 12V battery with 240v charger
- Constant running vacuum circuit with low vacuum alert
- Weight of gamma levator (solo device): 42kg
- Weight of gamma levator (with 500kg capacity pad): 52kg
- 8 hours battery life
- Ref: VSL65

G2 Suction Frame Option

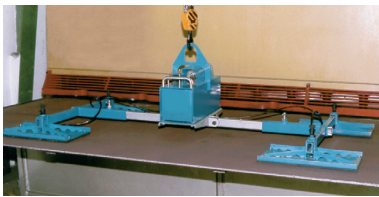

G4 Suction Frame Option



G5 Suction Frame Option



Dimensions

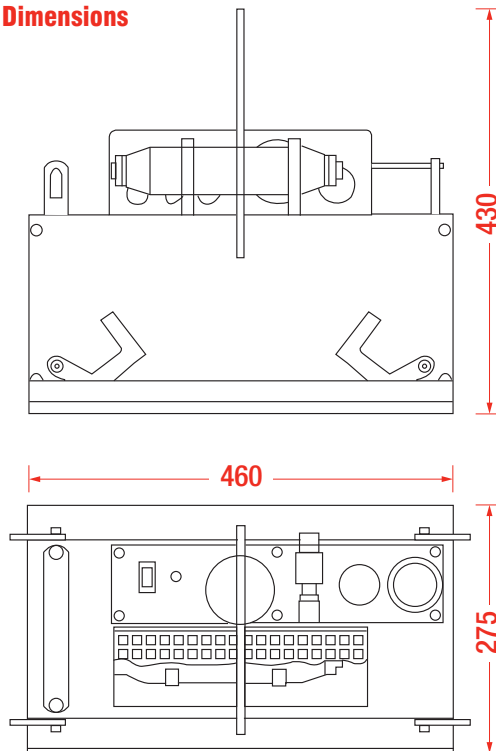

HIRE OR PURCHASE TODAY - CALL OUR SPECIALIST TEAM ON:

North: +44 (0)161 683 2580 - South: +44 (0)1844 202 071 - Scotland: +44 (0)1698 824444