

Technical Specification Sheet

Multi-Glaze (VGL120)

[400kg]

The Multi-Glaze is the ideal choice for safely installing vertical and horizontal textured glass panels of up to 400kg capacity (depending on number of pads used).

With a width of 940mm and a length of 1700mm, it is powered by two 12v on-board rechargeable batteries with external charger.

This dual circuit lifter also comes with 90° tilt and an audio-visual low vacuum warning. Using this machine to lift textured glass and loads with uneven surfaces is subject to testing by GGR Group.



Technical Specifications

Safe working load	capacity:	400kg*
Number of suction cups	cups:	8 or 12
Suction cup	description:	closed cell foam seal. Round pads Ø 250mm. Oval pads 100x320mm
Suitable for lifting	materials:	stippled, etched, frosted and other textured glass. Other materials possible, subject to testing.
Weight of lifter	approx:	130kg
Tilt	tilt:	90° manual
Vacuum system	dual circuit:	2 pumps, 2 vacuum reserve tanks
Voltage	pump:	2 x 12v (24v) DC from rechargeable batteries
	battery charger:	110v/240v external charger system
Standard accessories	standard:	green "safe to lift" light, external charger
Optional accessories	optional:	cable remote control, radio remote control

* depending on type and number of pads

Key Features

- Capacity: 400kg
- Dual circuit vacuum system
- 90° tilt function
- On-board vacuum and battery charge meters
- Low vacuum warning
- Not suitable for use in the rain
- Not suitable for thin or fragile glass
- Ref: VGL120

Technical Data (approx. mm)

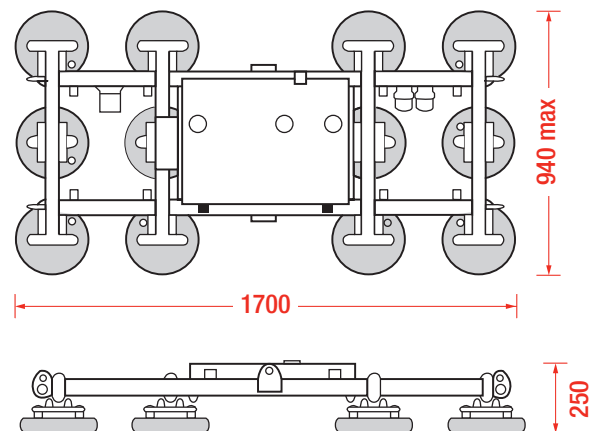

HIRE OR PURCHASE TODAY - CALL OUR SPECIALIST TEAM ON:

North: +44 (0)161 683 2580 - South: +44 (0)1844 202 071 - Scotland: +44 (0)1698 824 444