

Boasting Two Tonnes O

Hydraulica 2000 [2000kg]

One of the most powerful vacuum lifters in the industry, the Hydraulica 2000 comes with a huge 2000kg capacity for lifting heavy-duty glass, metal, plastics and more.

Boasting 210° powered rotation alongside powered hydraulic tilt from vertical to horizontal, the Hydraulica 2000 gives operators ultimate control when lifting heavy loads.

Perfect for lifting large format glass and non-porous plate materials, the Hydraulica 2000 has four to six individual vacuum pumps and low vacuum alert system for added safety. Cable remote control is included for operation of vacuum suction and release, as well as hydraulic tilt.

Key Features

- Capacity: 2000kg
- Dual circuit vacuum system with four to six on-board maintenance free pumps
- Powered hydraulic 90° tilt from vertical to horizontal
- Powered hydraulic 210° rotation
- 12v rechargeable battery with integral 110v or 240v charger and battery energy gauge
- Audio-visual low vacuum warning
- Cable remote control as standard
- Wheeled stand for transport and storage available
- Individual pads can be isolated for irregular units (reduces safe working load)



Technical Specifications

Safe working load (smooth, clean surface at 60% vacuum)	capacity:	2000kg*	1050kg
Number of suction cups	cups:	26	14
Suction cup	description:	black rubber, not abrasion resistant, heat resistant up to 100°F	
Suction cup diameter	diameter:	330mm	
Suitable for lifting	material properties:	gastight / non-porous	
	surface:	smooth	
	example:	glass, plastic boards, ceramic plates, sheet metals, coated boards	
Weight of lifter	approx:	500kg	360kg
Depth of lifter	depth:	380mm	
Rotation	rotation:	105° left & right powered hydraulic	
Tilt	tilt:	90° powered hydraulic	
Vacuum system	dual circuit:	4 to 6 pumps, 2 vacuum reserve tanks	
Voltage	pump:	12v DC from rechargeable battery	
	battery charger:	110v/240v 50/60Hz single phase factory selectable	
Standard accessories	standard:	cable remote control, extension arms with pads (increasing the capacity from 1050kg to 2000kg)	
Optional accessories	optional:	wheeled stand, radio remote control (2000-B only)	

* The capacity is 2000kg with extension arms and 26 pads fitted.

Hydraulica 2000-A



Cable remote control as standard



Reference Code

VGL57A

Technical Data - Hydraulica 2000-A (mm)

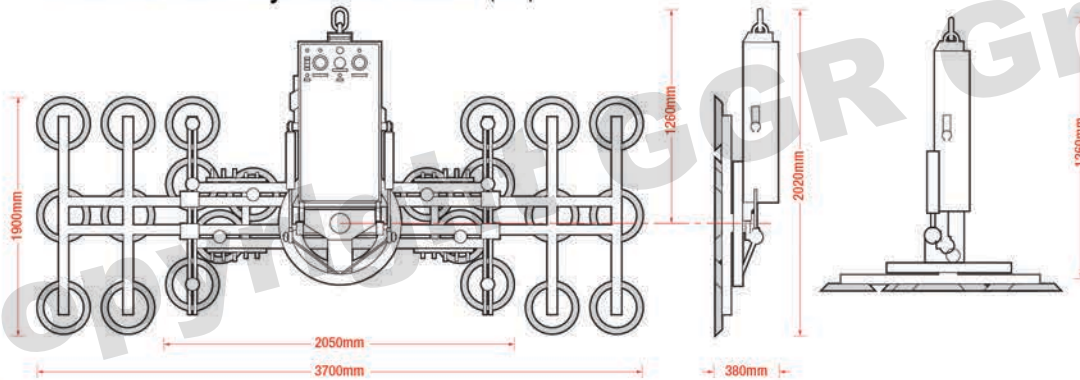

Hydraulica 2000-B

Reference Code

VGL57

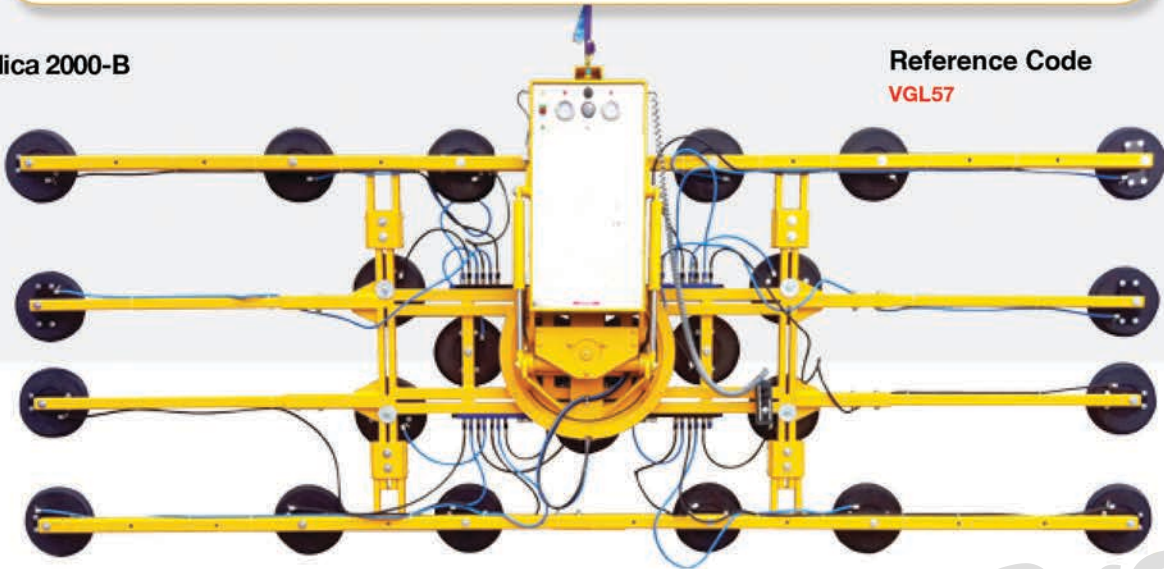

Technical Data - Hydraulica 2000-B (mm)

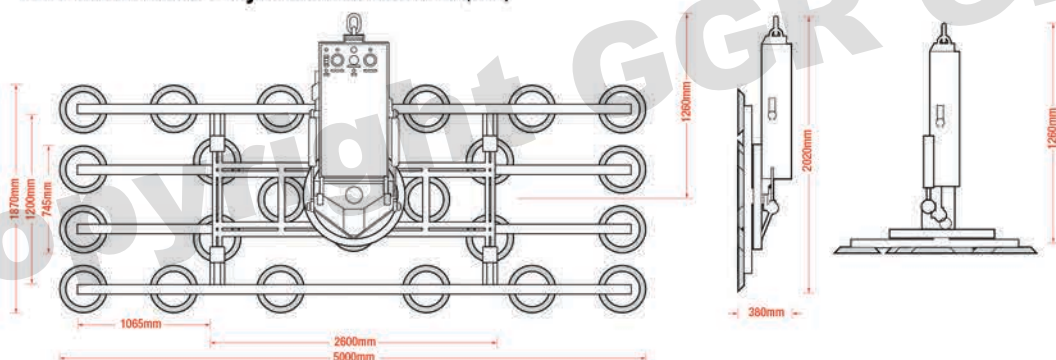

Optional radio remote