

Powerful Quad-Circuit

Kombi 7441-Quadra [1125kg]

The Kombi 7441-Quadra glass lifter is a safe pair of hands for moving heavy and unusually shaped glass loads as it uses **four independent vacuum circuits** and a multi-configurable frame to lift up to 1125kg.

A maximum of twelve suction pads and four arm extensions can be added to this versatile lifter, with the ability to isolate each pad. The Kombi 7441-Quadra also offers a stepless 90° hydraulic powered tilt function and manual 100° left and right rotation for easy handling and installation of glazed units with an optional radio remote control.

Key Features

- Capacity: 1125kg (dependant on configuration)
- Four circuit vacuum system with reserve tank, non-return valve and vacuum gauge for each circuit
- Powered hydraulic 90° tilt from horizontal to vertical
- Manual 100° left & right lockable rotation
- 12v rechargeable battery with external 110/240v charger
- Quick change battery system (spare battery)
- Audio-visual low vacuum warning
- Cable remote as standard, optional radio remote
- Individual pads can be isolated to accommodate irregular shapes (reduces safe working load)

Reference Code

VGL59

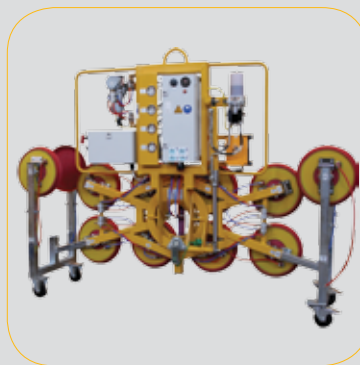
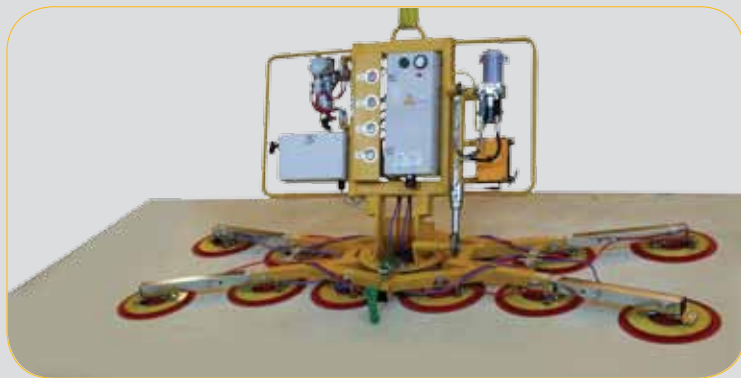

Optional Kombi wheeled trolley



Four independent vacuum circuits

Technical Specifications

Safe working load (smooth, clean surface at 60% vacuum)	capacity:	1125kg	750kg	500kg
Number of suction cups	cups:	12	8	6
Suction cup	description:	red rubber, not abrasion resistant, heat resistant up to 100°F		
Suction cup diameter	diameter:	350mm		
Suitable for lifting	material properties:	gastight / non-porous		
	surface:	smooth		
	example:	glass, plastic boards, ceramic plates, sheet metals, coated boards		
Weight of lifter	approx:	157kg (with 12 pads)		
Depth of lifter	depth:	300mm		
Rotation	rotation:	100° manual left & right		
Tilt	tilt:	90° powered hydraulic		
Vacuum system	quad circuit:	1 pump, 4 vacuum reserve tanks		
Voltage	pump:	12v DC from rechargeable battery		
	battery charger:	110v/240v 50/60Hz single phase factory selectable (external)		
Standard accessories	standard:	cable remote control, four extension arms		
Optional accessories	optional:	radio remote control, wheeled trolley		

350mm diameter pads.



Optional radio remote



Cable remote control as standard

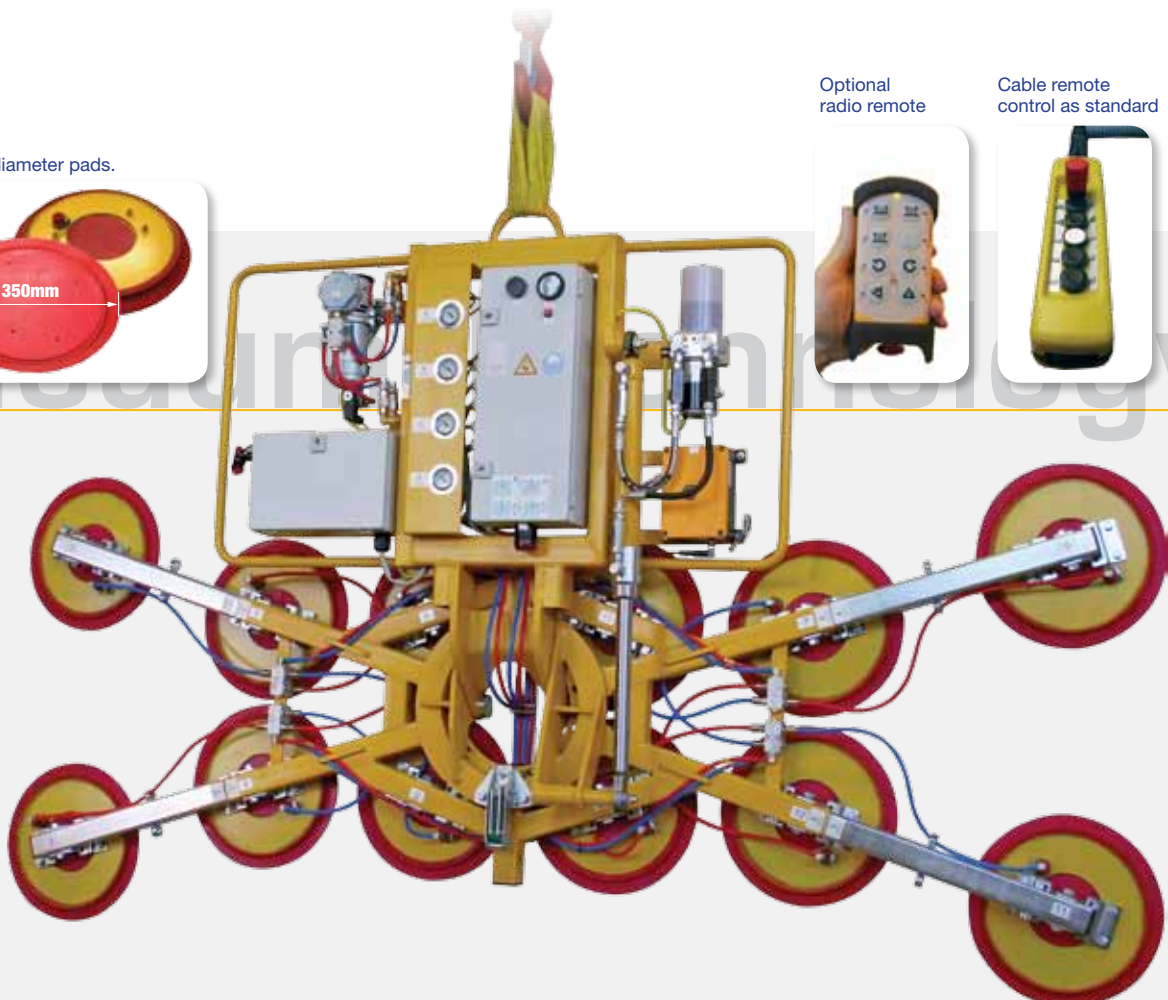

Technical Data (mm)

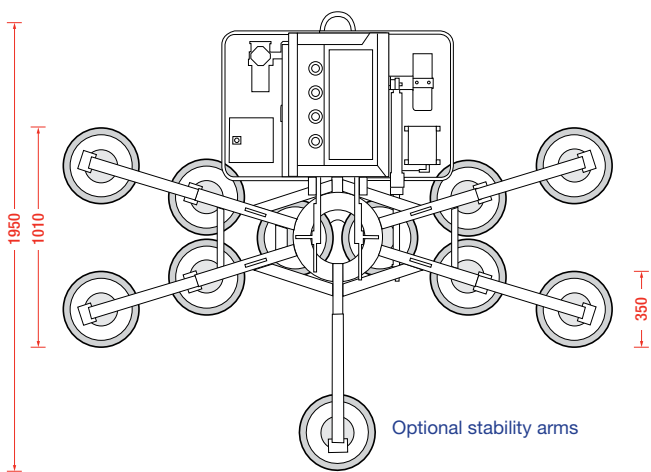
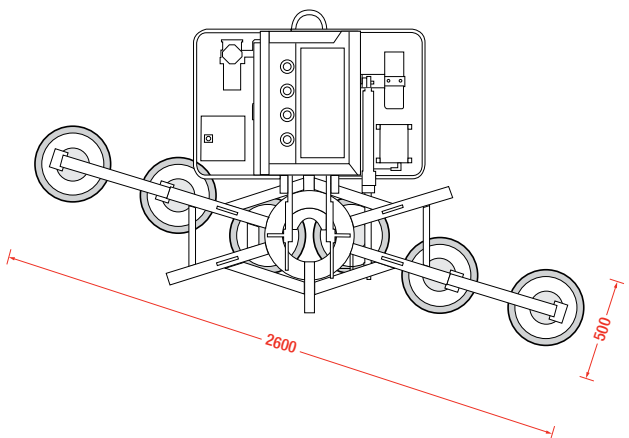
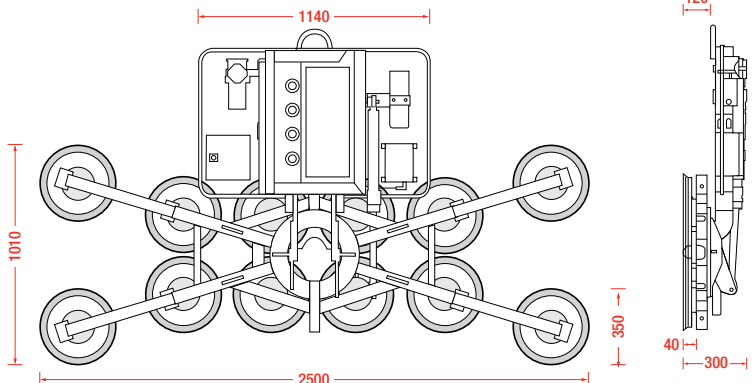
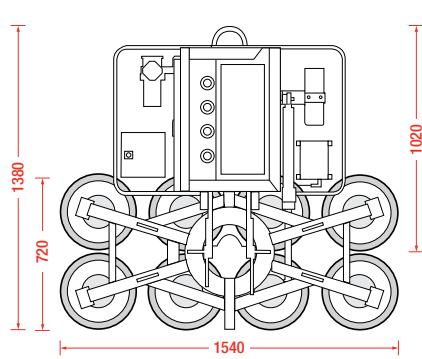

Optional stability arms