

# Glass Vacuum Lifters

## Slender & Powerful Lift

### DSZ2-L 900 Slimline [900kg]

One of our slimmest lifters at 180mm, the DSZ2-L fits in the gap between the building scaffold and envelope. The DSZ2-L is fully featured with manual 360° continuous rotation & 90° hydraulically dampened tilt.

The dual circuit DSZ2-L includes six extension arms and pads as standard to raise the maximum capacity from 450kg to 900kg. The lifter can also be supplied with an optional wheeled stand for easy storage and transport.

#### Key Features

- Capacity: 900kg
- Dual circuit vacuum system with reserve tank, non-return valve and vacuum gauge for each circuit
- Hydraulically dampened 90° tilting from vertical to horizontal
- Manual 360° lockable rotation (continuous)
- Two or four integral maintenance-free vacuum pumps
- 2 x 12v rechargeable batteries with integral 110v or 240v charger and battery energy gauge
- Audio-visual low vacuum warning
- Six extension arms with pads supplied as standard
- Optional wheeled stand
- On-board control panel

#### Reference Codes

Hydraulically Dampened Tilt - **VGL39**

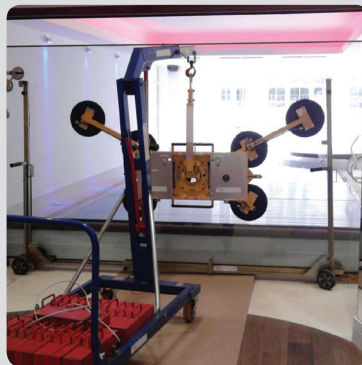
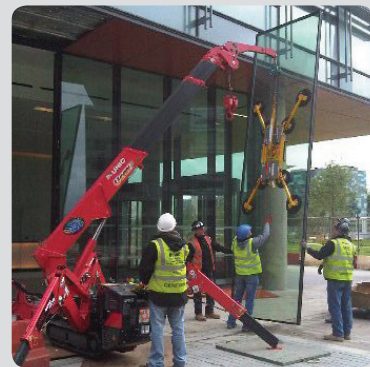

#### Technical Specifications

<b>Safe working load</b> (smooth, clean surface at 60% vacuum)	capacity:	900kg*	750kg**	450kg
<b>Number of suction cups</b>	cups:	12	10	6
<b>Suction cup</b>	description:	black rubber, not abrasion resistant, heat resistant up to 100°F		
<b>Suction cup diameter</b>	diameter:	330mm		
<b>Suitable for lifting</b>	material properties: surface: example:	gastight / non-porous smooth glass, plastic boards, ceramic plates, sheet metals, coated boards		
<b>Weight of lifter</b>	approx:	140kg (with arms)	125kg (with arms)	105kg (without arms)
<b>Depth of lifter</b>	depth:	180mm		
<b>Rotation</b>	rotation:	360° manual lockable		
<b>Tilt</b>	tilt:	90° hydraulically dampened as standard		
<b>Vacuum system</b>	dual circuit:	2 or 4 pumps, 2 vacuum reserve tanks		
<b>Voltage</b>	pump: battery charger:	12v DC from x 2 rechargeable batteries 110v/240v 50/60Hz single phase factory selectable		
<b>Standard accessories</b>	standard:	4x extension arms with pads, adjustable lift bail		
<b>Optional accessories</b>	optional:	cable remote control, wheeled stand, radio remote control, low marking pads		

\* The capacity is only 900kg with 6 extension arms and 12 pads fitted. \*\* The capacity is only 750kg with 4 extension arms and 10 pads fitted.

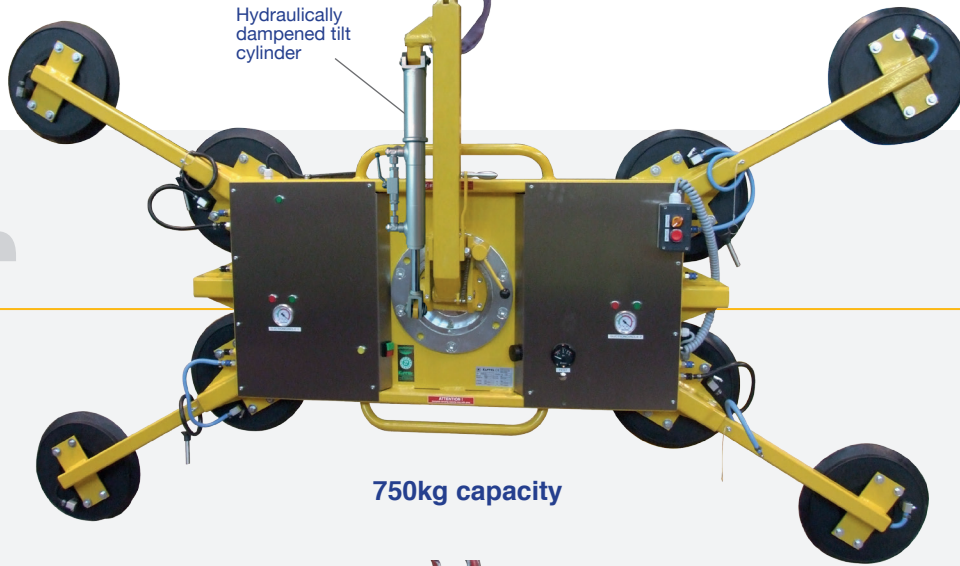

750kg capacity



Optional cable remote control

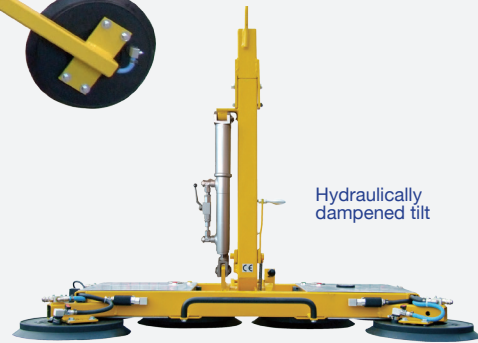

Hydraulically dampened tilt

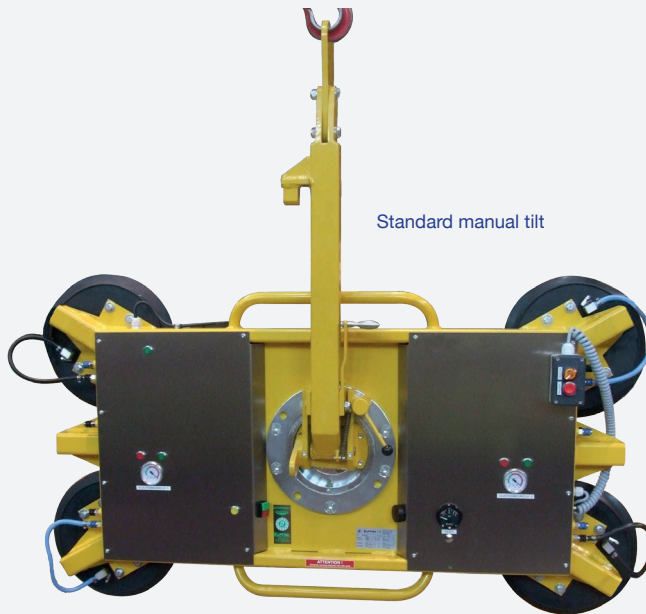

Standard manual tilt



Optional radio remote control

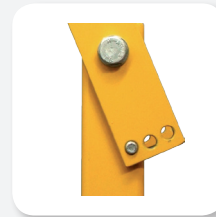

Adjustable lift bail



Optional DSZ2-L trolley  
See page 62 for more information

450kg capacity

**Technical Data (mm)**

