

Optimum Strength For

Oscar 1400 [1400kg]

Optimum Strength Compact Articulated Robot

The dual circuit Oscar 1400 is the highest capacity glazing robot in our range, it's the perfect solution for lifting and transporting a range of heavy glass, ceramic plates, plastic boards and any other non-porous materials.

With a capacity of 1400kg the Oscar 1400 offers the ultimate combination of lifting power and class beating dimensions. At just 1303mm wide with solid rubber wheels, the Oscar 1400 can easily be operated in confined spaces using the radio remote control, allowing it to carry loads through restricted access points.

The hydraulically powered robotic arm extends up to 2.3m and is able to deliver unparalleled lifting thanks to its hydraulically powered head slewing 90° left and right, 360° rotation and its ability to tilt 90° up and down.

This glazing robot also features stabilisers for added safety when going over uneven ground and a powered side shift function for moving the device exactly into position when assisting with glass installation.

Reference Code

Oscar 1400 - GRG34

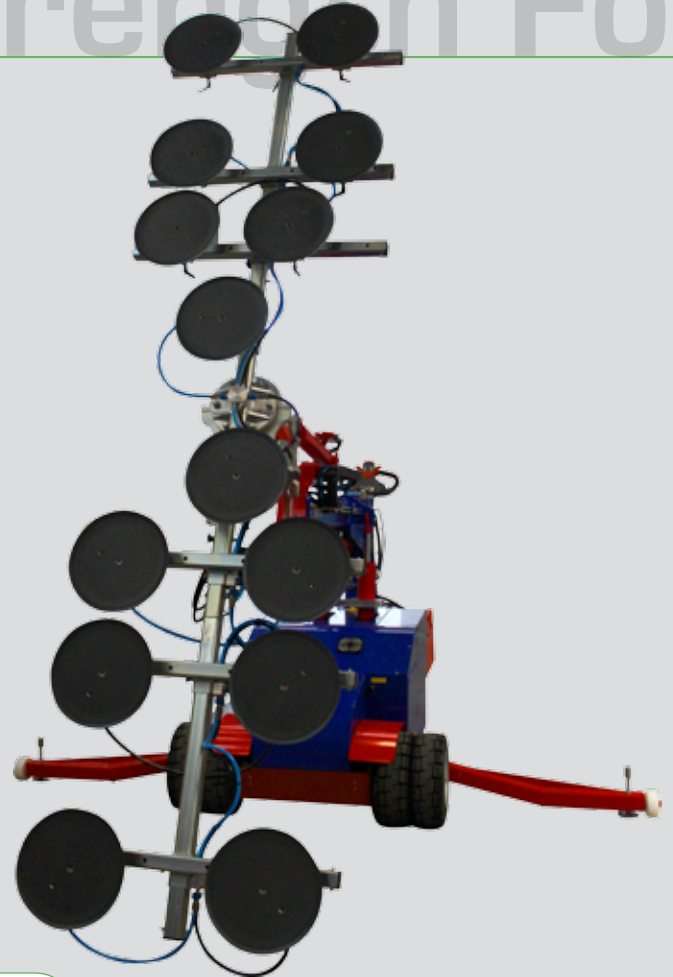

Technical Specifications

Safe working load	capacity jib 1:	1400kg
	capacity jib 2:	600kg
Suitable for lifting	material properties:	gastight / non-porous
	surface:	smooth
	example:	glass, plastic boards, ceramic plates
Weight	with counterweights:	2540kg
	without counterweights:	1862kg
Width	width:	3232mm (1303mm)
Travelling length	length:	3535mm
Travelling height	height:	1695mm
Number of suction cups	cups:	14
Powered head tilt	hydraulic head tilt:	90° up & down
Powered lateral sideshift	lateral sideshift:	100mm
Powered frame rotation	hydraulic rotation:	360°
Powered slew left & right	hydraulic head slew:	90° left & right
Boom in & out	boom in & out:	1200mm
Vacuum system	dual circuit:	4 pumps, 2 vacuum reserve tanks
Power requirements	rechargeable battery:	110v charger
	pump:	24v DC (2 x 12v)

Rated Loads Diagram

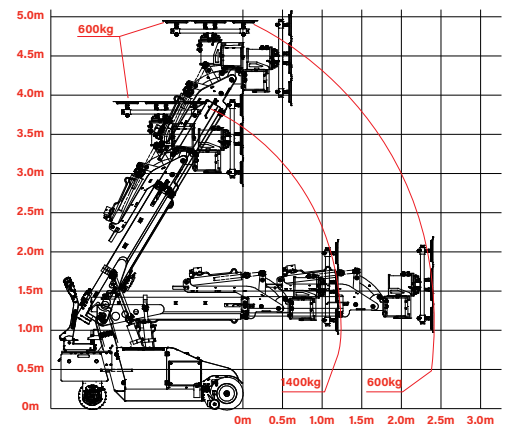



Crane hook option

Heavy Elements

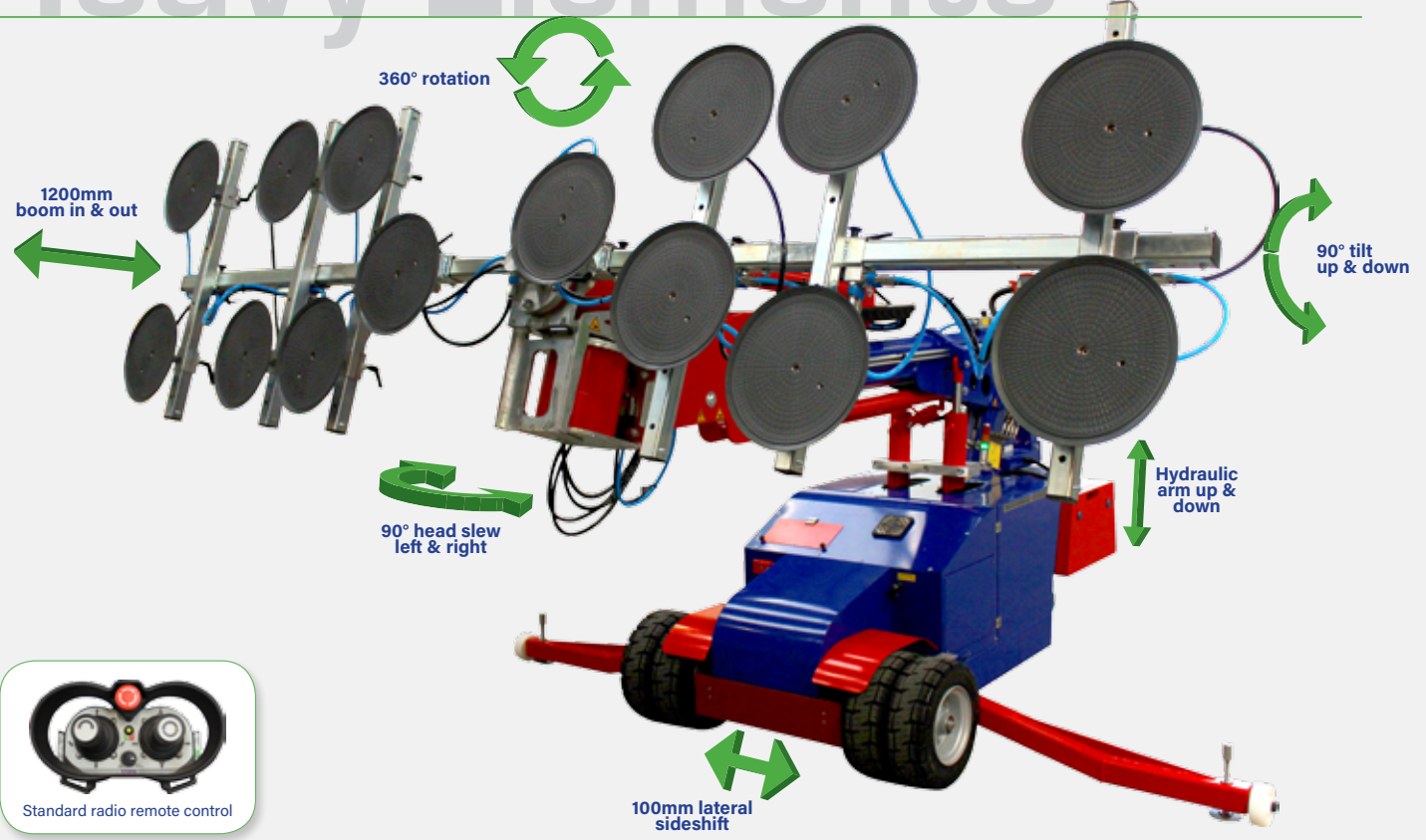

Standard radio remote control

Technical Data (mm)

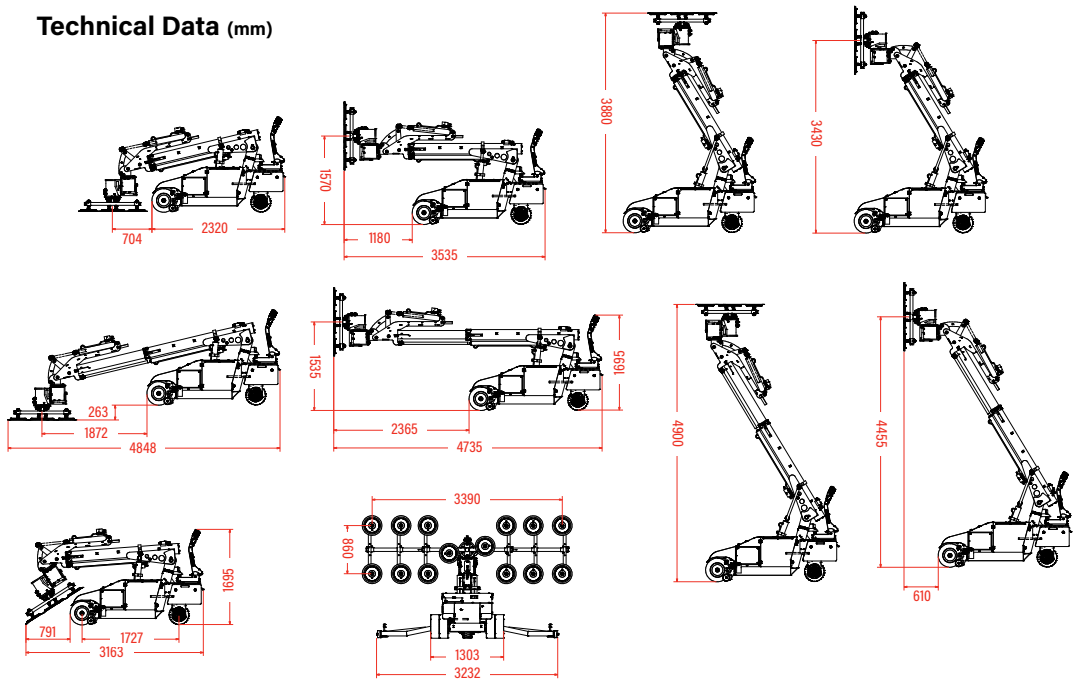

Featuring a moveable counterweight saddle for greater control.



Manual levers included as a safety feature..

