

Our Largest Capacity

Glassboy 850 [850kg]

From glass installation work and shop front glazing, to fitting loads below an overhang and general workshop lifting, the Glassboy 850 floor crane is a reliable lifting aid that suits a range of below-the-hook devices such as GGR Group's vacuum lifters.

With the ability to handle loads of up to 850kg and a maximum hook height of 2.8m, the Glassboy 850 can also be positioned between floors or on rooftops and can be used with an electric hoist to raise loads from the ground up.

This compact floor crane comes with a **long wheel** or **short wheel** base and sees the addition of outriggers for stabilising during lifting. The Glassboy 850 includes a hand pump that can be relocated to be close to the load or away from the load as required.

Its removable wheels allow the Glassboy 850 floor crane to be used on slightly uneven ground. It is a truly versatile counterbalanced floor crane thanks to its easy-to-assemble, highly portable frame, and flexibility to assist in a broad range of applications.

Reference Code

MCO23



Features include a moveable hand pump.



The Glassboy 850 can be used in a short or long wheel base configuration

Technical Specifications

Safe working load	capacity:	850kg
Weight of floor crane (long chassis)	weight:	794kg (with 20 counterweights) 556kg (with 10 counterweights) 310kg (with no counterweights)
Weight of floor crane (short chassis)	weight:	778kg (with 20 counterweights) 540kg (with 10 counterweights) 294kg (with no counterweights)
Minimum Outreach	length:	266mm
Maximum Outreach	length:	926mm
Counterweights	control:	1 box: 10x22kg / 2 boxes: 20x22kg
Standard accessories	standard:	Optional prop, removable transport wheels, solid wheels

Capacities At Each Working Length

Long Version

Position	Outreach Length	1 Box	2 Boxes
1	266mm	550kg	850kg
2	566mm	400kg	780kg
3	686mm	350kg	710kg
4	806mm	300kg	640kg
5	926mm	280kg	580kg

Capacities At Each Working Length

Short Version

Position	Outreach Length	1 Box	2 Boxes
1	266mm	350kg	750kg
2	566mm	250kg	480kg
3	686mm	220kg	450kg
4	806mm	200kg	380kg
5	926mm	170kg	350kg

Floor Crane

Glassboy 850

Key Features

- Capacity: 850kg
- Easy to assemble and highly portable
- Long or short wheel base
- Long Wheel Base Weight: 794kg approx. (with 20 counterweights), 310kg approx. (without counterweights)
- Short Wheel Base Weight: 778kg approx. (with 20 counterweights), 294kg approx. (without counterweights)

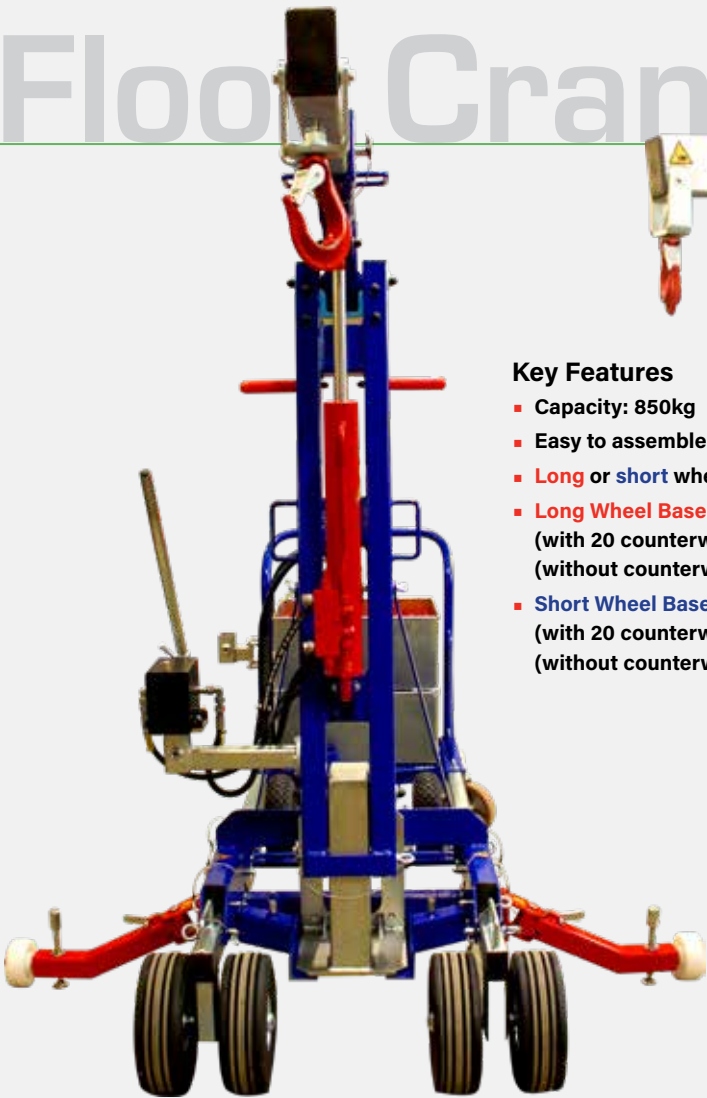

Technical Data - Solid Wheels (mm)

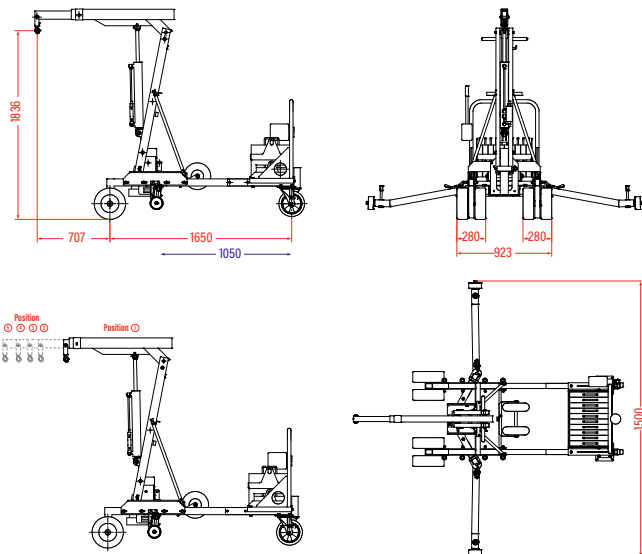

Technical Data - Castor Wheels (mm)

