



# CAMWorks®

A Geometric Product

**CERTIFIED**  
Gold  
Product

 **SOLIDWORKS**

*In the words of a CAMWorks customer...*

*"There have been parts, where a customer has needed to move some hole positions, or a pocket was moved to a different location. We used to have to reprogram the model. With CAMWorks, which can work inside SOLIDWORKS, we just change the model to the new revision, automatically regenerate the tool path, then repost it to our Mazak machines and we're ready to run. CAMWorks makes true associative machining possible."*

**Mike Blake**  
Program Manager,  
Magnus Hi-Tech

## Accelerate Your Productivity



# The Unbeatable Combination for Maximum Machining Productivity

Significantly slash your programming time by as much as 90%

CAMWorks uses feature-based machining, so part features are recognized automatically - virtually eliminating repetitive programming tasks and reducing programming time by as much as 90%. CAMWorks captures and stores your best practices so that you are able to later utilize this as a knowledge-base for easier programming.

With CAMWorks Automatic Feature Recognition and vast database of machining parameters (TechDB™), you'll be programming smarter and machining faster than ever before!

tdmsystems

PostHASTE

DMG MORI

# Complete Post Processor Support

We've teamed up with the industry's best to offer you the easiest and most comprehensive solutions possible

- Post processors for over 2000 machine tool and controller combinations will have you up and running in no time
- CAMWorks includes a Universal Post Generator (UPG) environment that enables all its users to modify existing posts or develop their own posts
- APT CL formats provided for other post processor outputs, including DMG MORI's APT CL format and PostHASTE
- Integrate with tooling information on the shop floor using tool management systems such as TDM

## How CAMWorks Accelerates Your Productivity

Use the familiar design environment for CNC programming without the hassle of file translation

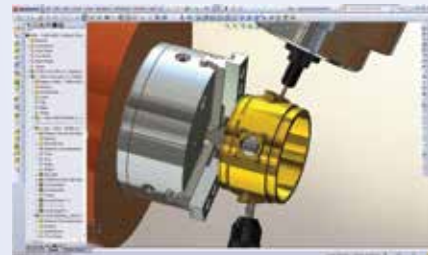

Shorter learning curve with familiar SOLIDWORKS interface

### Seamlessly integrated inside SOLIDWORKS

The first SOLIDWORKS® gold partner CAM system and by the far the most advanced CAD/CAM system on the market, CAMWorks continues to challenge traditional programming methods. Just as parametric, feature based solid modelling revolutionized mechanical design, CAMWorks parametric, feature based technology is revolutionizing CNC programming by helping users reduce programming time from hours to minutes or even seconds.

Because CAMWorks runs right inside the familiar SOLIDWORKS user interface, with the same intuitive menus, toolbars and view manipulation, users enjoy an easy-to-use solution with a short learning curve.

Improve your throughput by 3 to 4 times with your existing machines

### CAMWorks VoluMill™

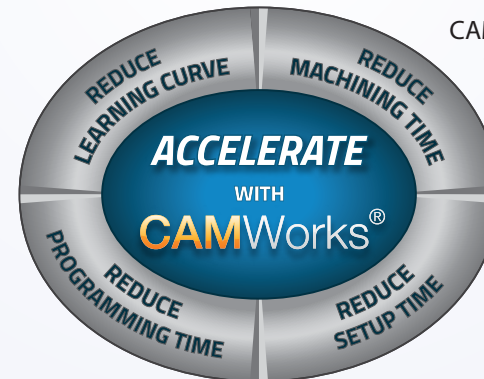

CAMWorks VoluMill is the most advanced high-performance rough milling technology available today, combining optimal milling paths with maximum material removal in the most effective way possible, to save you time and prolong the life of your cutting tools.

CAMWorks VoluMill has proven to reduce machining time by up to 80% while improving tool life up to 5 times.

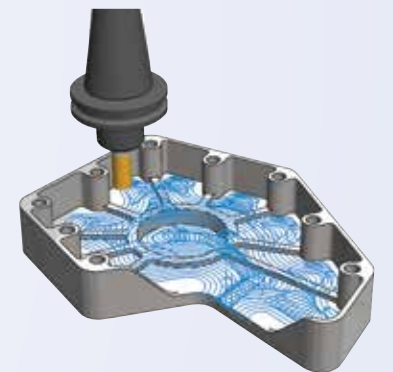

CAMWorks VoluMill handles complex geometry with ease

Eliminate CNC programming from becoming a bottleneck

### Parametric Feature Based Approach

CAMWorks takes an intuitive approach to programming a part. It treats a part as a family of machinable features, including 3-D features, and identifies appropriate machining strategies with an intelligent knowledge base to apply company's best practices. CAMWorks has the ability to interpret PMI (Product Manufacturing Information) data and choose the appropriate machining strategies. In addition, CAMWorks has the ability to automate the entire CNC programming process from end-to-end with its extensive API (Applications Programming Interface) framework.

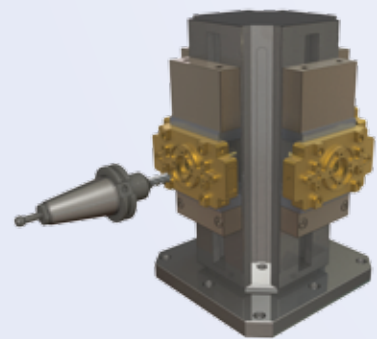

Tombstone programming in as little as 10 min

Save precious shop floor time with one-click true G-code verification

### Machine Simulation & True G-Code Verification

CAMWorks Virtual Machine allows you to see a realistic simulation of your part being machined with the complete machine tool. With true G-code simulation, you can address aspects like sub-programs, complex logic and coordinate system transformations that are not possible to address using standard CL data simulation.

In addition to saving valuable shop floor time, the integrated CAMWorks Virtual Machine environment allows you to save the time normally spent setting up a verification run in a stand-alone system.

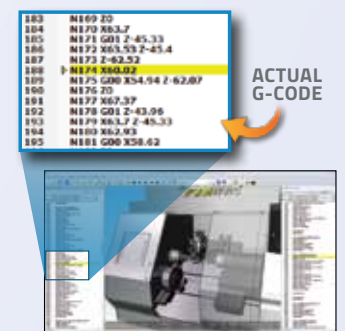

True G-code simulation helps reduce setup time by eliminating dry runs

## CAMWorks Modules

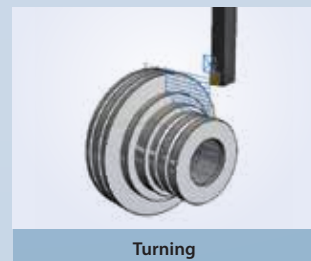
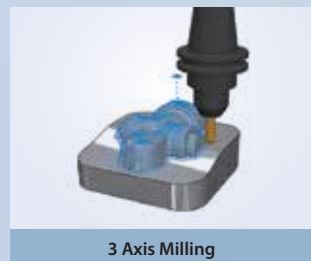

# CAMWorks Success Stories



## Reduced Programming Time with Embedded CAM

The world's largest manufacturer of amphibious boats, Sealegs International manufactures recreational and rescue crafts that can be driven in and out of water. Using the company's proprietary technology, motorized, retractable and steerable wheels are fitted to specially designed power boats, which when approaching land, can be lowered whilst still moving in water, enabling the boat to be driven onto a beach or dock. Sealegs had been using SOLIDWORKS®, and To effectively machine the required features, Sealegs decided to use a CAM package that would not only provide the best machining features but also integrate effectively with SOLIDWORKS.

"Working with CAMWorks makes it easy for us since all the CAM data is saved along with the part (design that is being machined). With CAMWorks, a programmer can be certain that he is accessing the latest version of the model together with the latest CAM data every time he checks a file out of PDM vault. This feature is quite brilliant!"

### Vladan Zubcic

Manufacturing Manager, Sealegs

## Unparalleled Machining Time

Tomak serves a wide range of customers in aerospace, medical, machine tool industries and more, offering everything from prototype work to full production runs. Using CAMWorks VoluMill, Tomak has the ability to generate optimal roughing paths with maximum material removal rates, reducing cycle times in some cases by as much as 80% and increasing cutting tool life by up to a staggering 500%!

"It's virtually seamless. Within CAMWorks you have a roughing tab with a dropdown menu ... [with] a number of different options you can choose. VoluMill is one of them. You pick VoluMill and put it to work for you. It's that simple."

### Arlie Branham

Programmer, Tomak

## Reduced Delivery Time to 1-3 Days

NCAD is a unique company in Florida that provides comprehensive services from concept to fully assembled product in one facility, without the need to outsource any aspect of the job. They established a subsidiary, MillitNow.com to offer express turnaround to its customers. With the help of CAMWorks, NCAD is able to deliver production-quality parts at prototype speeds - from received order to shipped parts in just 1 to 3 days!

"CAMWorks has been a huge part of our success in getting the NC code to the floor quickly and in having confidence in the offerings we make."

### Neil Porter

Owner, NCAD

## About Geometric

Geometric is a specialist in the domain of engineering solutions, services and technologies. Its Geometry Technology Solutions (GTS) business unit develops cutting-edge point productivity solutions that enhance design and improve manufacturing operations. The end-user products from Geometric include CAMWorks®, eDrawings® Publisher, DFMPPro, GeomCaliper®, 3DPaintBrush™ and Glovius. The key technologies from Geometric are NestLib®, Feature Recognition (FR), GeomDiff and 3DSearchIT®. Geometric licenses these technologies to OEM partners and also designs and implements customized process solutions using these technologies for industrial customers.

For further details about Geometric's GTS business unit, please visit [www.geometricglobal.com/products](http://www.geometricglobal.com/products) or call +1.480.367.0132

The copyright/trademarks of all products referenced herein are held by their respective companies.

## Contact Us

Phone US: +1.480.367.0132 Europe: +49.711.49.039.730 APAC: +91.22.67056880  
email [inquiries@camworks.com](mailto:inquiries@camworks.com)



Geometric

People Building Partnerships

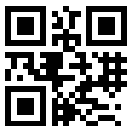

[www.camworks.com](http://www.camworks.com)