

**Model** 2018A-T  
**Capacity @ 500 mm LC** 1,800 kg  
**Power Type** Electric  
**Controller** SME

# CLG2018A-T

ELECTRIC THREE WHEEL  
PNEUMATIC TIRE FORKLIFTS



TOUGH WORLD. TOUGH EQUIPMENT.

# CLG2018A-T SPECIFICATIONS >>>

<b>General</b>	<b>Model</b>	1			2018A-T	
	<b>Power Type</b>	2			Electric	
	<b>Base Capacity</b>	3	@ rated load center	kg	1,800	
	<b>Load Center</b>	4		mm	500	
<b>Weights</b>	<b>Service Weight</b>	5	unloaded with minimum weight battery	kg	3,300	
	<b>Axle Load</b>	6	loaded, front / rear	kg	4,507 / 593	
		7	unloaded, front / rear	kg	1,549 / 1,751	
<b>Tires</b>	<b>Tires</b>	8			Pneumatic	
	<b>Wheels</b>	9	front / rear		2 / 2	
	<b>Wheelbase</b>	10		mm	1,340	
	<b>Tire Size</b>	11	front		200/50-10	
		12	rear		15x4.5-8	
	13	front / rear			915 / 180	
<b>Mast</b>	<b>Max. Fork Height</b>	14	with std 2 - stage mast	mm	3,000	
	<b>Freelift</b>	15	with std 2 - stage mast	mm	135	
	<b>Height, Upright Lowered</b>	16	with std 2 - stage mast	mm	2,045	
	<b>Height, Upright Extended</b>	17	with std 2 - stage mast	mm	4,090	
	<b>Mast Tilt, Fwd / Back</b>	18	with std 2 - stage mast	deg	6° / 7°	
	<b>Carriage</b>	19	width	mm	1,040	
	<b>Fork Spread</b>	20	minimum / maximum	mm	222 / 1,010	
	<b>Fork Dimensions</b>	21	T x W x L	mm	35 x 100 x 920	
	<b>Chassis</b>	<b>Length to Fork Face</b>	22	with std 2 - stage mast	mm	1,970
		<b>Overall Width</b>	23		mm	1,110
<b>Overhead Guard Height</b>		24		mm	2,025	
<b>Turning Radius</b>		25	minimum outside	mm	1,605	
<b>Fork Overhang</b>		26	with std 2 - stage mast	mm	385	
<b>Right Angle Stack</b>		27	add load length and clearance	mm	3,190	
<b>Ground Clearance</b>		28	minimum loaded	mm	60	
		29	center of wheelbase	mm	105	
<b>Battery Compartment</b>		30	length / width / height	mm	565 / 830 / 675	
<b>Performance</b>		<b>Travel Speed</b>	31	loaded / unloaded	kph	15 / 15
	<b>Lift Speed</b>	32	loaded / unloaded	m/s	0.35 / 0.5	
	<b>Lower Speed</b>	33	loaded / unloaded	m/s	0.5 / 0.4	
	<b>Max. Drawbar Pull</b>	34	5 min. rating	kg	1,275	
		35	60 min. rating	kg	301	
<b>Max. Gradeability</b>	36	5 min. rating	%	20		
<b>Systems</b>	<b>Controllers</b>	37	drive / hydraulic (make, type)		SME, AC	
	<b>Motors</b>	38	drive output (60 min. rating)	kW	13	
		39	hydraulic output (15 min. rating)	kW	15	
	<b>Battery</b>	40	type		Lead Acid	
		41	voltage		48	
		42	max. capacity (6 hour rating)	Ah	540	
43	weight, minimum / maximum	kg	760 / 920			

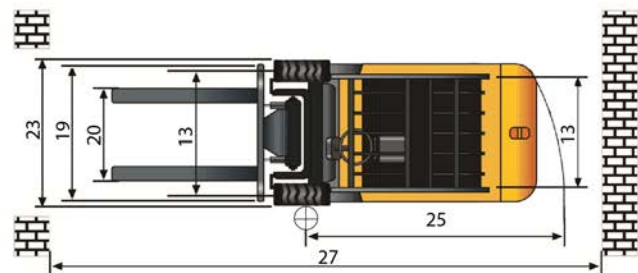
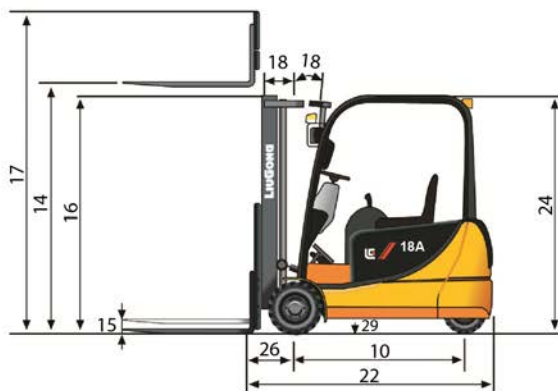

## Guangxi Liugong Machinery Co., Ltd.

No. 1 Liutai Road, Liuzhou, Guangxi 545007, PR China  
T: +86 772 3886124 E: overseas@liugong.com  
www.liugong.com

06/2014 Designed by LiuGong

Specifications and designs are subject to change without notice. Machines shown may include optional equipment.