

# CONTENTS



4-5 OIL STORAGE ADVICE

**6-23  
ABSORBENTS**

8-10 SELECTION GUIDE  
11-13 MAINTENANCE ABSORBENTS  
14-15 OIL SELECTIVE ABSORBENTS  
16-17 CHEMICAL ABSORBENTS  
18-20 ENVIRONMENTAL ABSORBENTS  
21 LOOSE ABSORBENT  
22 FLEETKLEEN™ & SPILLAWAY+™ CLEANERS  
23 WIPES

**24-38  
SPILL KITS**

26-27 SPILL KIT ADVICE  
28 VEHICLE KITS  
29 BAG KITS  
30 LIGHTWEIGHT CONTAINER KITS  
31 WHEELIE BIN & CART KITS  
32 INTERMEDIATE & MAXI CONTAINER KITS  
33 CUPBOARD KITS, SIGNS, DISPOSAL BAGS & SECURITY SEALS  
34 STATIC & OPA 90 KITS  
35 BODY FLUID ABSORBENTS & DISINFECTANT  
36 TELESTOPPER™ DRAIN SEAL  
37 FLAPSTOPPER™ DRAIN SEAL  
38 RE-USABLE & ONE TIME USE DRAIN COVERS

**39-47  
CONTAINMENT BOOMS & EQUIPMENT**

39 PERMANENT BOOMS  
40 FENCE BOOMS  
41 CURTAIN BOOMS  
42 AIR BOOMS  
43 BOOM REEL & BRUSH SKIMMERS  
44 FLOODSTOP FLOOD BARRIER  
45 FLOODSTOP CONTAINMENT BARRIER  
46 LIQUID DIVERTER & PLUGGING SYSTEMS  
47 PORTABLE CONTAINMENT BUNDS

**48-67  
DRUM & IBC STORAGE/POLYETHYLENE PRODUCTS**

50-51 PRODUCT ADVICE  
52-53 DRUM SPILL PALLETS  
54 SPILGUARD PALLET CONVERTERS  
55-57 IBC SPILL PALLETS  
58 COVERED DRUM & IBC SPILL PALLETS  
59 HARD COVERED DRUM SPILL PALLETS  
60-61 LOW PROFILE SPILL FLOORING & SPILL TRAYS  
62 FUNNELS & DRUM COVERS  
63 DRUM CRADLES  
64-65 BINS, CARTS & TROLLEYS  
66 CUPBOARDS  
67 COLUMN GUARD

**68 - 93  
DRUM & IBC STORAGE/STEEL PRODUCTS**

70-71 PRODUCT ADVICE  
72-74 DRUM SPILL PALLETS, SPILL FLOORING & TROLLEYS

75 IBC SPILL PALLETS  
76 8 TO 32 DRUM OPEN STORAGE  
77-81 FULLY ENCLOSED DRUM & IBC STORAGE  
82 FLAT PACK SELF-BUILD BUNDED STORES  
83-85 DRY GOODS, SECURE WALK-IN & FLAT PACK SELF-BUILD STORES  
86-88 TAILORED SOLUTIONS, COMPOUNDS & TEMPERATURE CONTROLLED STORES  
89 GAS CYLINDER STORES  
90-91 CHEMSTOR® CABINETS & WALK-IN STORES  
92-93 ELECTRICAL & NON-ELECTRICAL OPTIONS

**94-99  
ACCESSORIES**

96 FORK LIFT ATTACHMENTS FOR DRUM HANDLING  
97 FORK LIFT CRANES & SAFE WORKING PLATFORM  
98 DRUM TROLLEYS, DISPENSING & STORAGE RACK  
99 SMOKERS CEASE-FIRE® FREE STANDING CIGARETTE BIN

**100-23  
HAZARDOUS MATERIAL & FIRE RATED PRODUCTS**

102-104 PRODUCT ADVICE  
105 STORAGE VAULTS  
106-07 60 MINUTE FIRE-RATED DRUM & IBC STORES  
108-112 FM APPROVED, UK STANDARD & 90 MINUTE CABINETS  
113-116 FLAMMABLE LIQUID SAFETY CANS  
117 LIQUID DISPENSING  
118 DIP & FLOOR STANDING RINSE TANKS  
119 DRUM COVERS & DRUM LOCKS  
120 WASTE CONTAINERS  
121-123 SAFETY FUNNELS, DRUM TAPS, VENTS & ANTI-STATIC WIRES

**124-129  
EMERGENCY SHOWERS, EYE & FACE WASH SYSTEMS**

126 SHOWER & PORTABLE SYSTEMS  
127 WALL MOUNTED SHOWERS  
128 EYE WASH & EYE/FACE WASH BASINS  
129 LABORATORY HOSES

**130-135  
DOUBLE SKINNED TANKS**

132 PRODUCT ADVICE  
133 WASTE OIL TANKS  
134 DIESEL DISPENSING TANKS  
135 LIQUID STORAGE TANKS

**136-144  
WASTE HANDLING**

138 PRODUCT ADVICE  
139 AUTO TIPPING SKIPS  
140-141 AUTO DUMPING SKIPS  
142-143 ROLL FORWARD SKIPS  
144 SKIP CANOPIES

# THE WATER ENVIRONMENT (OIL STORAGE) (SCOTLAND) REGULATIONS 2006

For regulation information and advice contact us or visit [www.sepa.org.uk](http://www.sepa.org.uk)

## DO THE REGULATIONS APPLY TO ME?

YES if you store any of the following kinds of oil:

- Petrol
- Diesel
- Mineral oil
- Heating oil
- Lubricating oil
- Waste oil
- Vegetable and plant oil

- The regulations apply to any kind of container which is used and stored on premises above ground, whether inside or outside a building. This includes fixed tanks, intermediate bulk containers, drums (oil drums or similar containers used for storing oil) or mobile bowsers.

- The container must be situated within a secondary containment system which satisfies the following requirements: It must have a capacity of not less than 110% of the container's storage capacity or, if there was more than one container within the system, of not less than 110% of the largest container's storage capacity, or 25% of the aggregate storage capacity, whichever is greater.

## KEY REQUIREMENTS OF THE REGULATIONS

The regulations set design standards for new and existing above-ground oil storage facilities:

- Where oil is stored in any portable container with a storage capacity of less than 200ltr, the container must be of sufficient strength and structural integrity to ensure that it is unlikely to burst or leak in its ordinary use.

- Where the container has a storage capacity of 200ltr or more, the regulations require provision of a secondary containment (a bund or drip-tray) to ensure that any leaking or spilled oil cannot enter the water environment.

## IS STORAGE WITHIN BUILDINGS COVERED BY THE REGULATIONS?

- YES Oil storage within buildings must comply with the regulations.

## DO THE REGULATIONS COVER MOBILE BOWSERS USED AT LICENSED WASTE SITES?

- YES Mobile bowsers used at all licensed waste sites must comply with the regulations.

## DO THE REGULATIONS COVER THE VOLUME OF OIL STORED OR THE SIZE OF THE CONTAINER?

- The regulations cover the size of the container. For example, sites with an oil tank of 1000ltr which only ever have 150ltr of oil stored would still have to comply.



# THE CONTROL OF POLLUTION (OIL STORAGE) (ENGLAND) REGULATIONS 2001

For regulation information and advice contact us or visit [www.netregs.gov.uk](http://www.netregs.gov.uk)

## WHERE DO THE REGULATIONS APPLY?

- ONLY in England
- The container must be situated within a secondary containment system which satisfies the following requirements: It must have a capacity of not less than 110% of the container's storage capacity or, if there was more than one container within the system, of not less than 110% of the largest container's storage capacity, or 25% of the aggregate storage capacity, whichever is greater.

## WHAT TYPES OF OIL CONTAINERS ARE COVERED BY THE REGULATIONS?

The regulations apply to:

- Tanks (can be permanent or temporary)
- Drums greater than 200ltr capacity
- Intermediate bulk containers (IBCs)
- Mobile bowzers
- Oil storage containers can be made from a variety of materials, for example polyethylene or metal, but all should be designed and manufactured to hold oil and must be 'fit for purpose' while they are being used. The Environment Agency regard an Intermediate Bulk Container (IBC) as being permanent oil storage and the requirements for fixed tanks apply.

## WHICH TYPES OF OIL ARE COVERED?

- The regulations cover all types of oil, except waste mineral oil. This includes petrol, diesel, bio-fuels, vegetable oils, synthetic, mineral oils and oils used as solvents. Biodegradable oils are also covered.

## ARE CROWN SITES EXEMPT?

- NO they must comply with the regulations, although the Environment Agency can't prosecute for non-compliance, they can ask the court to serve a notice which would require improvements to be put in place.

## DO THE REGULATIONS COVER THE VOLUME OF OIL STORED OR THE SIZE OF THE CONTAINER?

- The regulations cover the size of the container. For example, sites with an oil tank of 1000ltr which only ever have 150ltr of oil stored would still have to comply.

## ARE THERE DIFFERENCES BETWEEN THE SCOTTISH AND ENGLISH REGULATIONS?

**YES** they differ slightly, here are 3 key differences:

- Regulations in Scotland apply to storage of waste oil. The storage of waste mineral oils is exempt under the English regulations because it is covered by The Waste Management Licensing Regulations 1994
- Regulations in Scotland apply to storage of oil in buildings while the English regulations exempt the storage of oil within a building
- The Scottish regulations require that if oil is stored in a portable container of <200ltr, the container must be of sufficient strength and structural integrity that it doesn't leak in ordinary use. There is no similar requirement in the English regulations.



# ABSORBENTS



# BEST BUYS

For day to day response to minor **MAINTENANCE** spills use **GP101** – 200 pads for £59.00 which equates to 2.95p to absorb 0.72ltr – SEE PAGE 11



For **OIL SELECTIVE** applications where you only have “oils” try **BS1** socks to contain and absorb the spilt or leaking liquid 20 socks that absorb 4ltr each for £50 - £2.50 each – SEE PAGE 15



**CHEMICAL** spills need fast response and with our highly visible yellow products you can't go wrong. A pack of 50 **CP102** pads are small enough to store easily but absorbent enough to give you 36ltr capacity from one pack and at only £24.00 – At 4.8p per pad they are great value too – SEE PAGE 16



**ENVIRONMENTAL** spill response is the highly visible face of pollution. Booms deployed at an outfall are a great proactive tool, **WB13** are economical but highly effective. A pack of 4 booms gives you 140ltr of absorbency for only £109.00 or 77.8p per ltr – SEE PAGE 20



# HOW TO SELECT THE RIGHT ABSORBENTS FOR YOUR APPLICATIONS

For advice or to arrange a site assessment please contact us on **01506 430309/advice@empteezy.co.uk**

## ASSESSMENT

- By understanding what happens on your site you will be better placed to respond in the event of an emergency. Let us carry out your assessment, an outside pair of eyes often sees things that have become commonplace to you.

## KNOW WHAT LIQUIDS YOU HAVE

- You need to know which liquids you have on site, what risks they pose (check Material Safety Data Sheets) what volumes, in what sizes of container and how many of each you have.

## WHERE YOUR LIQUIDS ARE STORED AND USED

- Check how liquids are delivered to site, how they are unloaded and moved around the site, where they are stored and in which applications they are used.

## WHICH TYPE(S) OF ABSORBENT(S) ARE BEST FOR YOU

- Once you understand your site, and where and how liquids are transported, stored and used, you will be better placed to select the correct products to best suit you.

## CONTACT US

- Contact us today to arrange a site survey and reduce the risk of you and your company being liable to prosecution. Tel 01506 430309 or email [advice@empteezy.co.uk](mailto:advice@empteezy.co.uk)

## DEALING WITH DAY TO DAY HOUSEKEEPING AND RESPONDING TO EMERGENCIES

- Choosing the right absorbents and spill kits is only the start of the process, you need your staff to know how to use them safely and properly which will result in cost effective use. There is nothing worse than products turning up and no one taking the time to explain what they are and how to use them safely and effectively.

## OUR OFFER

- As an ISO 9001, ISO 14001 & ISO 18001 accredited company (the only one in our industry to hold all 3) with more than 25 years experience you can trust us to assess your site, recommend the right products for your applications and train your staff, monitor your stocks and spill kit contents for you. See pages 25-26 for further details.

## TESTING & SELECTION





- All our absorbency performance figures are based on evaluation using BS 7959 and we are members of The British Safety Industry Federation Sorbents Manufactures Group and as such have, in conjunction with the Environment Agency produced a pamphlet "Guidance on selection for the use of sorbent" which is freely available from us on request.



# SELECTION GUIDE

## COLOUR CODED ABSORBENTS THAT CONFORM TO BRITISH STANDARD BS 7959

To order please contact us on **01506 430309**/[www.empteezy.co.uk](http://www.empteezy.co.uk)

APPLICATION	LIQUIDS	COLOUR	NAME
<p>Day to day leaks and drips from plant &amp; machinery that could spread into walkways</p> <p>Drips &amp; overspray from conveyors, valves etc.</p>	<p>Oils, coolants, cutting fluid, mild solvents, water etc.</p>	<p>Grey</p> <p>To blend into the workplace environment</p>	<p><b>MAINTENANCE</b></p> 
<p>Day to day leaks and drips from plant &amp; machinery that could spread into walkways</p> <p>Drips &amp; overspray from conveyors, valves etc.</p>	<p>Fuel oil, lubricating oil, cutting oil etc. In fact any hydrocarbon</p>	<p>Blue</p> <p>To identify it as oil selective and to blend into the workplace</p>	<p><b>MAINTENANCE OIL SELECTIVE</b></p> 
<p>Spills in laboratories</p> <p>Drips and overspray from dip tanks etc.</p>	<p>Acids, alkalis, hydrocarbons, coolants, cutting fluids, water etc. Infact almost any liquid</p>	<p>Yellow</p> <p>To stand out and easily be identified as potentially "Hazardous"</p>	<p><b>CHEMICAL</b></p> 
<p>Outdoor spills either land based or on water</p>	<p>All types of hydrocarbon, oils, fuel, petrol etc.</p>	<p>White</p> <p>To stand out and be seen when dealing with environmental incidents</p>	<p><b>ENVIRONMENTAL OIL SELECTIVE</b></p> 

All our prices include delivery to a mainland UK address



# APPLICATION SELECTION GUIDE

## IMPROVE HOUSEKEEPING, CONTROL LEAKS & SPILLS IN THE WORKPLACE

For further advice on absorbents please contact us on [01506 430309](tel:01506430309)/[advice@empteezy.co.uk](mailto:advice@empteezy.co.uk)

### MATCH THE RIGHT PRODUCT TO YOUR APPLICATION

	SOCKS	BOOMS	PADS & ROLLS	CUSHIONS	DRIP TRAY
Leaks from machines that runs into walkways	✓				
Drips from pipes, valves, glands etc.			✓	✓	✓
Overspray from machinery			✓		
Leaks & drips from conveyors belts			✓		
Lining parts bins, trolleys, shelves etc.			✓		
Drips & splashes from dip tanks & parts washers			✓		
Spills from over full drip trays				✓	✓
Slippery wheels on fork lift trucks					
Spills & leaks in labs/test facilities	✓		✓	✓	
Leaking drums/IBC's	✓	✓	✓	✓	
Leaks & spills at fuel delivery points	✓	✓	✓	✓	
Leaks & spills at fuel pumps	✓	✓	✓	✓	

### EMPTEEZY'S CONTAINED ABSORBENTS

- More effective and less time consuming to clean-up than clay granules, sawdust, rags etc. These products are available in different formats to suit different applications and can be used pro-actively as part of day to day housekeeping or as part of an emergency response program. They are quick to deploy, fast to recover and are disposed of in accordance with local authority guidelines (they can be incinerated to less than 1% ash)
- We even offer 2 lines to further ensure you have the right product for your specific application.

### EEZYSORB®

- Performance and economy, this comprehensive range is best suited to most applications and has proven to be cost effective too.

# ABSORBENTS EEZYSORB® GREY MAINTENANCE PADS & ROLLS

For most liquids found in manufacturing from oils and coolants to mild solvents and water. Coloured grey to blend in and be unobtrusive in the workplace.

To order please contact us on **01506 430309**/[www.empteezy.co.uk](http://www.empteezy.co.uk)

## PADS

- Wipe up minor drips and spills quickly without any fuss
- Line component bins to contain drips
- Soak-up contained spills.

## ROLLS

- Line work benches to improve housekeeping
- Run a length out under a conveyor belt to catch drips
- Line a sump or banded pallet to make cleaning easier.

## ROLL HOLDER

- Keep your absorbent rolls off the floor
- Make life easier when dispensing a section of absorbent roll.



## PADS & ROLLS

All our prices include delivery to a mainland UK address

MODEL	SIZE	QTY & ABSORBENCY	DELIVERED PRICE
GP102	40cm x 50cm pads	36ltr per pack of 50 - 0.72ltr per pad (2kg)	£23.00
GP201	40cm x 50cm pads	113ltr per pack of 100 - 1.13ltr per pad (6.8kg)	£59.00
GP101	40cm x 50cm pads	144ltr per pack of 200 - 0.72ltr per pad (8.1kg)	£59.00
GR102	40cm x 60m rolls	173ltr per pack of 2 - 86.5ltr per roll (9.9kg)	£98.00
GR101	80cm x 60m roll	173ltr per pack of 1 (9.9kg)	£98.00
<b>ROLL HOLDERS</b>			
RH1	47cm x 55cm x 60cm high	Metal self assembly roll holder	£50.00
RHA	65cm x 63cm x 58cm high	Polyethylene counter top roll dispenser	£92.00

# ABSORBENTS

## EEZYSORB® GREY MAINTENANCE SOCKS & BOOMS

Maintenance absorbents like these will absorb oil and water based liquids, such as coolants and cutting fluid. If you don't want to absorb water based liquids please see our Oil Selective range.

For advice on absorbents please contact us on [01506 430309](tel:01506430309)/[advice@empteezy.co.uk](mailto:advice@empteezy.co.uk)



### SOCKS

- Think of them as a portable dam stopping liquids as they flow
- Small diameter makes them easy to use in the workplace
- Place around the base of leaking machinery to contain and absorb liquid and stop it spreading into walkways where it can cause a slip hazard
- Use as part of your spill response program.

### BOOMS

- Respond to large scale spills
- Contain and absorb large amounts of liquid quickly.

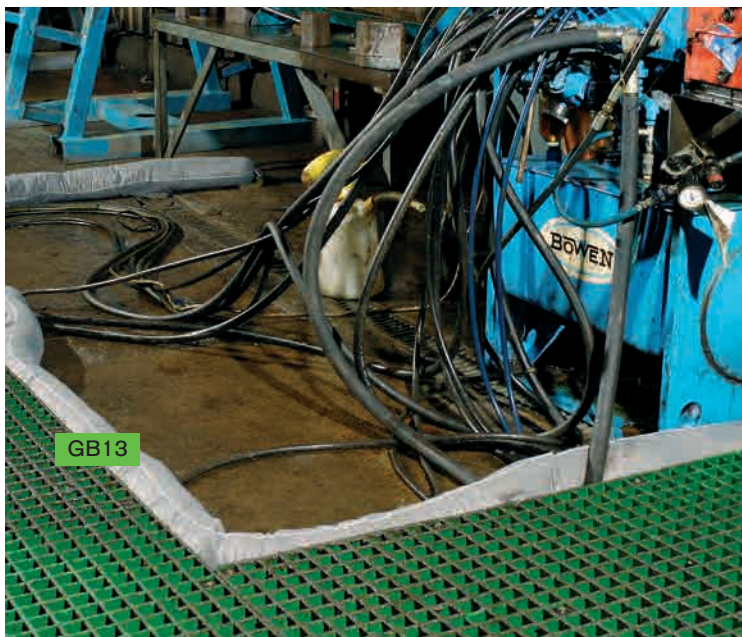

### SOCKS & BOOMS

All our prices include delivery to a mainland UK address

MODEL	SIZE	QTY & ABSORBENCY	DELIVERED PRICE
GS1	7.5cmØ x 1.2m socks	80ltr per pack of 20 - 4ltr per sock (9.2kg)	£62.00
GS2	7.5cmØ x 3m socks	80ltr per pack of 8 - 10ltr per sock (9.2kg)	£74.00
GB13	13cmØ x 3m booms	150ltr per pack of 4 - 37.5ltr per boom (11.1kg)	£120.00

# ABSORBENTS EEZYSORB® GREY MAINTENANCE CUSHIONS

Colour coded grey to conform with the British Standard BS 7959 these products help you absorb liquids typically found in an industrial environment from water and oils to mild solvents.

To order please contact us on **01506 430309**/[www.empteezy.co.uk](http://www.empteezy.co.uk)

## CUSHIONS

- Line existing drip trays to make them easier to empty, no more spilt liquid when trying to move them
- Disassemble expensive components such as valves, in situ and not only will you catch any liquid residues but protect the component from damage too
- Use in conjunction with socks or booms to absorb large amounts of liquid quickly.



## CUSHIONS

All our prices include delivery to a mainland UK address

MODEL	SIZE	QTY & ABSORBENCY	DELIVERED PRICE
GC1	40cm x 40cm cushions	110ltr per pack of 16 - 6.9ltr per cushion (9.2kg)	£79.00

# ABSORBENTS EEZYSORB® BLUE OIL SELECTIVE MAINTENANCE PADS & ROLLS

Specifically for oils and fuels these products don't absorb water they repel it, and they are colour coded blue in accordance with British Standard BS 7959 to indicate that they are Oil Selective.

For advice or to arrange a site assessment call or email on [01506 430309](tel:01506430309)/[advice@empzeezy.co.uk](mailto:advice@empzeezy.co.uk)



BP201

## PADS

- Wipe up minor drips and spills quickly without any fuss
- Line component bins to contain drips
- Soak-up contained spills.

## ROLLS

- Line work benches to improve housekeeping
- Run a length out under a conveyor belt to catch drips
- Line a sump or banded pallet to make cleaning easier.

## ROLL HOLDER

- Keep your absorbent rolls off the floor
- Make life easier when dispensing a section of absorbent roll.



BR101



BR102



RHA

## PADS & ROLLS

All our prices include delivery to a mainland UK address

MODEL	SIZE	QTY & ABSORBENCY	DELIVERED PRICE
BP102	40cm x 50cm pads	36ltr per pack of 50 - 0.72ltr per pad (2kg)	£21.00
BP201	40cm x 50cm pads	113ltr per pack of 100 - 1.13ltr per pad (6.8kg)	£54.00
BP101	40cm x 50cm pads	144ltr per pack of 200 - 0.72ltr per pad (8.1kg)	£54.00
BR102	40cm x 60m rolls	173ltr per pack of 2 - 86.5ltr per roll (9.9kg)	£92.00
BR101	80cm x 60m roll	173ltr per pack of 1 (9.9kg)	£92.00
<b>ROLL HOLDERS</b>			
RH1	47cm x 55cm x 60cm high	Metal self assembly roll holder	£50.00
RHA	65cm x 63cm x 58cm high	Polyethylene counter top roll dispenser	£92.00

# ABSORBENTS

## EEZYSORB® BLUE OIL SELECTIVE MAINTENANCE SOCKS & CUSHIONS

These products repel water and water based liquids, only absorbing oils and fuels, they are easily identified by their blue colour.

To order please contact us on **01506 430309**/[www.empteezy.co.uk](http://www.empteezy.co.uk)

### SOCKS

- Think of them as a portable dam stopping liquids as they flow
- Small diameter makes them easy to use in the workplace
- Place around the base of leaking machinery to contain and absorb liquid and stop it spreading into walkways where it can cause a slip hazard
- Use as part of your spill response program.

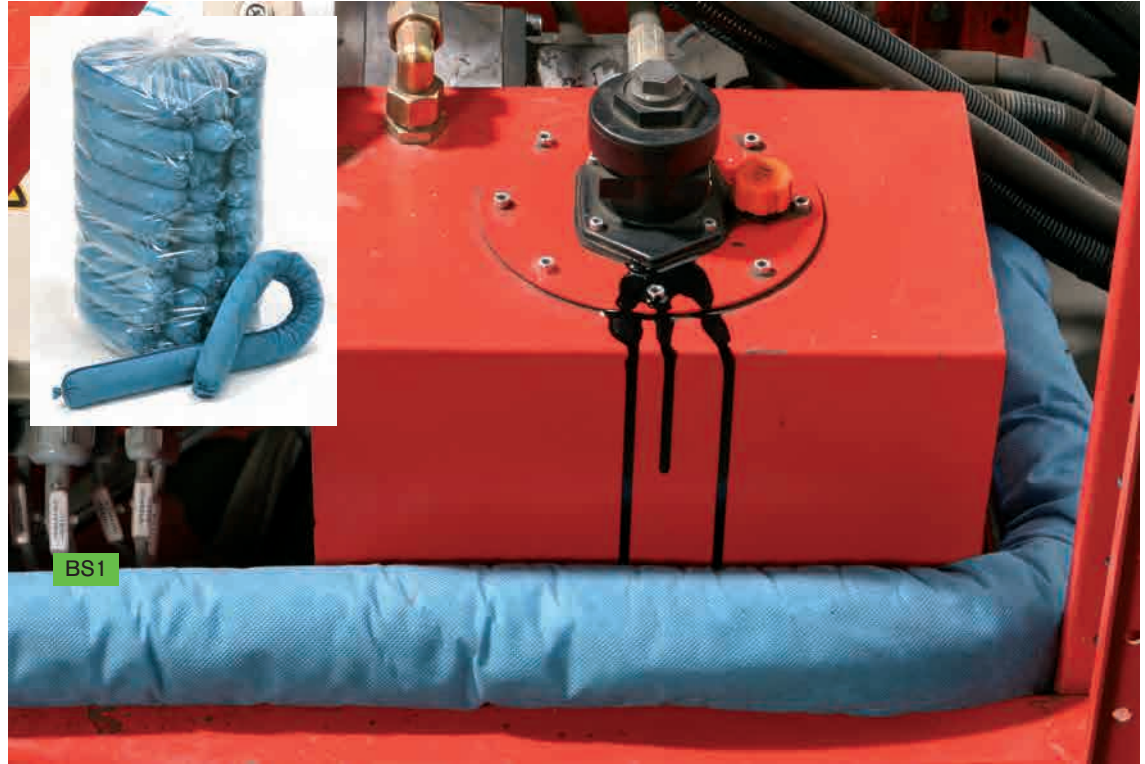

BS1

### CUSHIONS

- Line existing drip trays to make them easier to empty, no more spilt liquid when trying to move them
- Disassemble expensive components such as valves, in situ and not only will you catch any liquid residues but protect the component from damage too
- Use in conjunction with socks or booms to absorb large amounts of liquid quickly.



BC1

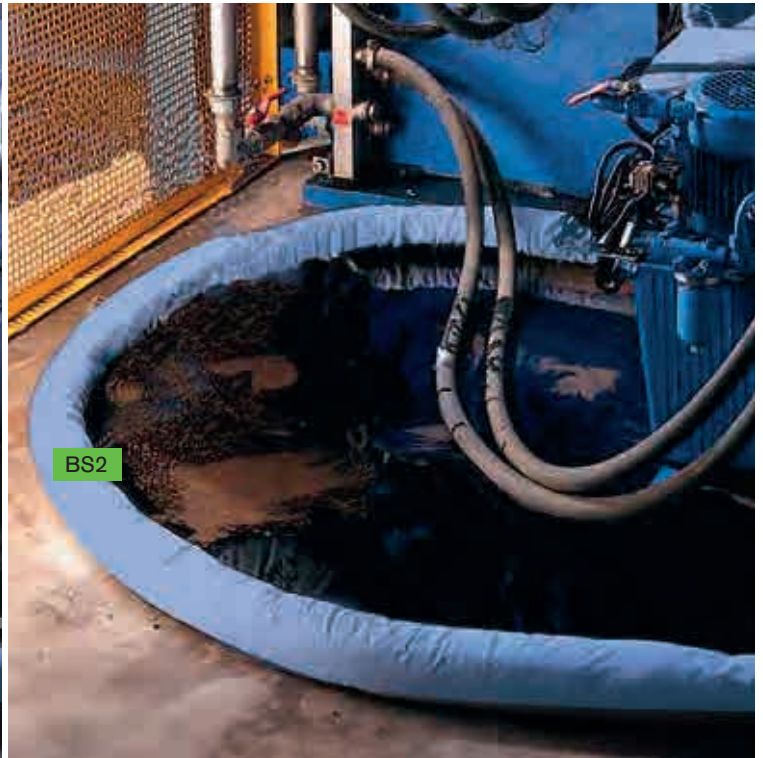

BS2

### SOCKS & CUSHIONS

All our prices include delivery to a mainland UK address

MODEL	SIZE	QTY & ABSORBENCY	DELIVERED PRICE
BS1	7.5cmØ x 1.2m socks	80ltr per pack of 20 - 4ltr per sock (9.2kg)	£50.00
BS2	7.5cmØ x 3m socks	80ltr per pack of 8 - 10ltr per sock (9.2kg)	£72.00
BC1	40cm x 40cm cushions	110ltr per pack of 16 - 6.9ltr per cushion (9.2kg)	£74.00

# ABSORBENTS EEZYSORB® YELLOW CHEMICAL PADS & ROLLS

For Acids, Alkalis, Hydrocarbons and Water, especially useful when you are unsure what the spilt liquid is. Coloured yellow to stand out and easily be identified as a potential hazard.

For advice on absorbents please contact us on [01506 430309](tel:01506430309)/[advice@empteezy.co.uk](mailto:advice@empteezy.co.uk)



## PADS

- Quickly wipe up minor spills
- Line lab/test facility benches during experiments
- Absorb already contained spilt liquid.

## ROLLS

- Catch drips and overspray from chemical dip tanks
- Use as part of your response to a major spill.

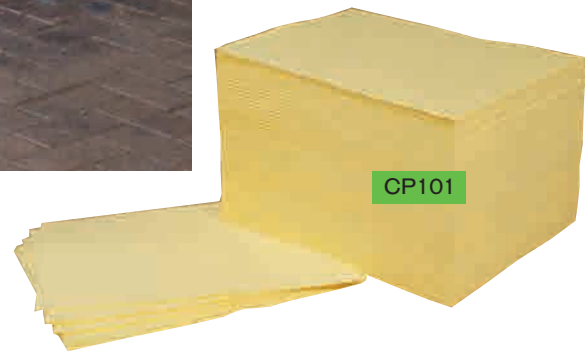

## PADS & ROLLS

All our prices include delivery to a mainland UK address

MODEL	SIZE	QTY & ABSORBENCY	DELIVERED PRICE
CP102	40cm x 50cm pads	36ltr per pack of 50 - 0.72ltr per pad (1.9kg)	£24.00
CP201	40cm x 50cm pads	113ltr per pack of 100 - 1.13ltr per pad (6.8kg)	£64.00
CP101	40cm x 50cm pads	144ltr per pack of 200 - 0.72ltr per pad (8.1kg)	£64.00
CR102	40cm x 60m rolls	173ltr per pack of 2 - 86.5ltr per roll (9.9kg)	£105.00

# ABSORBENTS

## EEZYSORB® YELLOW CHEMICAL SOCKS, BOOMS & CUSHIONS

For Acids, Alkalis, Hydrocarbons and Water or when you are in doubt as to what the spilt liquid is, use Chemical absorbents because they will absorb almost anything.

To order please contact us on **01506 430309**/[www.empteezy.co.uk](http://www.empteezy.co.uk)

### SOCKS

- Think of them as a portable dam stopping liquids as they flow
- Contain and absorb small scale spills.

### BOOMS

- Contain and absorb major spills quickly and stop the liquid from spreading.

### CUSHIONS

- Line existing drip trays making them easier to empty, no more spilt liquid when trying to move them
- Soak up large amounts of liquid quickly.



### SOCKS, BOOMS & CUSHIONS

All our prices include delivery to a mainland UK address

MODEL	SIZE	QTY & ABSORBENCY	DELIVERED PRICE
SCS1	7.5cmØ x 1.2m socks	80ltr per pack of 20 - 4ltr per sock (9.2kg)	£85.00
SCS2	7.5cmØ x 3m socks	80ltr per pack of 8 - 10ltr per sock (9.2kg)	£102.00
CB13	13cmØ x 3m booms	140ltr per pack of 4 - 35ltr per boom (11.1kg)	£148.00
CC1	40cm x 40cm cushions	110ltr per pack of 16 - 6.9ltr per cushion (9.2kg)	£108.00
CC501	30cm x 52cm cushions	41.5ltr per pack of 20 - 2.06ltr per cushion (2.7kg)	£49.00



# ABSORBENTS

## EEZYSORB® & MICROSORB®

### WHITE OIL SELECTIVE ENVIRONMENTAL

The white colour not only stands out but also makes it very easy to see when the product needs replacing, an important factor when dealing with spills that could impact on the environment.

For advice on absorbents please contact us on **01506 430309/advice@empteezy.co.uk**

#### MATCH THE RIGHT PRODUCT TO YOUR APPLICATION

	PADS & ROLLS	SEALS	BOOMS	CUSHIONS
Discharge to surface water drains		✓		✓
Discharge to rivers, streams, lakes, marinas etc.	✓		✓	✓
Discharge to settling ponds			✓	✓
Spills from vehicles onto the ground	✓	✓	✓	✓
Leaks from drums & IBC's	✓	✓	✓	✓
Leaks & spills at fuel delivery points	✓	✓	✓	✓
Leaks & spills at fuel pumps	✓	✓	✓	✓
Spills during the movement of drums & IBC's by fork lift truck	✓	✓	✓	✓

#### EMPTEEZY'S CONTAINED ABSORBENTS

- When dealing with “outdoor” spills we tend to think about oil tankers running aground, rupturing their tanks and causing a major environmental incident. Although these cases do occur, fortunately they are still a relatively rare occurrence. However, land based spills account for more than 5,000 pollution incidents involving oil and fuels every year. Although some of these affect land, the vast majority affect the water environment. On average an oil spill costs a typical business up to £30,000 in fines, clean up charges and production losses
- Oil is a highly visible pollutant that affects the environment in a number of ways. It can reduce levels of dissolved oxygen and taint drinking water supplies at very low concentrations, making them unsuitable for use, and it can harm wildlife. Wildfowl are particularly vulnerable, both through damage to the waterproofing of their plumage and through ingestion of oil during preening. Mammals such as water voles may also be affected. The flesh of fish exposed to oil can become tainted
- Oil is everywhere in society. It is used in large quantities, requiring an extensive distribution and storage system. Opportunities for spills and other accidental releases are probably greater than any other type of chemical pollutants. The principal causes of oil pollution are loss from storage facilities, spillage during delivery and deliberate disposal of waste oil to drainage systems
- Our range of products will cover most of the applications you may encounter but as always if you can't find what you are looking for please contact us to discuss your specific application.

# ABSORBENTS

## EEZYSORB® WHITE OIL SELECTIVE ENVIRONMENTAL PADS & ROLLS

Specifically for hydrocarbons i.e. oils, diesel etc. (repels water) these products allow you to respond quickly and effectively to spills on land (don't absorb water when it's raining) or on water.

To order please contact us on **01506 430309**/[www.empteezy.co.uk](http://www.empteezy.co.uk)

### PADS

- Soak up minor spills quickly before they spread
- Line the drip tray at your refueling point
- Line the base of your "swarf bins" to stop oil escaping.

### ROLLS

- Cover large areas quickly
- Reduce contamination where a spill comes into contact with the shore
- Can be rolled out from the back of a boat to deal with spills on calm water.



### PADS & ROLLS

All our prices include delivery to a mainland UK address

MODEL	SIZE	QTY & ABSORBENCY	DELIVERED PRICE
WDP201	40cm x 50cm pads	113ltr per pack of 100 - 1.13ltr per pad (6.1kg)	£77.00
WDP101	40cm x 50cm pads	144ltr per pack of 200 - 0.72ltr per pad (7.3kg)	£79.00
WDR102	40cm x 60m rolls	173ltr per pack of 2 - 86.5ltr per roll (9.9kg)	£91.00
WDR101	80cm x 60m roll	173ltr per pack of 1 (9.9kg)	£91.00

# ABSORBENTS

## EEZYSORB® & MICROSORB® WHITE OIL SELECTIVE ENVIRONMENTAL BOOMS & CUSHIONS

Specifically for hydrocarbons i.e. oils diesel etc. (repels water) these products allow you to contain and then absorb hydrocarbons quickly and effectively. Their design means that they have no effective shelf life and can be deployed pro-actively at places prone to spills.

For advice on absorbents please contact us on [01506 430309](tel:01506430309)/[advice@empteezy.co.uk](mailto:advice@empteezy.co.uk)



WB13

### BOOMS

- Contain and absorb land based spills of hydrocarbons even when it's raining
- Deploy proactively at spill prone areas such as outfalls from your site
- MICROSORB® pure fibre booms absorb up to 187ltr per boom.

### CUSHIONS

- Deploy proactively into spill prone surface water drains on a lanyard for easy retrieval
- Use to aid clean-up after a major spill.



WB43



WC3

### BOOMS & CUSHIONS

All our prices include delivery to a mainland UK address

MODEL	SIZE	QTY & ABSORBENCY	DELIVERED PRICE
WB13	13cmØ x 3m booms	140ltr per pack of 4 - 35ltr per boom (11.1kg)	£109.00
WB15	13cmØ x 5m booms	114ltr per pack of 2 - 57ltr per boom (9.1kg)	£103.00
WB43	20cmØ x 3m pure fibre booms	372ltr per pack of 4 - 93ltr per boom (17kg)	£206.00
WB45	20cmØ x 5m pure fibre booms	284ltr per pack of 2 - 142ltr per boom (13kg)	£161.00
WC3	30cm x 60cm cushions	140ltr per pack of 10 - 14ltr per cushion (11.2kg)	£95.00

# ABSORBGANIC SPILL DOCTOR™ LIGHTWEIGHT LOOSE ABSORBENT

A highly absorbent, non toxic, non abrasive free flowing absorbent

To order please contact us on **01506 430309**/[www.empteezy.co.uk](http://www.empteezy.co.uk)



## ABSORBGANIC

– A 100% natural product blended from waste plant matter, which means it does not add to the non-biodegradable waste stream.

## DAY TO DAY USES

– You can use as a general purpose loose absorbent on most liquids or you can even use it to help remove hydrocarbon spills off water. After containing the spill with booms just sprinkle Absorbganic onto the spill and clean up as normal. The contaminated waste is disposed of in accordance with your local authority regulations.

For further advice or to arrange a no obligation demonstration just call us on **01506 430 309**



## 3 SIMPLE STEP REMEDY



## ABSORBGANIC LOOSE ORGANIC ABSORBENT

All our prices include delivery to a mainland UK address

**MODEL**  
AG10

**WEIGHT**  
10kg per bag  
35 bags per pallet

**ABSORBENCY**  
70ltr per 10kg bag

**DELIVERED PRICE**  
£27.00  
POA

# ABSORBENTS

## FLEETKLEEN™ & SPILLAWAY+™

### LIQUID & POWDER CLEANING PRODUCTS

The smart and easy way to keep your facility clean and slip free.

To order please contact us on **01506 430309**/[www.empteezy.co.uk](http://www.empteezy.co.uk)

#### FLEETKLEEN™

- For cleaning & degreasing in the workplace FleetKleen™ is a universal cleaner/degreaser that can be used to cleanse all solid surfaces
- It has the benefit of being dilutable at up to 150:1 with water
- It can be used through all cleaning media including scrubber/dryers, steam cleaners and pressure washers
- It will remove 100% of residues
- It will leave all surfaces completely slip free and skid resistant, greatly improving health and safety in the workplace
- FleetKleen™ is completely non-harmful and requires no special handling equipment or training.



#### HOW TO USE

##### PRESSURE WASHER PROCEDURE:

- Insert the mixing tube of the pressure washer directly into the spout of the container. This product must be mixed at a minimum of 15 parts water to 1 part FleetKleen™
- Adjust concentration levels as appropriate
- Apply the mixture directly on the area you wish to clean and degrease
- Use the "pressure" to aerate and agitate "stubborn" areas
- Allow the area to remain wet for as long as possible
- Very old stains may need several applications.

##### MANUAL SPRAYER & BRUSH PROCEDURE:

- Pre-mix FleetKleen™ in a sprayer at an appropriate concentration level
- This product must be mixed at a minimum of 15 parts water to 1 part FleetKleen™
- Spray the stained area with the mixture
- Wait a few minutes before proceeding
- Agitate and aerate the area with a stiff brush or broom
- Allow the area to remain wet for as long as possible
- Very old stains may need several applications.



#### SPILLAWAY+™

- An absorbent powder unlike others as it actually creates a physical bond with contaminants locking them into its structure
- It can be used to absorb all petroleum hydrocarbons and it will not leach
- It will leave all surfaces completely and immediately slip free and skid resistant
- It can be re-used between 5 to 10 times before disposal is necessary
- It's the perfect solution to both small and large spills of oil, grease, diesel, petrol, glycol, solvents and much more.

#### HOW TO USE

- If for use on a fresh spill, use just enough around the spill perimeter to create a barrier
- Now apply liberally to the spill itself so it covers the surface. When the oil has been absorbed by the powder (it turns dark grey) sweep it up and place in a spare container so you can re-use at a later time. SpillAway+™ may be reused until it will no longer absorb.

#### PLEASE NOTE:

1. Multiple use of SPILLAWAY+™ can reduce your Hazardous Waste disposal by up to 90%
2. FLEETKLEEN™ bio-remediates in situ, saving you disposal costs
3. With an average dilution rate of 50:1 FLEETKLEEN™ is highly effective and only costs you pence per litre to use

#### FLEETKLEEN™

MODEL	DESCRIPTION
FK1	1ltr container
FK20	2 x 10ltr containers
FK200	200ltr drum
FK1000	1000ltr IBC

All our prices include delivery to a mainland UK address

DELIVERED PRICE
£23.00
£145.00
£1263.00
£6030.00

#### SPILLAWAY+™

MODEL	DESCRIPTION
SA12	12kg pail
SA24	24kg bag

All our prices include delivery to a mainland UK address

DELIVERED PRICE
£70.00
£123.00

# ABSORBENTS

## MICROTEX® BLUE ECOLINE & MULTILINE INDUSTRIAL WIPES

Two melt-blown polypropylene lines compatible with most applications and liquids from acids & solvents to hydrocarbons and derivatives, cutting oil, paint, brake fluid, refrigerants and inks.

For advice on wipes please contact us on **01506 430309/advice@empteezy.co.uk**

### ECOLINE

- A single layer product suitable for wiping and absorbing
- Absorbs up to nine times its own weight.

### MULTILINE

- A triple layer product which is more durable and absorbent
- Absorbs up to nine times its own weight.

### APPLICATIONS

- Clean hands
- Wipe down components and tools
- Aerospace, Coach building, Electronics, Automotive, Printing etc.
- Available in "Z" fold packs, centre pull or standard roll format.



E75P



M85R



RHW



E75R



E75C

### INDUSTRIAL WIPES

All our prices include delivery to a mainland UK address

MODEL	SIZE	QTY & ABSORBENCY	DELIVERED PRICE
E75R	32cm x 38cm	500 wipes on a roll (4.6kg)	£48.00
E75C	26.5cm x 35cm	370 wipes on a centre feed roll in a dispensing box (2.3kg)	£26.00
E75P	32cm x 40cm	16 poly wraps with 40 Z-folded wipes in each (6.3kg) 640 total	£74.00
M85R	32cm x 38cm	500 wipes on 1 roll (6.5kg)	£56.00
M85C	26.5cm x 35cm	300 wipes on a centre feed roll in a dispenser box (3.4kg)	£36.00
<b>ROLL HOLDERS</b>			
RHW	640 x 560 x 570mm high	worktop dispenser unit	£87.00



# SPILL KITS



# BEST BUYS

If you have limited space in your department or vehicle then take a look at our CLEAR BAG KITS which have been designed to be un-obtrusive but still allow you to deal with minor leaks and spills - SEE PAGE 29 for MAINTENANCE, OIL SELECTIVE & CHEMICAL versions from as little as £24.00



Unique to Empteezy, our highly versatile lightweight container kit gives you 63ltr of absorbency in a secure fully mobile container – SEE PAGE 30 for this great kit. Prices from £109.00



For major incident response our MAXI KIT is fitted with fork pockets and wheels for easy movement and is available in MAINTENANCE, OIL SELECTIVE & CHEMICAL versions. 384ltr absorbency and prices from £484.00 – SEE PAGE 32



Due to the volatile nature of both fuel and steel prices Empteezy reserves the right to amend the prices shown in this catalogue without notice. Note: All prices shown include delivery to a mainland UK address.



# SPILL KITS (S.K.C.) SPILL KIT CARE PROGRAMME

For advice on spill control please contact us on [01506 430309](tel:01506430309)/[advice@empteezy.co.uk](mailto:advice@empteezy.co.uk)

– **Extract from section 7 of the Pollution Prevention Guideline PPG26: Storage & Handling of drums and intermediate bulk containers:**

- Spill kits containing materials such as leak-sealing putty, over-drums, drain seals, oil or chemical absorbents and personal protective equipment (PPE) should be on site. These should be located both within or near the storage area and remote from it (in case during an event it is not possible to reach the equipment near the storage containers)
- All staff should be trained in the use of this equipment. Consider providing a 'quarantine area' where leaking containers can be placed safely. It is advisable to have a leak-sealing kit available at delivery and handling areas or other high-risk locations to seal leaking drums temporarily. It is also recommended that vehicles transporting drums and IBC's carry a spill kit.

## HOW WE CAN HELP

- The selection and location of the appropriate Spill Kits for the individual applications on your site is in our opinion as important as the correct selection and location of Fire Extinguishers and/or First Aid Kits. None of us would dream of second guessing which type of Fire Extinguisher or First Aid Kit we require, nor ignore the training of the appropriate staff in their use
- One of the most common issues we encounter when visiting companies who already have kits in place is neglect. Unless someone is regularly checking the contents and condition of the kits, guess what, when there is a requirement to use a kit there is a good chance it will be depleted or empty. This is a time consuming job that is easy to push down a list of priorities but that can and will lead to problems if not carried out regularly
- Empteezy's S.K.C. programme not only carries out the selection and positioning of the kits for you, it provides training for staff to familiarise them with the contents of the kits and how to best use them, based on our 8 Steps to Spill Response Guide. To further help with this or if you are accredited to, or working towards ISO 14001 we offer spill kit location maps, spill kit content forms and spill kit contents replenishment forms
- As part of the care programme we can monitor the condition and "readiness for use" of your kits using the forms and one of our fully trained members of staff who will attend your site on agreed dates to ensure your kits are:
  - Fully stocked READY FOR USE
  - In a good state of repair READY FOR USE
  - In the right location READY FOR USE.

## CONTACT US

- Why not contact us today on 01506 430309 to arrange a "no obligation" site assessment to ascertain your individual requirements and help you to create a responsible, safe and effective emergency spill programme.



# SPILL KITS

To order please contact us on **01506 430309**/[www.empteezy.co.uk](http://www.empteezy.co.uk)

- When choosing your spill kit(s) there are some basic questions that need addressing to ensure that you get the correct kit(s) for your facilities.

## WHAT IS THE LIQUID?

- How much liquid is there? (Volume)
- Where is the liquid stored and in what type and size of containers?
- Would any spill be indoors or outdoors?
- Are there surface water drains in the vicinity?
- Could a spill access any water? (Drains, culverts, boreholes, rivers etc.)
- Could a spill cause ground contamination?
- Are there any access restrictions to the spill area?

## WHAT SIZE OF KIT(S) DO YOU NEED?

- You don't need a kit the same size as the total capacity of the container(s) you have, you need to understand the actual risk, and the time it might reasonably take to stop the flow (turn off a tap, roll a drum hole side up, plug a hole with plugging compound) this will give you a good indication of the amount of liquid you have to contain and absorb and help determine the size of kit required.

## EXAMPLE 1

- A 205ltr drum that has been spiked by a forklift truck does not need a 205ltr capacity kit because you should be able to roll the drum damage side up to stop the flow while you seal it. In practical terms you may have lost anything from 20ltr to 60ltr so with that in mind and some lea-way built in, you would need a kit with around 80ltr to 100ltr capacity.

## EXAMPLE 2

- In a production area you have a tank with a capacity of 10,000ltr and it feeds a machine at a rate of 10ltr per min. If the feed pipe from the tank burst, you will not need a 10,000ltr kit because you would either turn off the supply from the tank or "bandage" the pipe to stem the flow. This might take around 10 minutes to achieve so you could be faced with a circa 100ltr spill, as before if we build in room for error we would suggest a kit of around 200ltr capacity
- Which version of kit should you use? (These are only examples; if you are unsure please contact us for guidance).

## MAINTENANCE KIT

- Use with: Fuel Oil, Diesel, Petrol, Coolant, Cutting Fluid, Hydraulic Oil, Vegetable Oil, Acetone, Turpentine, Ether, MEK, Hexane, Trichloroethylene and any Water based liquids.

## OIL SELECTIVE KITS

- Use with: All derivatives of Hydrocarbons including Fuel Oil, Petrol, Diesel, Motor Oil, Jet Fuel Kerosene, Hydraulic Oil and Vegetable Oil in any application where you don't want to absorb WATER.

## CHEMICAL KITS

- Typical examples: Caustic Soda, Hydrochloric Acid, Sulphuric Acid, Sodium Hydroxide, Nitric Acid and Water. In fact they are ideal with almost any liquid, making them ideal when you are unsure what the liquid is
- A complete survey of your facility will answer these questions, allowing you to choose the correct size and type of kit(s). We are happy to carry out this work on your behalf, an 'outside' pair of eyes will often pick up on areas you 'walk past' every day and possibly take for granted.

## SPILL RESPONSE – AN 8 STEP GUIDE

- **1 ASSESS** As soon as you encounter a spill and until it has been successfully dealt with, you must constantly assess the risk it poses to personnel, the environment and property. **SAFETY ALWAYS COMES FIRST.** Try and determine what the liquid is, the quantity involved and if there are any casualties. **NEVER** try to deal with the spill on your own, inform colleagues and wait until at least one other person is in attendance. Remember to replenish all your absorbents kits and back up stock along with disposed of PPE drain blockers etc.
- **2 PROTECT** Always wear the appropriate P.P.E. (personal protection equipment) to allow you to safely respond to the spill. Check M.S.D.S. (material, safety data sheets) for the hazards associated with the liquid spilled and then dress accordingly. **IF IN DOUBT, ASSUME THE WORST AND WEAR THE HIGHEST LEVEL OF P.P.E.**
- **3 CONTAIN** By containing the spill you buy time. You should also reduce the area of contamination and lessen the impact the spill will have. Use absorbent seals and booms or poly booms to provide a fast, effective containment barrier.
- **4 STOP THE SPILL** Once the spill is contained; **STOP** the source of the spill. Roll a drum damaged side up, turn a tap off, plug a hole etc. If appropriate decant any remaining liquid into a vessel. Remember **NEVER** step in the spill.
- **5 RE-ASSESS** After the spill has been contained and the source controlled, re-assess the entire situation before starting clean-up. Ensure that the spill is fully under control.
- **6 CLEAN-UP** This can be as simple as wiping up with absorbent pads or using a cushion on deeper spills. Treat all contaminated material as the liquid spilled and dispose of accordingly.
- **7 DECONTAMINATION** Ensure all the personnel involved with the spill are fully decontaminated. The site of the spill, all P.P.E. & equipment must also be fully decontaminated and checked. If items have been damaged or cannot be fully decontaminated, dispose of accordingly and replace with new.
- **8 REPORT & REPLENISH** Compile a complete report of the incident and fill out all associated paperwork. De-brief all personnel involved and learn from the experience. If needs be, change your procedures and/or the location of some or all of your spill kits. You will be better prepared should there be a next time. Remember to replenish all your Spill Kits and back-up stocks along with disposed of P.P.E., Drain Blockers etc.

# SPILL KITS

## VEHICLE SPILL KITS

### RIGID & ARTICULATED VEHICLE SPILL KITS

Two types of kit available in Chemical and Oil Selective formats providing cover against hazardous and non-hazardous spills.

For advice on spill control please contact us on **01506 430309/advice@empzeezy.co.uk**



#### VEHICLE KITS

- Remember it's not just the load, it could be the vehicle itself
- Contain spills from ruptured fuel lines or brake fluid
- Spill Kit refills are available, please contact us for details.

#### TSO2, TSC2

- Contents:
  - 25 pads 40cm x 50cm,
  - 3 socks 7.5cm x 1.2m,
  - 1 x 500g tub plugging compound,
  - 2 disposal bags/ties,
  - 1 x gloves, 1 x goggles
- Absorbs: 27ltr.

#### TSO3, TSC3

- Contents:
  - 25 pads 40cm x 50cm,
  - 4 socks 7.5cm x 1.2m
  - 2 cushions 40cm x 40cm,
  - 1 x 500g tub plugging compound,
  - 4 disposal bags/ties,
  - 1 x gloves, 1 x goggles
- Absorbs: 45ltr.



It is the user's responsibility to check the compatibility of the gloves and goggles supplied in each kit against the liquid spilled prior to use.

Add  
Fleetkleen™ to your  
Oil Selective spill kit,  
it's the natural way to  
decontaminate surfaces  
after a hydrocarbon  
spill. See FK1  
page 22.

#### VEHICLE SPILL KITS

All our prices include delivery to a mainland UK address

MODEL	TYPE	CONTAINER TYPE	CONTAINER SIZE	ABSORBS	DELIVERED PRICE
TSO2	Oil Selective	Plastic box with fixing frame	750 x 320 x 280mm	27ltr	£135.00
TSC2	Chemical	Plastic box with fixing frame	750 x 320 x 280mm	27ltr	£154.00
TSO3	Oil Selective	Plastic box with fixing points	590 x 400 x 430mm	45ltr	£176.00
TSC3	Chemical	Plastic box with fixing points	590 x 400 x 430mm	45ltr	£215.00

# SPILL KITS

## COMPACT CLEAR BAG SPILL KITS

## GRAB BAG SPILL KITS

Maintenance, Oil Selective and Chemical formats available.

To order please contact us on **01506 430309**/[www.empteezy.co.uk](http://www.empteezy.co.uk)

### COMPACT CLEAR BAG KITS

- Ideal for labs/test facilities or any area where space is at a premium
- Stow one away in your car, van or truck
- Economical, fast and easy to use.

#### CBGP1, CBO1, CBC1

- Contents: 20 pads 30cm x 30cm, 1 thick pad 30cm x 30cm, 5 wipes, 1 disposal bag, 1 x gloves
- Absorbs: 11ltr.

#### CBGP2, CB02, CBC2

- Contents: 32 pads 30cm x 30cm, 1 sock 7cm x 1.2m, 5 wipes, 2 disposal bags, 1 x gloves
- Absorbs: 20ltr.

#### CBGP3, CB03, CBC3

- Contents: 35 pads 40cm x 50cm, 3 socks 7cm x 1.2m, 10 wipes, 2 disposal bags, 1 x gloves
- Absorbs 50ltr.

### GRAB BAG KITS

- Ideal for areas where it's easier to carry the kit than wheel it
- Keep one in your vehicle to comply with many companies access to site policies
- Comes complete with sealing putty and basic PPE (gloves & goggles)
- Spill Kit refills are available, please contact us for details.

#### TSGP1, TSO1, TSC1

- Contents: 25 pads 40cm x 50cm, 3 socks 7.5cm x 1.2m, 1 x 500g tub plugging compound, 2 disposal bags/ties, 1 x gloves, 1 x goggles
- Absorbs: 27ltr.

#### SKGP1, SKO1, SKC1

- Contents: 50 pads 40cm x 50cm, 4 socks 7.5cm x 1.2m, 1 cushion 40cm x 40cm, 1 x 500g tub plugging compound, 2 disposal bags/ties, 1 x gloves, 1 x goggles.
- Absorbs: 53ltr.

It is the user's responsibility to check the compatibility of the gloves and goggles supplied in each kit against the liquid spilled prior to use.



### CLEAR BAGS SPILL KITS

All our prices include delivery to a mainland UK address

MODEL	TYPE	CONTAINER TYPE	CONTAINER SIZE	ABSORBS	DELIVERED PRICE
CBGP1	Maintenance	Clear bag with zip	320 x 320 x 80mm high	11ltr	£24.00
CBGP2	Maintenance	Clear bag with zip	320 x 320 x 160mm high	20ltr	£40.00
CBGP3	Maintenance	Clear bag with zip	600 x 400 x 200mm high	50ltr	£75.00
CBO1	Oil Selective	Clear bag with zip	320 x 320 x 80mm high	11ltr	£25.00
CBO2	Oil Selective	Clear bag with zip	320 x 320 x 160mm high	20ltr	£42.00
CBO3	Oil Selective	Clear bag with zip	600 x 400 x 200mm high	50ltr	£58.00
CBC1	Chemical	Clear bag with zip	320 x 320 x 80mm high	11ltr	£27.00
CBC2	Chemical	Clear bag with zip	320 x 320 x 160mm high	20ltr	£50.00
CBC3	Chemical	Clear bag with zip	600 x 400 x 200 mm high	50ltr	£83.00

### GRAB BAGS SPILL KITS

All our prices include delivery to a mainland UK address

MODEL	TYPE	CONTAINER TYPE	CONTAINER SIZE	ABSORBS	DELIVERED PRICE
TSGP1	Maintenance	PVC grab bag	590 x 150 x 500mm high	27ltr	£66.00
TSO1	Oil Selective	PVC grab bag	590 x 150 x 500mm high	27ltr	£65.00
TSC1	Chemical	PVC grab bag	590 x 150 x 500mm high	27ltr	£73.00
SKGP1	Maintenance	PVC grab bag	590 x 250 x 500mm high	53ltr	£86.00
SKO1	Oil Selective	PVC grab bag	590 x 250 x 500mm high	53ltr	£82.00
SKC1	Chemical	PVC grab bag	590 x 250 x 500mm high	53ltr	£89.00

# SPILL KITS LIGHTWEIGHT CONTAINER SPILL KITS

One size in three formats, Maintenance, Oil Selective and Chemical.

For advice on spill control please contact us on **01506 430309/advice@emptezy.co.uk**



HINGED LID



REMOVABLE LID



**EXCLUSIVE  
NEW PRODUCT**

**HIGHLY VERSATILE**

**PRACTICAL  
FEATURES**

## SPILL DOCTOR KITS

- Make them an integral part of your site spill response equipment
- Lightweight and easy to use
- Fitted with two "tamper tag" security points to dissuade misuse
- Innovative lid can be completely removed or hinged open
- Concealed wheels & stow-away handle aid movement
- Spill Kit refills are available, please contact us for details.

## SKGP10, SKO10, SKC10

- Contents:  
25 pads 40cm x 50cm,  
5 socks 7.5cm x 1.2m,  
4 cushions 40cm x 40cm,  
1 x 500g tub plugging compound,  
4 disposal bags/ties,  
1 x gloves, 1 x goggles
- Absorbs: 63ltr.

It is the user's responsibility to check the compatibility of the gloves and goggles supplied in each kit against the liquid spilled prior to use.



TAMPER TAG



QUICK RELEASE LOCKS



STOWAWAY HANDLE



CONCEALED WHEELS

## LIGHTWEIGHT CONTAINER SPILL KITS

All our prices include delivery to a mainland UK address

MODEL	TYPE	CONTAINER TYPE	CONTAINER SIZE	ABSORBENCY	DELIVERED PRICE
SKGP10	Maintenance	Trolley	805 x 430 x 380mm	63ltr	£115.00
SKO10	Oil Selective	Trolley	805 x 430 x 380mm	63ltr	£109.00
SKC10	Chemical	Trolley	805 x 430 x 380mm	63ltr	£125.00

# SPILL KITS WHEELIE BIN & CART SPILL KITS

Available in Maintenance, Oil selective and Chemical formats.

To order please contact us on **01506 430309**/[www.empteezy.co.uk](http://www.empteezy.co.uk)

## WHEELIE BIN KITS

- Use in individual areas or as part of your overall site response program
- 2 sizes available
- Ideal for fuel delivery points
- Site one near your chemical dosing point
- Spill Kit refills are available, please contact us for details

### SKGP6, SKO6, SKC6

- Contents:  
50 pads 40cm x 50cm,  
4 socks 7.5cm x 1.2m,  
1 sock 7.5cm x 3m,  
4 cushions 40cm x 40cm,  
1 x 500g tub plugging compound,  
3 disposal bags/ties,  
1 x gloves, 1 x goggles
- Absorbs: 84ltr.

### SKGP7, SKO7, SKC7

- Contents:  
200 pads 40cm x 50cm,  
8 socks 7.5cm x 1.2m,  
3 socks 7.5cm x 3m,  
5 cushions 40cm x 40cm,  
1 x 500g tub plugging compound,  
10 disposal bags/ties,  
1 x gloves, 1 x goggles
- Absorbs: 218ltr.

## CART KITS

- Great for daily housekeeping on the shop floor
- Roll holder or worktop versions available
- Highly visible and manoeuvrable
- Spill Kit refills are available, please contact us for details.h

### CKGP1, CKO1, CKC1

- Contents:  
1 roll 40cm x 60m,  
10 socks 7.5cm x 1.2m,  
5 socks 7.5cm x 3m,  
5 cushions 40cm x 40cm,  
1 x 500g tub plugging compound,  
4 disposal bags/ties,  
1 x gloves, 1 x goggles
- Absorbs: 211ltr.

### CKGP2, CKO2, CKC2

- Contents:  
50 pads 40cm x 50cm,  
5 socks 7.5cm x 1.2m,  
5 socks 7.5cm x 3m,  
4 cushions 40cm x 40cm,  
1 x 500g tub plugging compound,  
4 disposal bags/ties  
1 x gloves, 1 x goggles
- Absorbs: 135ltr.

It is the user's responsibility to check the compatibility of the gloves and goggles supplied in each kit against the liquid spilled prior to use.



Add Fleetkleen™ to your Oil Selective spill kit, it's the natural way to decontaminate surfaces after a hydrocarbon spill. See FK1 page 22.



## WHEELIE BIN SPILL KITS

All our prices include delivery to a mainland UK address

MODEL	TYPE	CONTAINER TYPE	CONTAINER SIZE	ABSORBS	DELIVERED PRICE
SKGP6	Maintenance	Wheeled Container	460 x 480 x 920mm high	84ltr	£142.00
SKO6	Oil Selective	Wheeled Container	460 x 480 x 920mm high	84ltr	£148.00
SKC6	Chemical	Wheeled Container	460 x 480 x 920mm high	84ltr	£165.00
SKGP7	Maintenance	Wheeled Container	580 x 650 x 1040mm high	218ltr	£253.00
SKO7	Oil Selective	Wheeled Container	580 x 650 x 1040mm high	218ltr	£255.00
SKC7	Chemical	Wheeled Container	580 x 650 x 1040mm high	218ltr	£280.00

## CART SPILL KITS

All our prices include delivery to a mainland UK address

MODEL	TYPE	CONTAINER TYPE	CONTAINER SIZE	ABSORBS	DELIVERED PRICE
CKGP1	Maintenance	Mobile Cupboard	650 x 725 x 1460mm high	211ltr	£456.00
CKO1	Oil Selective	Mobile Cupboard	650 x 725 x 1460mm high	211ltr	£472.00
CKC1	Chemical	Mobile Cupboard	650 x 725 x 1460mm high	211ltr	£512.00
CKGP2	Maintenance	Mobile Cupboard	640 x 725 x 1025mm high	135ltr	£358.00
CKO2	Oil Selective	Mobile Cupboard	640 x 725 x 1025mm high	135ltr	£395.00
CKC2	Chemical	Mobile Cupboard	640 x 725 x 1025mm high	135ltr	£447.00

# SPILL KITS INTERMEDIATE & MAXI SPILL KITS

Each type is available in three formats, Maintenance, Oil Selective and Chemical.

For advice on spill control please contact us on **01506 430309/advice@empteezy.co.uk**

Add Fleetkleen™ to your Oil Selective spill kit, it's the natural way to decontaminate surfaces after a hydrocarbon spill. See FK1 page 22.



## INTERMEDIATE SPILL KITS

- Locate them around your site for rapid response to any incident
- Keep an oil selective kit near your site outfall to protect adjacent waterways
- Ideal for your goods in/out storage point
- Spill Kit refills are available, please contact us for details.

## SKGP9, SKO9, SKC9

- Contents:  
100 pads 40cm x 50cm,  
6 socks 7.5cm x 1.2m,  
4 socks 7.5cm x 3m,  
4 cushions 40cm x 40cm,  
1 x 500g tub of plugging compound,  
5 disposal bags/ties  
1 x gloves, 1 x goggles
- Absorbs: 153ltr.

## MAXI SPILL KITS

- Ideal when you have quantities of drums/IBC's on site
- Although fitted with wheels this kit has folk pockets to aid movement
- Makes a great "back-up" kit to other areas on site
- Spill Kit refills are available, please contact us for details.

## SKGP4, SKO4, SKC4

- Contents:  
300 pads 40cm x 50cm,  
10 socks 7.5cm x 1.2m,  
5 socks 7.5cm x 3m,  
2 booms 13cm x 3m,  
6 cushions 40cm x 40cm,  
1 x 500g tub plugging compound,  
20 disposal bags/ties,  
1 x gloves, 1 x goggles
- Absorbs: 384ltr.

It is the user's responsibility to check the compatibility of the gloves and goggles supplied in each kit against the liquid spilled prior to use.

### INTERMEDIATE SPILL KITS

All our prices include delivery to a mainland UK address

MODEL	TYPE	CONTAINER TYPE	CONTAINER SIZE	ABSORBS	DELIVERED PRICE
SKGP9	Maintenance	Wheeled Container	842 x 602 x 660mm high	153ltr	£245.00
SKO9	Oil Selective	Wheeled Container	842 x 602 x 660mm high	153ltr	£235.00
SKC9	Chemical	Wheeled Container	842 x 602 x 660mm high	153ltr	£280.00

### MAXI SPILL KITS

All our prices include delivery to a mainland UK address

MODEL	TYPE	CONTAINER TYPE	CONTAINER SIZE	ABSORBS	DELIVERED PRICE
SKGP4	Maintenance	Wheeled Container	1265 x 855 x 910mm high	384ltr	£484.00
SKO4	Oil Selective	Wheeled Container	1265 x 855 x 910mm high	384ltr	£509.00
SKC4	Chemical	Wheeled Container	1265 x 855 x 910mm high	384ltr	£560.00

# SPILL KITS

## CUPBOARD SPILL KITS

### SPILL STATION SIGN, BAGS/TIES & SECURITY TAGS

Equipment for your spill response programme.

To order please contact us on **01506 430309**/[www.empteezy.co.uk](http://www.empteezy.co.uk)

#### CUPBOARD SPILL KITS

- Place one in a strategic position on the shop floor to give staff daily access to absorbents for housekeeping
- Double lock to control access
- Spill Kit refills are available, please contact us for details.

#### SKGP8, SKO8, SKC8

- Contents:
  - 250 pads 40cm x 50cm,
  - 10 socks 7.5cm x 1.2m,
  - 10 socks 7.5cm x 3m,
  - 4 booms 13cm x 3m,
  - 10 cushions 40cm x 40cm,
  - 2 x 500g tubs
- plugging compound,
- 20 disposal bags/ties,
- 2 x gloves, 2 x goggles
- Absorbs: 511ltr.



BAG/TIE 10



SKSS



SKGP8

#### BAGS AND TIES

- Dispose of your used absorbents in the correct manner
- Treat the used absorbent as the liquid absorbed
- Remember to "tag" the bags stating what the liquid is that has been absorbed.

#### SPILL KIT STATION WALL SIGN

- Highlight where your spill kits are located
- Remember to include locations on your site response plan
- Quickly identifies where your spill kits are located to external agencies attending an incident.

#### SECURITY TAGS SPILL KIT SECURITY SEAL

- The easy way to know if your spill kit has been used or tampered with.



SKS



#### CUPBOARD SPILL KITS

All our prices include delivery to a mainland UK address

MODEL	TYPE	CONTAINER TYPE	CONTAINER SIZE	ABSORBS	DELIVERED PRICE
SKGP8	Maintenance	Static Cupboard	920 x 720 x 1520mm high	511ltr	£826.00
SKO8	Oil Selective	Static Cupboard	920 x 720 x 1520mm high	511ltr	£831.00
SKC8	Chemical	Static Cupboard	920 x 720 x 1520mm high	511ltr	£975.00

#### SPILL STATION SIGN, BAGS/TIES & SECURITY TAGS

All our prices include delivery to a mainland UK address

MODEL	DESCRIPTION	DELIVERED PRICE
SKS	Spill Station Sign 300 x 250mm	£19.00
BAG/TIE10	10 yellow disposal bags & 10 ties. Marked 'Waste' or 'Hazardous Waste Handle with care'. Please specify with order	£23.00
SKSS	10 Spill Kit Security Seals	£5.00



# SPILL KITS

## STATIC BIN & OPA 90 SPILL KITS

### DURABLE RESPONSE KITS FOR BIG SPILLS

These kits should be placed strategically to form the backbone of your sites spill response program.

For advice on spill control please contact us on [01506 430309](tel:01506430309)/[advice@empzeezy.co.uk](mailto:advice@empzeezy.co.uk)



SKGP11

Add  
Fleetkleen™ to your  
Oil Selective spill kit,  
it's the natural way to  
decontaminate surfaces  
after a hydrocarbon  
spill. See FK1  
page 22.



SKOPA90

#### **SKGP11, SKO11, SKC11**

- Contents:
  - 200 pads 40cm x 50cm,
  - 6 socks 7.5cm x 1.2m,
  - 4 socks 7.5cm x 3m,
  - 8 cushions 40cm x 40cm,
  - 1 x 500g tubs plugging compound,
  - 5 disposal bags/ties,
  - 1 x gloves, 1 x goggles
- Absorbs: 241ltr.

#### **SKOPA90**

- Contents:
  - 600 pads 40cm x 50cm,
  - 40 socks 7.5cm x 1.2m,
  - 16 socks 7.5cm x 3m,
  - 4 booms 13cm x 3m,
  - 15 cushions 30cm x 60cm,
  - 2 x 500g tubs plugging compound,
  - 20 disposal bags/ties,
  - 2 x gloves, 2 x goggles
- Absorbs: 1102ltr.
- SKOPA90 has been developed as a marine oil spill response kit designed to be deployed easily and effectively, in conjunction with each ships response plan, as required by the IMO and OPA 90
- The requirement of OPA 90 is that tankers 400ft or greater in length which are carrying oil in bulk shall have equipment to handle 12 barrels (1900ltr) of deck spill. Tankers under 400ft must be equipped to deal with 7 barrels (1100ltr), while in-land oil barges must be able to deal with at least 1 barrel.

It is the user's responsibility to check the compatibility of the gloves and goggles supplied in each kit against the liquid spilled prior to use.

#### STATIC & OPA90 SPILL KITS

All our prices include delivery to a mainland UK address

MODEL	TYPE	CONTAINER TYPE	CONTAINER SIZE	ABSORBS	DELIVERED PRICE
SKGP11	Maintenance	Static with fork pockets	875 x 875 x 810mm	241ltr	£365.00
SKO11	Oil Selective	Static with fork pockets	875 x 875 x 810mm	241ltr	£355.00
SKC11	Chemical	Static with fork pockets	875 x 875 x 810mm	241ltr	£400.00
SKOPA90	Oil Selective	Static with fork pockets	1460 x 1010 x 975mm	1102ltr	£1102.00

# SPILL KITS BODY FLUIDS ABSORBENTS & FRAGRANCED DISINFECTANT

The absorbent and disinfectant are non toxic, non bleaching, non corrosive and will kill a range of bacteria, spores, viruses and fungi. Please call us for further details.

To order please contact us on **01506 430309**/[www.empteezy.co.uk](http://www.empteezy.co.uk)

These kits contain super absorbent granules, disinfectant and blue PPE (easy to ID and compatible in food areas) including nitrile gloves.

Why super absorbent granules? They are less dusty than powder and they crystallize making them safer to use and easier to manage.

Formula 429 Plus disinfectant (fragranced) was winner of the Smart Solutions **NHS** project for controlling Healthcare Associated Infections.

## B1APP

- Contents: 1 carry case, 1 fragranced disinfectant spray (30ml), 1 super absorbent granules (10g), 1 clean-up pack.

## B1REF (REFIL)

- Contents: 1 clear grip seal bag, 1 fragranced disinfectant spray (30ml), 1 super absorbent granules (10g), 1 clean-up pack.

## B2APP

- Contents: 1 carry case, 2 fragranced disinfectant sprays (30ml), 2 super absorbent granules (10g), 2 clean-up packs.

## B5APP

- Contents: 1 carry case, 5 fragranced disinfectant sprays (30ml), 5 super absorbent granules (10g), 5 clean-up packs.

## SUPER ABSORBENT GRANULES WITH DEODORISER

- G10GD: 10g sachet
- G100GD: 100g in a bottle with shaker top
- G500GD: 500g in a bottle with shaker top

## CLEAN UP PACK

- Contents: 1 clear grip seal bag, 1 pair blue nitrile gloves, 1 pair blue polythene over-sleeves, 1 blue polythene apron, 1 pair blue overshoes, 1 set polypropylene scraper & scoop, 1 Biohazard self-seal bag, 2 absorbent viscose wipes (blue), 1 cleansing wipe, 1 set of instructions.

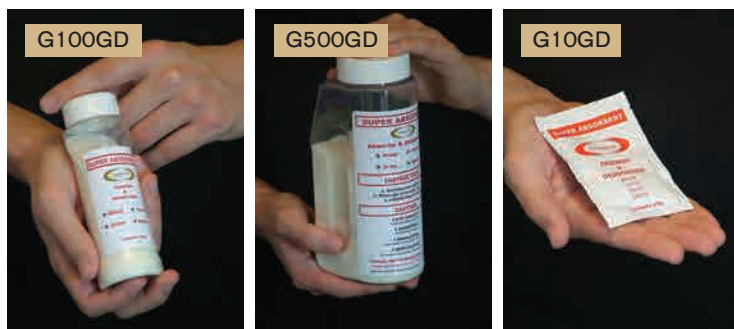

Ex-works prices all orders with a total value over £150 delivered FOC  
all orders under this value please call for a delivery price

## BODY FLUID ABSORBENTS

MODEL	DESCRIPTION	EX-WORKS PRICE
B1APP	1 x 30ml disinfectant, 1 x 10g super absorbent granules and 1 clean-up pack supplied in a carry case	£11.00
B1REF	1 x 30ml disinfectant, 1 x 10g super absorbent granules and 1 clean-up pack supplied in a clear grip seal bag	£5.00
B2APP	2 x 30ml disinfectant, 2 x 10g super absorbent granules and 2 clean-up packs supplied in a carry case	£16.00
B5APP	5 x 30ml disinfectant, 5 x 10g super absorbent granules and 5 clean-up packs supplied in a carry case	£45.00
G10GD	1 x 10g in a sachet	£1.00
G100GD	1 x 100g in a plastic bottle with a built-in shaker top	£9.00
G500GD	1 x 500g in a plastic bottle with a built-in shaker top	£38.00

# SPILL KITS

## SITE & VEHICLE TELESTOPPER™

### MANUALLY OPERATED DRAIN SEALER

Enables you to respond to spills and seal unprotected drains.

To order please contact us on **01506 430309**/[www.empteezy.co.uk](http://www.empteezy.co.uk)

#### TELESTOPPER™

- A valuable addition to your spill response equipment the Telestopper™ can be used as part of your site response or carried on your vehicles to allow drivers to limit the spread of a spill during a delivery or from their vehicle during transit.

#### WHEN USING WITH YOUR VEHICLE



##### STEP ONE

- Call the emergency services, put on your P.P.E and then if it is safe to do so, go to the nearest drain to the spill and deploy your Telestopper™ so you block the direction of the flow

##### STEP TWO

- Inflate the Telestopper™ bladder by connecting to the nearest vehicle tyre with the inflation hose or use the manual pump



##### STEP THREE

- Replace the drain cover & mark with a warning triangle or hazard sign. Retreat to a safe distance & await the emergency services.



#### WHEN USING ON YOUR SITE

##### STEP ONE

- Put the stirrup pump on a flat surface at a safe distance from the spill (maximum of 6m) lift the drain/manhole cover and insert the Telestopper™ firmly into the pipe blocking the outward flow

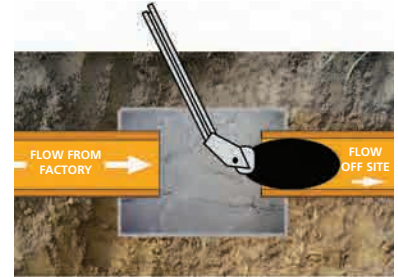

##### STEP TWO

- Return to the stirrup pump, stand with one foot on either side of the base and pump the handle up and down until resistance to pumping is felt (regulator set pressure has been reached). This action will inflate the bladder, locking it in place and ensuring any spill is contained on-site in the drain

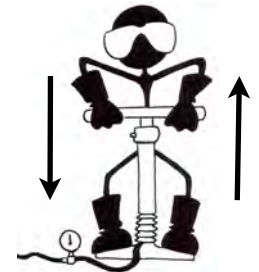

##### STEP THREE

- Replace the drain/manhole cover and place a warning sign or hazard barrier to warn staff. Any spill can now be extracted and disposed of accordingly. Remember to decontaminate /replace all equipment ready for future use.



NOTE: After the Telestopper™ has been inflated do not try to force the pump handle down as this may cause over inflation and do not tamper with the factory set regulator.

#### SITE & VEHICLE TELESTOPPER™

All our prices include delivery to a mainland UK address

MODEL	DESCRIPTION	DELIVERED PRICE
STS	1 x 1.2m extending to 3m pole 1 x stirrup pump with pre-set regulator & 5m air line 1 x 100mm to 300mm bladder with quick release system 1 x nylon carry bag	£400.00

# SPILL KITS FLAPSTOPPER™ DRAIN SEALING SYSTEM

The pollutant containment system with a patented 100% fail-safe locking mechanism.

For advice on spill control please contact us on [01506 430309](tel:01506430309)/[advice@empteezy.co.uk](mailto:advice@empteezy.co.uk)



A site survey is required before purchasing this product, it is as you would expect confidential, free of charge and without any onus on you to purchase anything. Please contact us so we can get an area manager to make an appointment to come and see you.

**PRICES AVAILABLE ON APPLICATION**

1. In the unlocked position Flapstopper™ freely allows water to flow in an outward direction, but will close in the event of a reverse flow.

2. In the event of a spill or fire Flapstopper™ closes and locks to seal the drain, this is activated by an automatic sensor or a manual panic button, it will even remain closed in the event of a power failure.

3. In the locked mode the Flapstopper™ will ensure that the pollutant is safely contained within the drain, buying you time to deal with the spill and have the drain "sucked out." Once clear the system can be re-set to allow normal flow.

**Unlike inflatable bladder systems Flapstopper™ can be activated as often as required without complicated resetting procedures.**

# SPILL KITS REUSABLE, ONE TIME USE & CUSTOM FIT DRAIN COVERS

Stops spills accessing drainage systems.

For advice on spill control please contact us on **01506 430309/advice@empzeezy.co.uk**



STS010

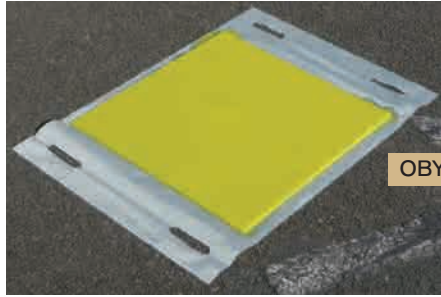

OBY061



## RE-USABLE DRAIN COVERS

- Manufactured from polyurethane these mats have a naturally sticky finish to one side which provides a mechanical grip to the surface they are used on
- After use it is advisable to clean any particles that may have adhered to them (mild soap solution, but don't wipe with a cloth as fibres will stick to the mat)
- When selecting a mat always try and oversize by a minimum of 100mm to ensure a positive seal.



4000X



4780



4030X

## ONE TIME USE DRAIN COVERS

- Simple to use:
  1. Remove outer packaging
  2. Remove bottom layer to expose mat
  3. Press down onto drain surface
  4. Remove top layer and its ready
- You can "knit" more than one mat together to deal with oversized drains
- After use treat as the liquid that it came into contact with and dispose of accordingly.

## WALL BOX FOR DAMMIT MAT

- Galvanised steel
- Can hold 2 large Dammit mats.

## CUSTOM MADE DRAIN COVER

- Designed specifically to fit individual drains
- Simply clamp in place
- The ideal choice when you are repeatedly using a drain cover pro-actively during deliveries
- Stainless steel construction means no rusting



CUSTOM DRAIN COVER



### REUSABLE DRAIN COVERS & CARRY BAGS

All our prices include delivery to a mainland UK address

MODEL	SIZE	WEIGHT	DELIVERED PRICE
OBY061	600 x 600 x 9mm	3.7kg	£164.00
OBY091	900 x 900 x 9mm	8.3kg	£256.00
OBY121	1200 x 1200 x 9mm	15kg	£399.00
STS010	Yellow & black carry bag for OBY061	n/a	£14.00
STS020	Yellow & black carry bag for OBY091 & OBY121	n/a	£16.00

### ONE TIME USE & CUSTOM DRAIN COVERS

All our prices include delivery to a mainland UK address

MODEL	SIZE	DELIVERED PRICE
4000X	2 x 45 x 65cm	£78.00
4010X	2 x 45 x 45cm	£68.00
4020X	12 x 20 x 22.5cm	£94.00
4030X	6 x 65 x 15cm	£112.00
4780 Wall Box Drain Cover	76 x 56 x 7.5cm	£164.00
	Custom made	POA

# SPILL KITS CONTAINMENT BOOMS & EQUIPMENT PERMANENT BOOMS

For areas where you need to deploy containment permanently, such as an outfall into a river.

For advice on spill control please contact us on [01506 430309](tel:01506430309)/[advice@empteezy.co.uk](mailto:advice@empteezy.co.uk)

## PERMANENT BOOMS

- Suitable for long term deployment these booms are robust and hard wearing and are available in two standard sizes with custom versions available on request
- Floatation is provided by rigid foam filled floats which are bolted to the skirt, the natural rigidity of the material helps the skirt stay upright in the water and ballast is provided by metal weights connected to the bottom edge
- Periodic maintenance is required to remove river or marine growth.



## PB300

- Freeboard: 100mm - Draft: 200mm
- Overall height: 300mm
- Section length: 15m
- Buoyancy to weight: 10:1
- Weight: 4.7kg per metre
- Fabric: NR rubber >5mm.



## PB600

- Freeboard: 200mm - Draft: 400mm
- Overall height: 600mm
- Section length: 15m
- Buoyancy to weight: 4:1
- Weight: 7.2kg per metre
- Fabric: NR rubber >5mm.

## NOTES

- Freeboard - Vertical height of product above the water
- Draft - Depth of product below the water.

## PRICES AVAILABLE ON APPLICATION



# SPILL KITS CONTAINMENT BOOMS & EQUIPMENT FENCE BOOMS

For inland or sheltered waters.

To order please contact us on **01506 430309**/[www.empteezy.co.uk](http://www.empteezy.co.uk)

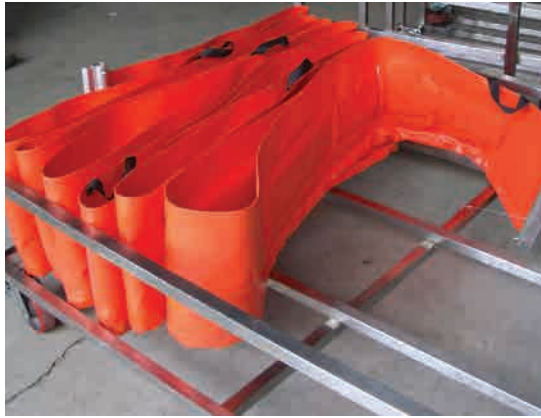

## FENCE BOOMS

- Lightweight and easy to use these booms are ideal for deploying from a reel and take up very little space when storing or transporting to a different location. Fence booms are not recommended for towing or sweeping at sea
- Available in 3 standard sizes with custom sizes available upon request.

### FB450

- Freeboard: 150mm
- Draft: 300mm
- Overall height: 450mm
- Section lengths: 10 or 25m
- Buoyancy to weight: 2:1
- Weight: 2kg per metre
- Packaging Volume: 0.35m<sup>3</sup> per 25m.

### FB650

- Freeboard: 250mm
- Draft: 400mm
- Overall height: 650mm
- Section lengths: 10 or 25m
- Buoyancy to weight: 2:1
- Weight: 2.8kg per metre
- Packaging Volume: 0.90m<sup>3</sup> per 25m.

### FB1000

- Freeboard: 350mm
- Draft: 650mm
- Overall height: 1000mm
- Section lengths: 10 or 25m
- Buoyancy to weight: 2:1
- Weight: 3.7kg per metre
- Packaging Volume: 1.20m<sup>3</sup> per 25m.



## PRICES AVAILABLE ON APPLICATION

# SPILL KITS CONTAINMENT BARRIERS & EQUIPMENT CURTAIN BOOMS

Curtain booms have a high buoyancy to weight ratio giving them a good response to waves.

For advice on spill control please contact us on **01506 430309/advice@empteezy.co.uk**

## **CURTAIN BOOMS**

- Available in 3 standard overall heights (250mm – 650mm – 900mm) this type of foam filled boom is typically used on inland or sheltered waters.

### **CB250**

- Freeboard: 100mm
- Draft: 150mm
- Overall height: 250mm
- Ballast 6mm hot dipped galvanized chain
- Packing Volume: 0.35m<sup>3</sup> /25m
- Weight: 3.2kg per metre.

### **CB650**

- Freeboard: 250mm
- Draft: 400mm
- Overall height: 650mm
- Ballast 12 mm hot dipped galvanized chain
- Packing Volume: 0.90m<sup>3</sup> /25m
- Weight: 7.8kg per metre.

### **CB900**

- Freeboard: 300mm
- Draft: 600mm
- Overall height: 900mm
- Ballast 16 mm hot dipped galvanized chain
- Packing Volume: 1.20m<sup>3</sup> /25m
- Weight: 9.0kg per metre.

## **ALL MODELS**

- Fabric: Orange or yellow 850gsm woven polyester scrim coated with PVC
- Section length: 10m or 25m
- Breaking Strength: ASTM D 5035 (Lengthwise & Widthwise: over 300kgf/5cm)
- Boom Connections: Extruded aluminium ASTM 962 (standard 1500kgf/5cm)
- Operational Temperature: 0 to +80°C
- Excellent UV Resistance
- Chemical Resistance: Acids, alkalis, solvents & hydrocarbons
- Buoyancy to weight: 6:1



## **NOTES**

- Freeboard - Vertical height of product above the water
- Draft - Depth of product below the water
- 300kgf/5cm - requires 300kg of force over a 5cm section before it will break
- We can manufacture different sizes of boom to meet your specific requirements and can offer different material types (PU and Neoprene) in different thickness finishes

**PRICES AVAILABLE ON APPLICATION**





# SPILL KITS CONTAINMENT BARRIERS & EQUIPMENT AIR BOOMS

Because they are very flat before being inflated they take up very little space and are ideal for deploying from spill response vessels.

To order please contact us on **01506 430309**/[www.empteezy.co.uk](http://www.empteezy.co.uk)



## AIR BOOMS

- Typically deployed from response vessels where a foam filled boom would be too bulky, the reduced volume of an air boom is also an asset when they have to be transported, possibly by air, to the spill site. Air booms are typically used in open waters where the high buoyancy to weight ratio assists the performance in the waves.

### AB650

- Freeboard: 250mm
- Draft: 400mm
- Overall height: 650mm
- Ballast 12mm hot dipped galvanized chain
- Packing Volume: 0.50m<sup>3</sup> /25m
- Weight: 2.8kg per metre.

### AB800

- Freeboard: 300mm
- Draft: 500mm
- Overall height: 800mm
- Ballast 12mm hot dip galvanized chain
- Packing Volume: 0.65m<sup>3</sup> /25m
- Weight: 3kg per metre.

### AB1200

- Freeboard: 500mm
- Draft: 700mm
- Overall height: 1200mm
- Ballast 16mm hot dip galvanized chain
- Packing Volume: 1.40m<sup>3</sup> /25m
- Weight: 6.2kg per metre.

## ALL MODELS

- Fabric: Orange or yellow 850gsm woven polyester scrim coated with PVC
- Section length: 10m or 25m
- Breaking Strength: ASTM D 5035 (Lengthwise & Widthwise: over 300kgf/5cm)
- Boom Connections: Extruded aluminium ASTM 962 (standard 1500kgf/5 cm)
- Operational Temperature: 0 to +80°C
- Excellent UV Resistance
- Chemical Resistance: Acids, alkalis, solvents & hydrocarbons
- Buoyancy to weight: 30:1

## NOTES

- Freeboard - Vertical height of product above the water
- Draft - Depth of product below the water
- 300kgf/5cm - requires 300kg of force over a 5cm section before it will break
- We can manufacture different sizes of booms to meet your specific requirements and can offer different material types (PU and Neoprene) in different thickness finishes

PRICES AVAILABLE ON APPLICATION

# SPILL KITS CONTAINMENT BARRIERS & EQUIPMENT BOOM REEL & BRUSH SKIMMER

By packing "flat" booms on a reel you save space and speed up deployment and recovery, while the brush skimmer removes contained spills.

For advice on spill control please contact us on [01506 430309](tel:01506430309)/[advice@empteezy.co.uk](mailto:advice@empteezy.co.uk)

## BOOM REEL

- Designed to store up to 250m of boom (1100mm height). The reel frame is manufactured in steel and the spool in marine grade aluminium and the unit comes complete with fork lift channels and 4-point lifting eyes to aid handling both on and offshore. For easy deployment and recovery of the boom, the reel has a hydraulic motor (requires a power-pack).



## BRUSH SKIMMER

- The skimmer head incorporates two side by side brush wheels covered with thousands of oleophilic (attract oils, repel water) bristles which rotate with the flow. The large surface area created by the bristles makes the unit very effective and as the wheels rotate the water flows away and the oil is scraped off into a collection hopper before being pumped to a recovery tank. Units can be configured for light or heavy oil and are available as small units for inland spills or large units for offshore applications. Powered by a hydraulic power pack the unit comes complete with all the necessary ancillary equipment. Please ensure the unit is connected to an effective suction pump.



PRICES AVAILABLE ON APPLICATION

# SPILL KITS CONTAINMENT BOOMS & EQUIPMENT FLOODSTOP FLOOD BARRIER

A practical and effective portable flood defence system that's fast to deploy and re-usable too.

To order please contact us on **01506 430309**/[www.empteezy.co.uk](http://www.empteezy.co.uk)

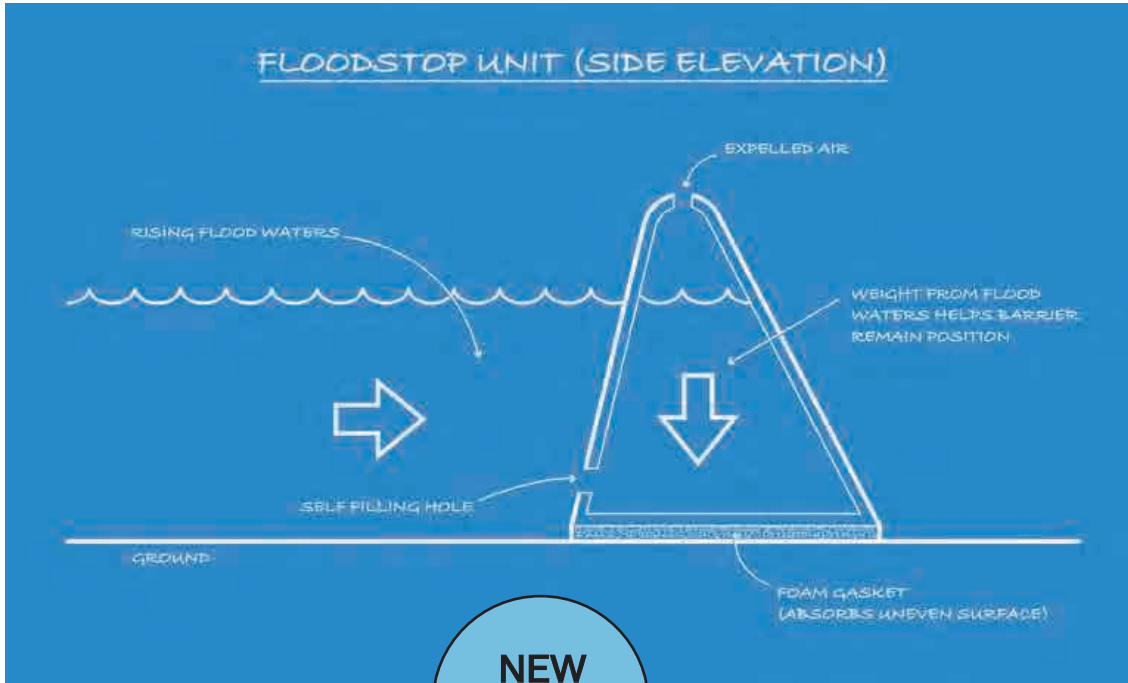

## FLOODSTOP

- If you had to construct a 30m long by 0.5m high flood wall from sandbags it would take one person 70 hours (filling, assembly and disposal afterwards) and remember sandbags are prone to significant leaks and breaching, can only be used once and require large amounts of manpower and time to deploy
- In comparison it would only take one person 30 minutes to deploy a 30m long by 0.5m high Floodstop barrier with an average cost savings of 19.3% the first time you use it, and subsequent deployments continuing to save you even greater amounts of resource and money
- Floodstop could not be easier or quicker to install, all the component parts comply with manual handling regulations which enables one person assembly. There is no construction work required and each section is connected to the next by a "plug-in" key that joins and seals the connection, while the multi-hub connector enables you to change the direction of the barrier and seal it to a wall
- Rotationally moulded using UV8 stabilised polymer to prevent UV degradation and 100% recyclable at end of life.

## SUITABLE TERRAIN

- Road pavements
- Pathways
- Concrete hard standings
- Grass or soil, depending on the undulations

## PRODUCT USES

- Demountable flood defence barrier
- Road traffic delineator
- Temporary containment system.

Ex-works prices please contact us for delivery cost

## FLOODSTOP FLOOD BARRIER

MODEL	DESCRIPTION	SIZE LxHxW	WEIGHT	EX-WORKS PRICE
FS500	1m section of barrier (12kg) complete with connection key (18kg)	1000 x 500 x 500mm	30kg	£210.00
FS500HUB	Connection hub for use with FS500	600 x 500 x 250mm	6kg	£130.00
FS900	1m section of barrier (22kg) complete with two part connection key (24kg each)	1000 x 900 x 750mm	70kg	£410.00
FS900HUB	Connection hub for use with FS900	740 x 900 x 400mm	12kg	£200.00

Standard Colours: Red or White

# SPILL KITS CONTAINMENT BOOMS & EQUIPMENT FLOODSTOP CONTAINMENT BARRIER

Temporary protection and containment system.

For advice on spill control please contact us on [01506 430309](tel:01506430309)/[advice@empteezy.co.uk](mailto:advice@empteezy.co.uk)

## FLOODSTOP

- How often do you have drums and IBC's arrive on site and for one reason or another you don't have the space or resource to put them straight away into your bunded stores?
- That scenario only needs to happen once for you to find yourself with a pollution incident on your hands. Unprotected product can easily be hit by a passing truck or fork lift truck causing a hazard to staff and the environment alike.
- Floodstop is the fast and simple way to provide a temporary, bunded area and highly visible collision protection too.



Ex-works prices please contact us for delivery cost

## FLOODSTOP CONTAINMENT BARRIER

MODEL	DESCRIPTION	SIZE LxHxW	WEIGHT	EX-WORKS PRICE
FS500	1m section of barrier (12kg) complete with connection key (18kg)	1000 x 500 x 500mm	30kg	£210.00
FS500HUB	Connection hub for use with FS500	600 x 500 x 250mm	6kg	£130.00
FS900	1m section of barrier (22kg) complete with two part connection key (24kg each)	1000 x 900 x 750mm	70kg	£410.00
FS900HUB	Connection hub for use with FS900	740 x 900 x 400mm	12kg	£200.00

Standard Colours: Red or White

# SPILL KITS

## LIQUID DIVERTER PLUGGING SYSTEMS

Control the flow of spilt liquids, plug holes and punctures caused by fork lift truck forks, etc.

For advice on spill control please contact us on **01506 430309/advice@empzeezy.co.uk**



### SPILL BARRIER

- Divert spilt liquid away from open drains or other sensitive areas
- Join multiple lengths together to protect a large area
- Simply decontaminate after use and stow away for future use.

### PLUGGING COMPOUND

- A "one time use" temporary repair product that enables you to seal holes quickly
- Wearing the PPE appropriate to the liquid leaking, open a tub of plugging compound, scoop out a quantity and "plug" the hole.

### CONICAL PLUGS

- Simply "force" the appropriate size plug into a hole to effect a temporary repair and stem the flow of liquid
- Can be decontaminated and reused
- The simple, fast and effective way of stopping leaking liquid in its tracks.



PLUGGING COMPOUND



### SPILL BARRIER

MODEL	SIZE	WEIGHT	DELIVERED PRICE
ORY010	10cm x 7cm x 3m	12kg	£339.00

All our prices include delivery to a mainland UK address

### PLUGGING COMPOUND

MODEL	SIZE	DELIVERED PRICE
4040X	12 x 800g tubs	£119.00
4050X	6 x 1.8kg tubs	£105.00
4037XU	18 x 500g tubs	£114.00

All our prices include delivery to a mainland UK address

### CONICAL PLUGS

MODEL	SIZE	WEIGHT	DELIVERED PRICE
OCY010	35mm – 70mmØ	0.5kg	£55.00
OCY020	60mm – 92mmØ	0.75kg	£65.00
OCY030	85mm – 120mmØ	1.2kg	£70.00
OCY040	120mm – 180mmØ	3kg	£139.00
OCY050	170mm – 230mmØ	6kg	£168.00

All our prices include delivery to a mainland UK address

# SPILL KITS

## MULTI-FUNCTION BUND

### PORTABLE CONTAINMENT

The effective way to contain leaks and spills or use for decontamination purposes

For advice on spill control please contact us on **01506 430309/advice@empteezy.co.uk**

## MULTI FUNCTION BUND

These portable bunds have a multitude of uses:

- As tarpaulin to protect a surface while work is carried out
- To capture leaks from vehicles
- As a reservoir for the short-term storage of liquids
- A temporary bund for drums and containers
- As a holding tank for oils etc. during a spill
- As a hazmat de-contamination pool.

## LINERS & PADS

- Liners provide additional protection when working with aggressive chemicals
- Pads give protection to the underside of the bund and reduce the risk of puncture.



BUND WITH OPTIONAL BUND LINER



## MULTI-FUNCTION BUND & ACCESSORIES

All our prices include delivery to a mainland UK address

MODEL	SIZE	DESCRIPTION	CAPACITY	DELIVERED PRICE
ET01	350 x 700 x 125mm	S - Bund 350 x 470 x 40mm when folded	25ltr	£109.00
ET11	340 x 690 x 125mm	S - Bund liner 350 x 470 x 20mm when folded	25ltr	£46.00
ET02	700 x 700 x 175mm	M - Bund 250 x 525 x 120mm when folded	75ltr	£169.00
ET12	690 x 690 x 175mm	M - Bund liner 250 x 525 x 20mm when folded	75ltr	£55.00
ET03	1000 x 1000 x 200mm	L - Bund 350 x 700 x 120mm when folded	175ltr	£209.00
ET13	990 x 990 x 200mm	L - Bund liner 350 x 700 x 20mm when folded	175ltr	£65.00
ET04	1500 x 1500 x 425mm	XL - Bund 500 x 1150 x 120mm when folded	900ltr	£409.00
ET14	1490 x 1490 x 425mm	XL - Bund liner 500 x 1150 x 20mm when folded	900ltr	£99.00
ET05	2000 x 2000 x 425mm	XXL - Bund 700 x 1500 x 120mm when folded	1600ltr	£549.00
ET15	1990 x 1990 x 425mm	XXL - Bund liner 700 x 1500 x 20mm when folded	1600ltr	£119.00
ET06	1240 x 840 x 225mm	Cargo Bund 280 x 850 x 120mm when folded	200ltr	£219.00
ET16	1230 x 830 x 225mm	Cargo Bund liner 280 x 850 x 20mm when folded	200ltr	£59.00
ET07	400 x 750 x 170mm	Carry bag for S, M & L Bunds		£36.00
ET08	750 x 1550 x 170mm	Carry bag for XL, XXL & Cargo Bunds		£49.00
ET09	1300 x 1300mm	Pad for use with S, M & L Bunds		£49.00
ET10	2200 x 2200mm	Pad for use with XL & XXL Bunds		£99.00



# DRUM & IBC STORAGE/ POLYETHELENE PRODUCTS



# BEST BUYS

---

For 205ltr drum storage try our low profile 4 drum spill pallet PP4L (blue) or PP4LY (yellow) which only costs £221.00 including delivery – SEE PAGE 53



If you use IBC's then our new range of IBC spill pallets is the most cost effective way of storing them in a compliant manner prices start from £490.00 including delivery to a mainland UK address – SEE PAGE 56



If lack of indoor storage space is an issue then our new hard covered spill pallet PP4HC might provide the solution. Access to the 4 x 205ltr storage area is via a light weight roller shutter door and the sump is fully compliant with UK regulations and priced at £985.00 – SEE PAGE 59



If you need to move drums around your facility and don't want the worry of it spilling then what you need is a PT10 fully contained trolley with a built-in 230ltr sump. Priced at £386.00 it's easy to use and designed for one person operation – SEE PAGE 65





# POLYETHYLENE - DRUM & IBC STORAGE PRODUCTS INTRODUCTION

For advice please contact us on **01506 430309** or e-mail **[advice@empteezy.co.uk](mailto:advice@empteezy.co.uk)**

- Using just one type of liquid as an example, here are some pointers as to why you should ensure your drums, IBC's and other containers are stored correctly.
- This guidance is relevant to any business; Industrial, Commercial, Institutional or the Armed Forces that store oil at their premises. Oil includes:
  - Petrol
  - Diesel
  - Central-heating oil
  - Lubricating oil
  - Mineral oil
  - Vegetable and plant oil
  - Heavy oils such as bitumen
  - Oils used as solvents, such as paraffin or kerosene
  - Waste oil.

## WHY YOU MUST STORE OIL CAREFULLY AND PREVENT POLLUTION:

- Oil accounts for over one quarter of all pollution incidents in the UK. Many drains lead directly to rivers, streams or lakes. Oil entering drains has the same effect as pouring it directly into the watercourse
- Oil is poisonous to fish and other wildlife and it smothers plant life too, just two litres of oil could seriously pollute the volume of fresh water needed to fill an Olympic-size swimming pool and make it undrinkable.

## AVOIDING PROSECUTION AND CLEAN-UP COSTS

- You may be prosecuted and fined if oil from your site enters the ground or watercourse, and you may have to pay substantial clean-up costs.

## CONTACT US

- Why not contact us today on 01506 430309 to arrange a "no obligation" site assessment to ascertain your individual requirements and help you to create a responsible, safe and effective emergency spill programme.



# POLYETHYLENE - DRUM & IBC STORAGE PRODUCTS

To order please contact us on **01506 430309**/[www.empteezy.co.uk](http://www.empteezy.co.uk)

## THE GOVERNMENT'S STANCE ON THE OIL STORAGE REGULATIONS

- The regulations apply minimum prescriptive standards on a blanket basis to all premises storing oil in above ground fixed or mobile tanks or facilities. This means that the Environment Agency (EA) will not need to make a special visit to individual sites to assess risks, but will enforce the regulations during routine visits and thus reduce resource burdens.

## BY USING THE RIGHT PRODUCTS FOR YOUR APPLICATIONS YOU WILL

- Contain leaking containers
- Improve safety by storing liquids in defined areas
- Reduce the risk of polluting the ground or water course
- Provide a cleaner, safer workplace for your staff.

## POLYETHYLENE ADVANTAGES

- Polyethylene has many advantages over steel, it normally represents a more cost effective solution, its lighter weight than a comparative steel version and it offers broadband chemical compatibility
- Rotationally moulded from Polyethylene our products are all designed with good housekeeping and compliance with regulations pertaining to the correct storage of liquids. The sumps conform to the 110% of the single largest item or 25% of the combined total of items, whichever is the greater rule and just as importantly they have all been designed with practicality and ease of use in mind.

## POLYETHYLENE COMPATIBILITY GUIDE

The list below is not exhaustive, it merely represents an extract from the data we hold, if you don't see a listing for your specific liquid please contact us to discuss, the Material Safety Data Sheet for the product is always the best source of this information.

- |                              |                               |                               |                             |
|------------------------------|-------------------------------|-------------------------------|-----------------------------|
| - Acetic acid 10%            | - Citric acid 25%             | - Hydrofluoric acid 40%       | - Phosphoric acid 25 to 50% |
| - Aluminium chloride Sat.sol | - Detergents, synthetic       | - Inks                        | - Photographic solutions    |
| - Aluminium sulphate Sat.sol | - Dextrose Sol                | - Iron (II) chloride Sat.sol  | - Sodium acetate Sat.sol    |
| - Ammonium acetate           | - Diethylene glycol           | - Iron (II) sulphate Sat.sol  | - Sodium bisulphate Sat.sol |
| - Ammonium chloride Sat.sol  | - Disodium phosphate          | - Iron (III) chloride Sat.sol | - Sulphuric acid 10%        |
| - Asorbic acid 10%           | - Emulsions, photographic     | - Iron (III) nitrate Sol      | - Sulphuric acid 50%        |
| - Barium carbonate Sat.sol   | - Ethyl alcohol 35%           | - Iron (III) sulphate Sat.sol | - Tannic acid Sol           |
| - Barium hydroxide Sat.sol   | - Ethyl alcohol 100%          | - Isopropanol                 | - Tartaric acid Sat.sol     |
| - Barium sulphate Sat.sol    | - Ethylene glycol 100%        | - Lactic acid 10%             | - Vanilla extract           |
| - Boric acid Sat.sol         | - Ferric Chloride Sat.sol     | - Lactic acid 28%             | - Vinegar                   |
| - Calcium carbonate Sat.sol  | - Ferric nitrate Sat.sol      | - Lactic acid up to 100%      | - Wetting agents            |
| - Calcium hypochlorite Sol   | - Ferric sulphate Sat.sol     | - Laytex                      | - Yeast Sol                 |
| - Calcium sulphate Sat.sol   | - Formaldehyde 40%            | - Mercury                     | - Zinc bromide Sat.sol      |
| - Castor oil Sol             | - Formic acid 40%             | - Milk                        | - Zinc chloride Sat.sol     |
| - Chromic acid Sat.sol       | - Formic acid 98 to 10%       | - Molasses work.con           |                             |
| - Citric acid Sat.sol        | - Fruit pulps Sol             | - Nickel chloride Sat.sol     |                             |
| - Citric acid 10%            | - Gelatine                    | - Nitric acid 25%             |                             |
|                              | - Glucose Sat.sol             | - n-Octane                    |                             |
|                              | - Glycerine 100%              | - Orthophosphoric acid 50%    |                             |
|                              | - Glycerol 100%               | - Perchloric acid 20%         |                             |
|                              | - Hydrochloric acid up to 36% | - Phosphoric acid up to 25%   |                             |
|                              | - Hydrochloric acid Conc      |                               |                             |

# POLYETHYLENE - DRUM & IBC STORAGE PRODUCTS

## SPILL PALLETS

### 1 TO 3 x 205LTR DRUMS

Your first line of defence to stop spill or leaking liquid contaminating the ground or water course.

For advice please contact us on **01506 430309/advice@empteezy.co.uk**

**EMPTEEZY**  
**5<sup>YR</sup> GUARANTEE**



### SPILL PALLETS

- All the containment capacities are fully compliant with UK regulations
- Rotationally moulded polyethylene construction means:
  1. Robust, hard wearing and long lasting
  2. Compatible with most liquids
  3. Great value for money
- Heavy duty version PP2HD capable of taking Uniform Distributed Loads of up to 1200kg.

### COMPLIANCE

- All products comply with the English and Scottish Oil Storage Regulations
- The contained area will hold 110% of the single largest item or 25% of the combined total of items, whichever is the greater.
- Colour option available on 2 drum version to allow you to match with existing pallets
- Spill pallets should only be moved when empty.



### SPILL PALLETS

All our prices include delivery to a mainland UK address

MODEL	SIZE L x W x H	SUMP CAPACITY	POLY MESH FLOOR	TARE WEIGHT	DELIVERED PRICE
PP1	900 x 700 x 525mm	225ltr	Standard	22kg	£191.00
PP2	1220 x 820 x 330mm	240ltr	Standard	34kg	£174.00
PP2Y	1220 x 820 x 330mm	240ltr	Standard	34kg	£174.00
PP2HD*	1290 x 875 x 345mm	240ltr	Standard	40kg	£240.00
PP3	1785 x 780 x 240mm	228ltr	Standard	35kg	£252.00

\*This pallet has been designed to be more robust than our standard 2 drum pallet, the heavy duty construction means that loads of up to 1200kg U.D.L. (Uniformed Distribution Load) can be stored.

# POLYETHYLENE - DRUM & IBC STORAGE PRODUCTS

## SPILL PALLETS

### 4 TO 8 x 205LTR DRUMS

Oils, chemicals and waste product all pose a hazard if they leak or spill, the simple solution is to contain the drums they are stored in.

To order please contact us on **01506 430309**/[www.empteezy.co.uk](http://www.empteezy.co.uk)

#### SPILL PALLETS

- Use anywhere you might otherwise have to stand drums directly on the ground
- Exceptional value for money compared to steel versions
- Excellent liquid compatibility.

#### COMPLIANCE

- No taps or drainage points to compromise the bunded area
- Fully meet the standards set out in The Oil Storage Regulations for the UK.

#### NOTE

- Colour option available on 4 drum version to allow you to match existing pallets
- Spill pallets should only be moved when empty
- 4 and 8 drum versions available in blue or yellow to match your existing spill pallets



**EMPTEEZY**  
5yr GUARANTEE



#### SPILL PALLETS

All our prices include delivery to a mainland UK address

MODEL	SIZE L x W x H	SUMP CAPACITY	POLY MESH FLOOR	TARE WEIGHT	DELIVERED PRICE
PP4	1310 x 1310 x 370mm	410ltr	Standard	44kg	£260.00
PP4L	1280 x 1280 x 275mm	230ltr	Standard	25kg	£221.00
PP4LY	1280 x 1280 x 275mm	230ltr	Standard	25kg	£221.00
PP8	2560 x 1350 x 510mm	1140ltr	Standard	136kg	£640.00
OPP8	2340 x 1360 x 510mm	1150ltr	No	85kg	£545.00
OPP8Y	2340 x 1360 x 510mm	1150ltr	No	85kg	£545.00

Letter Y at end of a code denotes YELLOW version

# POLYETHYLENE - DRUM & IBC STORAGE PRODUCTS

## SPIILGUARD PALLET CONVERTER

### 2 TO 4 x 205LTR DRUMS

The original and still the best on the market. If you want to keep drums on their shipping pallet and also want to ensure that if they leak they will be fully contained look no further.

To order please contact us on **01506 430309**/[www.empteezy.co.uk](http://www.empteezy.co.uk)

#### SPIILGUARD PALLET CONVERTER

- Quickly and simply contain your palletised drums
- Optional rain cover available for 4 drum version
- So robust that even running them over with the fork lift truck won't harm them.

#### COMPLIANCE

- Both versions have sumps that fully comply with current UK regulations.



#### SPIILGUARD PALLET CONVERTER

All our prices include delivery to a mainland UK address

MODEL	SIZE L x W x H	NO. OF DRUMS	SUMP CAPACITY	TARE WEIGHT	DELIVERED PRICE
GSPC2	1500 x 1100 x 440mm	2	270ltr	18kg	£216.00
GSPC4	1500 x 1300 x 440mm	4	330ltr	20kg	£241.00
GSPC2Y	1500 x 1100 x 440mm	2	270ltr	18kg	£216.00
GSPC4Y	1500 x 1300 x 440mm	4	330ltr	20kg	£241.00
GSPC1	Raincover for GSPC4 & GSPC4Y	-	-	3kg	£145.00

# POLYETHYLENE - DRUM & IBC STORAGE PRODUCTS

## IBC SPILL PALLETS

### 1 x 1000LTR IBC (INTERMEDIATE BULK CONTAINER)

Although regarded as one of the safest ways of transporting liquids, accidents still happen, by housing your IBC on a spill pallet you reduce the risk and ensure compliance.

For advice please contact us on **01506 430309/advice@empteezy.co.uk**



PIBC ALSO AVAILABLE  
IN YELLOW



### IBC SPILL PALLETS

- Two styles available either with or without a built-in dispensing area
- Suitable for most standard size 1000ltr IBC's
- Covered version for economical outdoor storage
- Retro fit dispensing tray available for models PIBC & CPIBC.

### COMPLIANCE

- All models are fully compliant with all current UK regulations
- Sumps hold 110% of the capacity of a 1000ltr IBC
- Spill pallets should only be moved when empty.



### IBC SPILL PALLETS

MODEL	SIZE L x W x H	SUMP CAPACITY	TARE WEIGHT	DELIVERED PRICE
PIBC	1760 x 1350 x 710mm	1100ltr	107kg	£557.00
CPIBC	1760 x 1350 x 2410mm	1100ltr	119kg	£969.00
PIBCD	1950 x 1400 x 725mm	1100ltr	86kg	£514.00
PIBCT*	550 x 545 x 855mm	86ltr	8.5kg	£113.00
PIBCY	1760 x 1350 x 710mm	1100ltr	107kg	£557.00
PIBCDY	1950 x 1400 x 725mm	1100ltr	86kg	£514.00
PIBCTY**	550 x 545 x 855mm	86ltr	8.5kg	£113.00

\*Tray & stand only for use with PIBC. \*\*Tray & stand only for use with PIBCY

Letter Y at end of a code denotes YELLOW version

# POLYETHYLENE - DRUM & IBC STORAGE PRODUCTS

## OPEN IBC SPILL PALLETS

### 1 TO 2 x 1000LTR IBC (INTERMEDIATE BULK CONTAINER)

Fully compliant spill pallets with easy access to the sump.

For advice please contact us on [01506 430309](tel:01506430309)/[advice@empteezy.co.uk](mailto:advice@empteezy.co.uk)

### OPEN IBC SPILL PALLETS

- This "open" design of spill pallet does away with the need for grid mesh, the IBC stands on support towers giving you easy access to the sump area
- Both models are available in blue or yellow
- The 2 x IBC versions are available with optional dispensing tray OPIBC2T or OPIBC2TY.



OPIBC



OPIBC2



OPIBC2T

#### IBC SPILL PALLETS

All our prices include delivery to a mainland UK address

MODEL	SIZE L x W x H	SUMP CAPACITY	TARE WEIGHT	DELIVERED PRICE
OPIBC	1590 x 1455 x 715mm	1125ltr	80kg	£490.00
OPIBCY	1590 x 1455 x 715mm	1125ltr	80kg	£490.00
OPIBC2	2340 x 1360 x 510mm	1150ltr	85kg	£545.00
OPIBC2T	530 x 520 x 450mm	86ltr	4kg	£75.00
OPIBC2Y	2340 x 1360 x 510mm	1150ltr	85kg	£545.00
OPIBC2TY	530 x 520 x 450mm	86ltr	4kg	£75.00

Letter Y at end of a code denotes YELLOW version

# POLYETHYLENE - DRUM & IBC STORAGE PRODUCTS

## IBC SPILL PALLETS

### 2 x 1000LTR IBC (INTERMEDIATE BULK CONTAINER)

Ensure your bulk liquids are stored so that they are contained in the event of a spill.

To order please contact us on **01506 430309**/[www.empteezy.co.uk](http://www.empteezy.co.uk)

#### IBC SPILL PALLETS

- Practical side by side storage for easy access to product
- Optional dispensing tray available
- Self assembly frame and cover version available for outdoor storage.

#### COMPLIANCE

- Compliant with both the English and Scottish Oil Storage Regulations.



PIBC2 SHOWN WITH 2 OPTIONAL DISPENSING TRAYS



#### IBC SPILL PALLETS

All our prices include delivery to a mainland UK address

MODEL	SIZE L x W x H	SUMP CAPACITY	TARE WEIGHT	DELIVERED PRICE
PIBC2	2560 x 1350 x 510mm	1140ltr	136kg	£636.00
PIBC2T	530 x 510 x 560mm	86ltr	4kg	£91.00
CPIBC2	2560 x 1350 x 2210mm	1140ltr	156kg	£1108.00



# POLYETHYLENE - DRUM & IBC STORAGE PRODUCTS

## COVERED SPILL PALLETTS & LOOSE COVERS

### 2 TO 8 x 205LTR DRUMS

If you need to store drums outdoors, these covered spill pallets are a cost effective way of keeping rainwater out of the sumps.

For advice please contact us on [01506 430309](tel:01506430309)/[advice@empteezy.co.uk](mailto:advice@empteezy.co.uk)



### COVERED SPILL PALLETTS

- Ensure the sump will still do its job and not overfill with rainwater
- Loose fit PVC covers available for 2 and 4 drum pallets
- Spill palletts with frame and cover for 3 to 8 x 205ltr drums.

### COMPLIANCE

- Limited space indoors and need to store your drums outdoors? Then these products are the simple, easy to use solution to staying compliant.
- Spill palletts should only be moved when empty.



### COVERED SPILL PALLETTS

MODEL	SIZE L x W x H	SUMP CAPACITY	POLY MESH FLOOR	TARE WEIGHT	DELIVERED PRICE
CPP3	1785 x 780 x 1945mm	228ltr	Standard	65kg	£565.00
CPP4	1415 x 1310 x 2070mm	410ltr	Standard	54kg	£552.00
CPP8	2560 x 1350 x 2210mm	1140ltr	Standard	156kg	£1108.00
PVC2-P	Cover only for PP2	n/a			£63.00
PVC4-P	Cover only for PP4L (image not shown)	n/a			£67.00

All our prices include delivery to a mainland UK address

# POLYETHYLENE - DRUM & IBC STORAGE PRODUCTS

## HARD COVERED SPILL PALLETS

### 5LTR CANS TO 205LTR DRUMS

Control access and help maintain the integrity of the sump with these hard covered lockable spill pallets.

To order please contact us on **01506 430309**/[www.empteezy.co.uk](http://www.empteezy.co.uk)

#### CP2 VERTICAL 205LTR DRUMS

- 2 x 205ltr vertical drums above a 260ltr sump.

#### CP2S VERTICAL 5LTR & 25LTR DRUMS

- Full grid mesh cover over 260ltr sump with further shelved area.

#### CP2H HORIZONTAL 205LTR DRUM

- 1 x 205ltr horizontal drum on a cradle above a 260ltr sump.

#### PP4HC & PP4HCY

- 4 x 205ltr drums vertical
- Low profile drum store with 410ltr sump available in blue or yellow.

#### FULLY COMPLIANT SUMPS

- Sump exceeds the 25% of the combined total of containers stored section of The Oil Storage Regulations.

**NEW  
PRODUCT**



#### HARD COVERED SPILL PALLETS

All our prices include delivery to a mainland UK address

MODEL	SIZE L x W x H	SUMP CAPACITY	POLY MESH FLOOR	TARE WEIGHT	DELIVERED PRICE
CP2	1630 x 940 x 1420mm	260ltr		95kg	£830.00
CP2S	1630 x 940 x 1420mm	260ltr		120kg	£929.00
CP2H	1630 x 940 x 1420mm	260ltr		110kg	£926.00
PP4HC	1470 x 1420 x 2070mm	410ltr	Standard	115kg	£985.00
PP4HCY	1470 x 1420 x 2070mm	410ltr	Standard	115kg	£985.00

# POLYETHYLENE - DRUM & IBC STORAGE PRODUCTS

## LOW PROFILE SPILL FLOORING & SPILL TRAYS

### 2 TO 4 x 205LTR DRUMS & 1 TO 4 x 25LTR DRUMS

Improve housekeeping and contain day to day leaks and drips.

For advice please contact us on [01506 430309](tel:01506430309)/[advice@empteezy.co.uk](mailto:advice@empteezy.co.uk)



### LOW PROFILE SPILL FLOORING

- Low height (150mm) makes it easy to load and unload
- 1000kg uniform distributed load per unit.

### COMPLIANCE

- Where any drum is used in conjunction with a drip tray as the secondary containment, it is sufficient if the tray has a capacity of 25% of the drum's storage capacity or if there is more than one drum used at the same time with the tray, the aggregate capacity of the drums.

### SPILL TRAYS

- Ideal for dosing points
- Store waste cooking oil prior to collection.

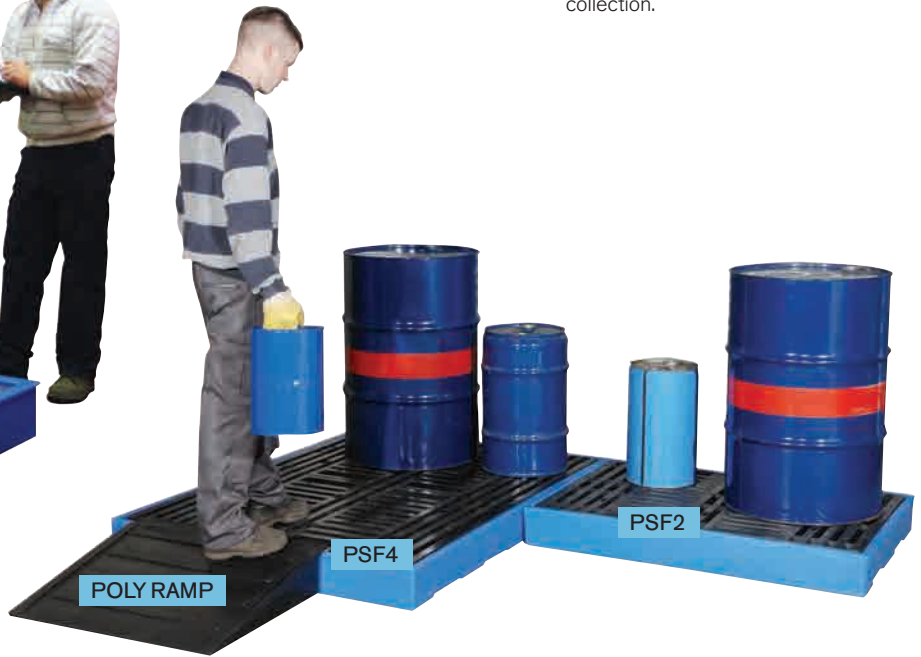

### LOW PROFILE SPILL FLOORING

All our prices include delivery to a mainland UK address

MODEL	SIZE L x W x H	CAPACITY	TARE WEIGHT	DELIVERED PRICE
PSF2	2-Drum – 1260 x 860 x 150mm	150ltr	20kg	£206.00
PSF4	4-Drum – 1660 x 1260 x 150mm	300ltr	40kg	£262.00
PSF4S	4 in a line – 2610 x 860 x 150mm	300ltr	51kg	£333.00
Polyramp	650 x 800 x 165mm	n/a	9kg	£121.00

### OPTIONS FOR SPILL FLOORING

All our prices include delivery to a mainland UK address

MODEL	DESCRIPTION	DELIVERED PRICE
PSFSTRIP	* PVC Joint cover per 1meter length	£25.00
PSFCONN	* Sump connector 1 inch BSP x 2	£26.00

### SPILL TRAYS

All our prices include delivery to a mainland UK address

MODEL	SIZE L x W x H	SUMP CAPACITY	TARE WEIGHT	DELIVERED PRICE
CAN25	1 x 25ltr – 550 x 550 x 110mm	27.5ltr	5kg	£62.00
CAN50	2 x 25ltr – 715 x 460 x 110mm	27.5ltr	5.5kg	£72.00
CAN100	4 x 25ltr – 920 x 720 x 175mm	100ltr	15kg	£127.00

# POLYETHYLENE - DRUM & IBC STORAGE PRODUCTS

## SPILL TRAYS

### 5LTR CANS TO 2 x 205LTR DRUMS

Improve housekeeping and ensure compliance with all the current UK regulations.

To order please contact us on **01506 430309**/[www.empteezy.co.uk](http://www.empteezy.co.uk)

#### SPILL TRAYS

- No more liquid on the floor to cause ground contamination
- No more liquid on the floor to cause a slip hazard to your staff
- 5 standard versions available from low profile to deep.

#### COMPLIANCE

- Where any drum is used for the storage of oil in conjunction with a drip tray as the secondary containment system, it is sufficient if the tray has a capacity of not less than 25% of (a) The drum's storage capacity; or (b) If there is more than one drum used at the same time with the tray, the aggregate storage capacity of the drums.



DT1

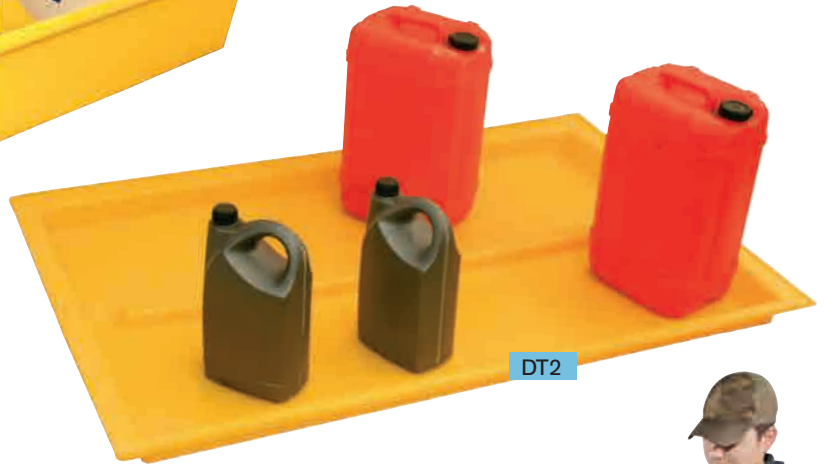

DT2



DT3



DT200



DT4

#### DRIP TRAYS

MODEL	SIZE L x W x H	TARE WEIGHT	CAPACITY	DELIVERED PRICE
DT1	630 x 590 x 170mm	4.5kg	45ltr	£47.00
DT2	1450 x 840 x 70mm	6kg	60ltr	£62.00
DT3	1200 x 550 x 50mm	3kg	25ltr	£30.00
DT4	1290 x 730 x 295mm	12kg	230ltr	£115.00

All our prices include delivery to a mainland UK address

#### CIRCULAR DRIP TRAY

MODEL	DIAMETER	HEIGHT	TARE WEIGHT	CAPACITY	DELIVERED PRICE
DT200	870mm	190mm	5kg	50ltr	£55.00

All our prices include delivery to a mainland UK address

# POLYETHYLENE - DRUM & IBC STORAGE PRODUCTS

## DRUM & IBC FUNNELS & DRUM COVERS

A cost effective and practical way of improving your facilities housekeeping.

For advice please contact us on [01506 430309](tel:01506430309)/[advice@empteezy.co.uk](mailto:advice@empteezy.co.uk)



### DRUM/IBC FUNNELS

- FL50 for "closed head" 205ltr drums, with hinged lid and cut-away for fill gauge
- FL100 for either "closed" or "open head" 205ltr drums, with hinged lid and a ribbed surface to allow items to drain. Debris strainer fitted as standard
- FL300 for "closed head" 205ltr drums, with location spout and debris strainer (no lid)
- FL200 for IBC's, 90mm drain with debris strainer and ribbed surface
- 08530 "drum full" indicator fits the 3/4" opening on a closed head drum.

### DRUM COVERS

- DVC loose fit cover for 205ltr drums
- DVC2 tight fit cover for 205ltr drums

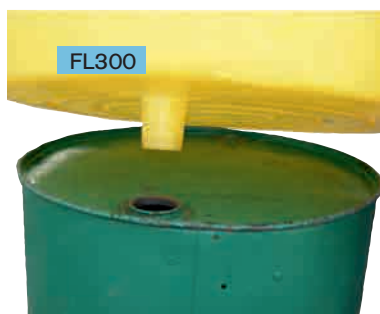

### DRUM & IBC FUNNELS

All our prices include delivery to a mainland UK address

MODEL	DIAMETER	HEIGHT	WEIGHT	DELIVERED PRICE
FL50	560mm	130mm	3kg	£47.00
FL100	610mm	230mm	4kg	£50.00
FL200	640mm	150mm	4kg	£62.00
FL300	870mm	240mm	5kg	£63.00
08530	n/a	n/a	n/a	£21.00

### DRUM COVERS

All our prices include delivery to a mainland UK address

MODEL	DIAMETER	HEIGHT	WEIGHT	DELIVERED PRICE
DCV	650mm	70mm	2kg	£36.00
DCV2	630mm	160mm	2kg	£39.00

# POLYETHYLENE - DRUM & IBC STORAGE PRODUCTS

## DRUM CRADLES TO AID DISPENSING FROM SMALL CONTAINERS & 205LTR DRUMS

The practical and safe way to dispense from your drums and containers.

For advice please contact us on [01506 430309](tel:01506430309)/[advice@empteezy.co.uk](mailto:advice@empteezy.co.uk)



**EMPTEEZY**  
5<sup>YR</sup> GUARANTEE

### SUMP CRADLE & STACKING UNIT

- PHD2 is a 400ltr sump with built-in cradles for 2 x 205ltr horizontal drums, by adding unit PSP1 you can stack a further 2 x 205ltr drums
- Maximum weight load 1200kg.

### MULTI USE DRUM CRADLE

- Use this cradle one way up for 205ltr drums, turn it over and use it for 25ltr and 50ltr drums.



### DRUM CRADLES

All our prices include delivery to a mainland UK address

MODEL	DESCRIPTION	SIZE L x W x H	CAPACITY	TARE WEIGHT	DELIVERED PRICE
PSP1	Stacker unit	1240 x 795 x 370mm	n/a	25kg	£139.00
PHD2	Sump base	1450 x 1310 x 485mm	400ltr	50kg	£423.00
PDC	Stacker for 1x 205ltr, or 1-2 x 25ltr drums	875 x 765 x 730mm	n/a	10kg	£91.00

# POLYETHYLENE - DRUM & IBC STORAGE PRODUCTS STORAGE & TRANSPORT BINS & CARTS

Tough and durable static and mobile storage containers for almost any application.

To order please contact us on **01506 430309**/[www.empteezy.co.uk](http://www.empteezy.co.uk)

## POLYETHYLENE CART

- PC1 transport your lose absorbents or rock salt right to the “scene of the crime” apart from the storage compartment there’s provision for tools and disposal bags too.



## 350LTR BINS

- PolyB gives you a liquid tight container with detachable lid and fork pockets to aid movement
- PolyB-C as previous model but fitted with two wheels and a castor, this version is not liquid tight.

## 1000LTR BINS

- Poly1000 is liquid tight and comes complete with a hinged and lockable lid and fork pockets to aid movement
- Poly1000-C as previous model but fitted with castors this version is not liquid tight.



## TOP LOADING BIN

- PolyC a static storage bin with hinged lid which has a variety of uses from “grit bin” for your rock salt to a static spill kit
- PolyC-C as previous model but fitted with castors.

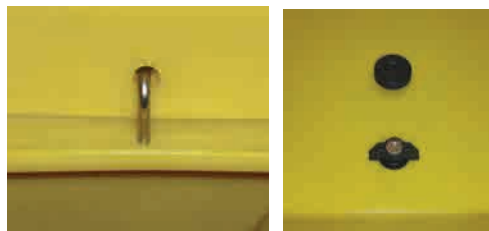

STAINLESS STEEL HINGES LOCKABLE LID

## STORAGE BINS & CARTS

All our prices include delivery to a mainland UK address

MODEL	SIZE L x W x H	CAPACITY	TARE WEIGHT	DELIVERED PRICE
PolyB	1265 x 855 x 910mm	350ltr	26kg	£156.00
PolyB-C	PolyB fitted with castors (not liquid tight)	350ltr	31kg	£240.00
Poly1000	1460 x 1010 x 975mm	1000ltr	35kg	£355.00
Poly1000-C	Poly1000 fitted with castors (not liquid tight)	1000ltr	40kg	£462.00
PC1	1360 x 710 x 965mm	60ltr	40kg	£472.00
PolyC	875 x 875 x 810mm	220ltr	20kg	£225.00
PolyC-C	875 x 875 x 830mm fitted with castors (not liquid tight)	220ltr	23kg	£275.00

# POLYETHYLENE - DRUM & IBC STORAGE PRODUCTS

## TROLLEYS

### WITH CONTAINMENT AREAS

Move drums and containers around your facility in the safe knowledge that any leak or spill will be fully contained.

To order please contact us on **01506 430309**/[www.empteezy.co.uk](http://www.empteezy.co.uk)

#### 205LTR DISPENSING TROLLEY

- PT10 is a "one person" operated trolley that allows you to simply tip a 205ltr drum from the vertical to the horizontal position and move it with ease
- 260ltr sump and dispensing area means that even if the entire contents leaked out it would be fully contained.



**EMPTEEZY**  
5<sup>YR</sup> GUARANTEE

#### SMALL TROLLEY

- PT5 with a 47ltr capacity this trolley is useful for moving 25ltr drums, vehicle batteries and other small loads around your facility.



#### SINGLE DRUM TROLLEY

- PT1 a mobile drip tray that aids housekeeping when transporting and dispensing from vertical drums.

#### NONE OF THESE ITEMS ARE SUITABLE FOR DISPENSING FLAMMABLE LIQUID FROM



ATTACH



TILT



PUSH

#### TROLLEYS

MODEL	SIZE L x W x H	CAPACITY	TARE WEIGHT	DELIVERED PRICE
PT10	1600 x 740 x 640mm	230ltr	44kg	£386.00
PT5	900 x 700 x 300mm (980mm to top of handle)	47ltr	18kg	£222.00
PT1	725 x 725 x 255mm (990mm to top of handle)	30ltr	15.5kg	£148.00

All our prices include delivery to a mainland UK address



# POLYETHYLENE - DRUM & IBC STORAGE PRODUCTS

## CUPBOARDS WITH BUILT-IN SUMPS

Designed primarily to hold drums and small containers these cupboards can of course be used for many other things.

For advice please contact us on [01506 430309](tel:01506430309)/[advice@empteezy.co.uk](mailto:advice@empteezy.co.uk)

**EMPTEEZY**  
**5yr GUARANTEE**



PAS2



PAS1

### CUPBOARDS

- PAS1 & PAS2 are supplied with shelves and lockable doors, ideal for storing small containers, cleaning items, absorbents and personal protective equipment etc.
- PAS1 Colours: Solid yellow, red, green, blue or white body with door yellow, red, green or blue
- PAS2 Colours: Solid yellow, red, green or white body with door yellow, red, green or blue
- CP1 big enough to take a 205ltr drum this unit has a 250ltr sump and a lockable door
- CP1 colours: Solid yellow, red, green or blue
- CP1S has the same 250ltr sump and lockable door but is fitted with a shelf making it more suited to 25ltr drums
- CP1S Colours: Solid yellow, red, green or blue
- CP3 gives your staff controlled access to product on the shop floor (save time going backwards and forwards to the stores). The 100ltr sump makes it ideal for 4 x 25ltr drums
- CP3 colours: Solid yellow, red, green, blue or white body with door yellow, red, green or blue



CP1S



CP1



CP3

### CUPBOARDS

All our prices include delivery to a mainland UK address

MODEL	SIZE L x W x H	SUMP CAPACITY	SHELVES	TARE WEIGHT	DELIVERED PRICE
PAS1	545 x 440 x 990mm	30ltr	2	15kg	£250.00
PAS2	650 x 570 x 1650mm	70ltr	3	40kg	£402.00
CP1	920 x 720 x 1835mm	250ltr	n/a	56kg	£651.00
CP1S	920 x 720 x 1835mm	250ltr	1	60kg	£696.00
CP3	920 x 720 x 1520mm	100ltr	n/a	52kg	£585.00

# POLYETHYLENE - DRUM & IBC STORAGE PRODUCTS

## COLUMN GUARD

### BUILDING PROTECTION DEVISE

A self-install column protection system available in 5 standard sizes.

To order please contact us on **01506 430309**/[www.empteezy.co.uk](http://www.empteezy.co.uk)

#### COLUMN GUARD

- Protect the fabric of your building and reduce damage to your fork lift trucks
- Just clamp around the column and bolt together, it's that simple
- Completely maintenance free once fitted
- **STANDARD COLOUR YELLOW BUT AVAILABLE IN RED TO SPECIAL ORDER.**

**NOT SUITABLE FOR USE WITH CAST IRON COLUMNS**

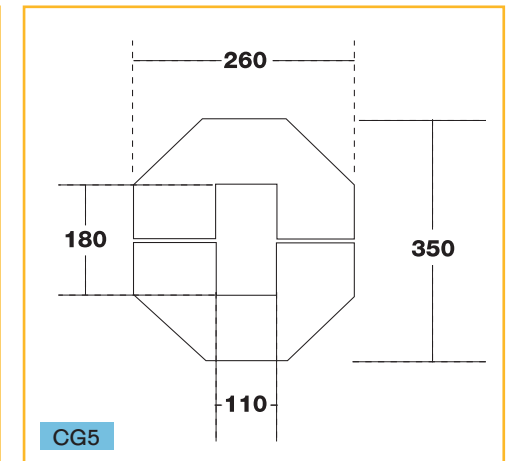
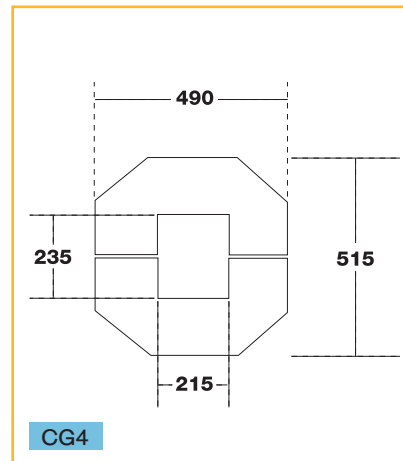
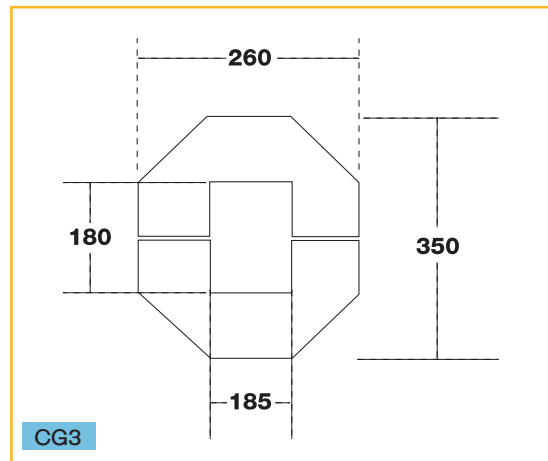
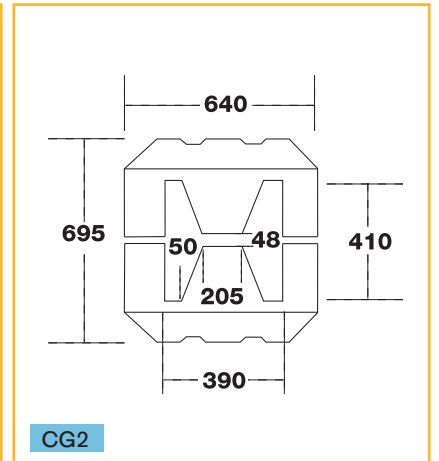
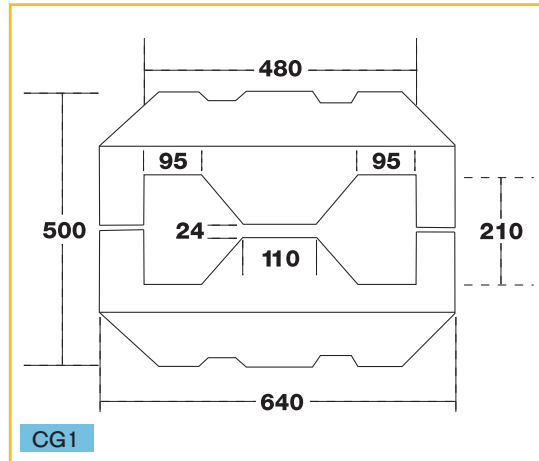

#### COLUMN GUARD

MODEL	SIZE L x W x H	COLOUR	TARE WEIGHT	DELIVERED PRICE
CG1	640 x 500 x 985mm	Yellow	34kg	£217.00
CG2	695 x 640 x 985mm	Yellow	39kg	£214.00
CG3	350 x 260 x 950mm	Yellow	12kg	£211.00
CG4	515 x 490 x 950mm	Yellow	18kg	£208.00
CG5	350 x 260 x 950mm	Yellow	12kg	£205.00

All our prices include delivery to a mainland UK address



# DRUM & IBC STORAGE/ STEEL PRODUCTS



# BEST BUYS

Looking for versatility? **DS4S** lets you store up to 4 x 205ltr drums (vertically) with space above for 25ltr cans. At only £1847.00 including delivery to a mainland UK address this secure and robust store is practical and compliant with UK regulations – SEE PAGE 77



Secure outdoor storage for 16 x 205ltr drums or 4 x 1000ltr IBC's **DPU16-4** £4647.00 delivered to a mainland UK address and backed by a 20 year structural guarantee – SEE PAGE 79



Keep your gas cylinders safe and secure in our **GB30** (store up to 27 x 285mmØ cylinders) which can be finished in a colour to reflect the gases stored. £3553.00 including delivery to a mainland UK address – SEE PAGE 89



**CS2 Chemstor®** a fully bunded walk-in store complete with robust racking to accommodate up to 72 x 25ltr cans. £4319.00 delivered to a mainland UK address and backed by a 20 year structural guarantee – SEE PAGE 91



# DRUM & IBC STORAGE/STEEL PRODUCTS INTRODUCTION

For advice on liquid storage please contact us on **01506 430309/advice@empteezy.co.uk**

- As you are all too aware The Oil Storage Regulations (please see pages 50 and 51 for information on storing oils) are amongst some of the most highly publicised regulations currently in force and it's all too easy to forget that all liquids pose a potential threat to health and safety and the environment if not properly stored and handled. There are a lot of other regulations that you need to be aware of, and in compliance with but one that we feel you should be aware of is the Water Resources Act 1991.

## CONTACT US

- Contact us today to arrange a site survey and reduce the risk of you and your company being liable to prosecution  
Tel 01506 430309 or email [advice@empteezy.co.uk](mailto:advice@empteezy.co.uk)

## BACKGROUND

- The Act sets out the responsibilities of the Environment Agency in relation to water pollution, resource management, flood defence, fisheries, and in some areas, navigation. The Act regulates discharges to controlled waters, namely rivers, estuaries, coastal waters, lakes and ground waters. This is distinct from the drainage of water or trade effluent from trade premises into a sewer. Discharge to controlled waters is only permitted with the consent of the Environment Agency. An aim of the Act is to ensure that the polluter pays the cost of the consequences of their discharges.

## KEY ISSUES FOR INDUSTRY

- Section 85 of the Act states that 'no person shall cause or knowingly permit any poisonous, noxious or toxic material or solid waste to enter a controlled water'. 'Causing' means not only deliberately releasing any polluting matter but also causing the pollution accidentally by being the operator of a plant or process.



# DRUM & IBC STORAGE/STEEL PRODUCTS

To order please contact us on **01506 430309**/[www.empteezy.co.uk](http://www.empteezy.co.uk)

## **THE ANTI POLLUTION WORKS REGULATIONS 1999**

- The Anti-Pollution Works Regulations were enacted into Section 161A of the Water Resources Act, to enable the Environment Agency to serve works notices on polluters or prospective polluters. The purpose of the regulations is to provide the Agency with additional powers to prevent water pollution. Notices may be served on anyone who has 'caused or knowingly permitted' or potentially may 'allow' polluting matter to enter controlled waters
- The Agency is entitled to recover the costs of any investigations needed, to determine the source of the pollution from the person(s) on whom the notice was served. The Agency conducts a risk assessment to determine whether a Works Notice should be served. The storage and handling of chemicals should be undertaken in a manner in which the risk of spillages and leakages are reduced as far as practicable.

## **INFORMATION GUIDE**

- Using the following information as a guide will help you select the correct storage units to suit your specific requirements and when used in conjunction with other measures including good housekeeping, spill kits and training will substantially reduce the risk of a pollution incident
- Product specific information can be gleaned from the Material Safety Data Sheet (MSDS) to help with issues relating to compatibility, fire, explosion or vapour release risks
- When deciding the type of unit and its possible location we recommend that you talk to your insurance company and the local authority fire brigade prior to purchase, as they very often have a view point in relation to associated risks to existing buildings etc.
- As an alternative to carrying out this assessment yourself, why not invite an "outside pair of eyes" in to carry it for you. We have a team of experienced staff available to carry out a full, in depth site assessment, it carries no costs, no commitment or onus upon you to buy anything, and with over 22 years of experience designing and manufacturing drum and IBC storage units for Industrial, Commercial, Institutional and Military clients what have you got to lose?

## **10 QUESTIONS TO ASK YOURSELF BEFORE BUYING A DRUM OR IBC STORAGE UNIT**

- 1 **What liquids are you looking to store?**
- 2 **How many litres of each liquid do you want to store?**
- 3 **What size and number of drums and IBC's will require storage?**
- 4 **Are the products to be stored indoors or outdoors?**
- 5 **If indoors, are there any access, issues or internal drainage systems?**
- 6 **If outdoors are there surface water drains or a water course in the vicinity?**
- 7 **How will the containers be delivered to site?**
- 8 **How will they be placed in and removed from the storage unit?**
- 9 **Is there a requirement to store any of the liquids separately?**
- 10 **Is there a fire, explosion or vapour release risk associated with any of the liquids?**

# DRUM & IBC STORAGE/STEEL PRODUCTS

## SPILL PALLETS

### 2 TO 8 x 205LTR VERTICAL DRUMS

Don't let leaking drums create pollution problems, store them safely on a fully contained spill pallet.

For advice on liquid storage please contact us on [01506 430309](tel:01506430309)/[advice@empteezy.co.uk](mailto:advice@empteezy.co.uk)



PVC4



SP2

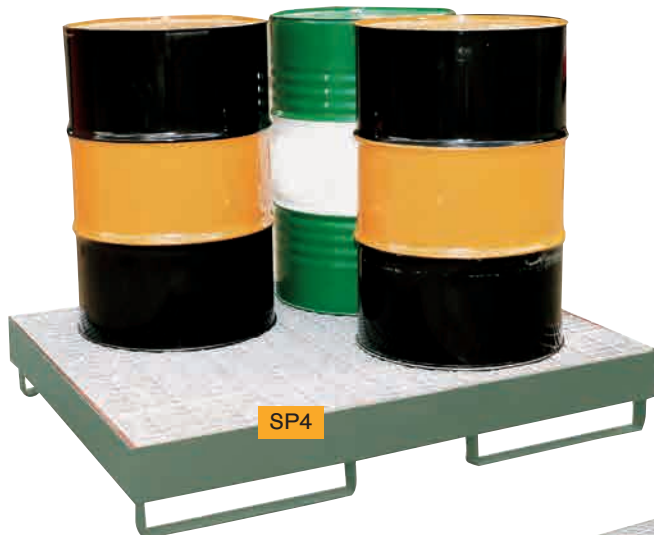

SP4



SP8

## SPILL PALLETS

- When liquids aren't compatible with polyethylene or you need to place your drums near a heat source use steel
- If you are constantly moving drums on and off your spill pallets use the extra strength of a steel pallet and it will last longer
- All models have removable galvanised mesh decks for easy cleaning of the sump
- Fork hoops make for easy movement and keep the underside of the sump off the ground.

## ACCESSORIES

- Slip-over covers help keep the rain out so the sump capacity is not compromised.
- All our steel spill pallets have sump capacities that are fully compliant with current UK regulations.

STANDARD COLOUR: GREEN RAL 6029

### SPILL PALLETS

All our prices include delivery to a mainland UK address

MODEL	SIZE L x W x H	NO. DRUMS	SUMP	TARE WEIGHT	DELIVERED PRICE
SP1	800 x 800 x 485mm	1	225ltr	42kg	£379.00
SP2	1500 x 800 x 295mm	2	230ltr	62kg	£409.00
SP4	1500 x 1220 x 240mm	4	250ltr	108kg	£486.00
SP8	2500 x 1250 x 320mm	8	560ltr	190kg	£854.00

### POLYETHYLENE COVERS

All our prices include delivery to a mainland UK address

MODEL	SIZE L x W x H	USE WITH	DELIVERED PRICE
PVC2	1505 x 805 x 950mm	SP2	£63.00
PVC4	1505 x 1225 x 1050mm	SP4	£67.00
PVC8	2505 x 1225 x 1050mm	SP8	£89.00

# DRUM & IBC STORAGE/STEEL PRODUCTS

## SPILL PALLETS

### 1 TO 4 x 205LTR VERTICAL & HORIZONTAL DRUMS

These enclosed units protect the drums and allow you to move the pallet with the drum(s) in situ.

To order please contact us on **01506 430309**/[www.empteezy.co.uk](http://www.empteezy.co.uk)

#### SPILL PALLETS

- Use to protect drums in areas where they are at risk of being knocked into
- Vertical models come complete with a safety chain to aid retention of the drum during transit
- Horizontal models can be fitted with a sliding carriage system to aid loading and unloading (can't be stacked if this option is fitted)
- All models can be stacked up to 3 high.



VD1



VD4



VD2



SLC

SLIDING CARRIAGE



HD2



HD4

STANDARD COLOUR: GREEN RAL 6029

SHOWN IN NON STANDARD RED

#### SPILL PALLETS

All our prices include delivery to a mainland UK address

MODEL	SIZE L x W x H	NO. DRUMS	SUMP	TARE WEIGHT	DELIVERED PRICE
HD1*	1300 x 880 x 1220mm	1	225ltr	64kg	£541.00
HD2*	1580 x 1320 x 1220mm	2	270ltr	141kg	£725.00
HD4*	1580 x 1320 x 2020mm	4	370ltr	198kg	£888.00
VD1	800 x 800 x 1375mm	1	225ltr	76kg	£547.00
VD2	1580 x 830 x 1300mm	2	260ltr	90kg	£721.00
VD4	1580 x 1320 x 1300mm	4	370ltr	152kg	£919.00

\*Option: Sliding carriage. (SLC) £652/Pair. Units cannot be stacked if fitted with this option.



# DRUM & IBC STORAGE/STEEL PRODUCTS SPILL FLOORING & TROLLEYS CREATE A SAFER WORKING ENVIRONMENT

Use spill flooring to bund a working area or move drums on a fully bunded trolley.

For advice on liquid storage please contact us on [01506 430309](tel:01506430309)/[advice@empteezy.co.uk](mailto:advice@empteezy.co.uk)



## SPILL FLOORING

- Join sections together to create a fully contained workstation
- Only 110mm high means easy access via the optional ramp or a suitable trolley.

## STEEL DRUM TROLLEYS

- ST1 store & transport a single vertical 205ltr drum on a 240ltr sump, comes complete with retaining strap and removable galvanised grid deck
- ST2 store & transport 2 x 205ltr vertical drums on a 240ltr sump, complete with removable galvanised grid deck
- ST2F store & transport a single horizontal 205ltr drum on a 240ltr sump, complete with dispensing cradle (fitted with rollers to allow the drum to be rotated)
- All models are fitted with two fixed and two swivel 150mm brake castors.



STANDARD COLOUR: GREEN RAL 6029

### SPILL FLOORING

All our prices include delivery to a mainland UK address

MODEL	SIZE L x W x H	SUMP	TARE WEIGHT	DELIVERED PRICE
SF10	1050 x 1050 x 110mm	110ltr	80kg	£448.00
SF20	2300 x 1050 x 110mm	230ltr	125kg	£752.00
SF30	2800 x 1300 x 110mm	360ltr	170kg	£787.00
SFRAMP	1000 x 500 x 110mm	n/a	16kg	£162.00
SFSTRIP	*Joint strip per 1metre length	n/a		£24.00

### SPILL TROLLEYS

All our prices include delivery to a mainland UK address

MODEL	SIZE L x W x H	NO. DRUMS	SUMP	TARE WEIGHT	DELIVERED PRICE
ST1	800 x 800 x 1050mm	1	240ltr	64kg	£615.00
ST2	1400 x 750 x 1050mm	2	250ltr	60kg	£648.00
ST2F	1400 x 750 x 1050mm	1	250ltr	80kg	£778.00

# DRUM & IBC STORAGE/STEEL PRODUCTS

## SPILL PALLETS FOR 1000LTR IBC (INTERMEDIATE BULK CONTAINER)

Steel manufactured units are often the solution for the safe storage of IBC's being used in a "hostile / tough" environment, for example a foundry where heat is an issue.

To order please contact us on **01506 430309**/[www.empteezy.co.uk](http://www.empteezy.co.uk)

### IBC SPILL PALLETS

- IBC standard pallet
- IBCD standard pallet fitted with an angled dispensing frame that aids complete drainage of the IBC
- IBC2 if space is at a premium this unique solution could be what you are looking for. If the upper IBC leaks the liquid is channelled via the hollow support frame to the main sump
- IBC2S store 2 x 1000ltr IBC's side by side.
- All models come complete with galvanised removable grid decks to aid cleaning of the sump
- All sumps comply with current UK regulations
- All models are fitted with fork hoops to aid movement (when empty) and keep the base of the sump off the floor.



STANDARD COLOUR: GREEN RAL 6029

### IBC SPILL PALLETS

All our prices include delivery to a mainland UK address

MODEL	SIZE L x W x H	NO. IBC	SUMP	TARE WEIGHT	DELIVERED PRICE
IBC	1400 x 1640 x 600mm	1	1125ltr	215kg	£1049.00
IBCD	1400 x 1640 x 1000mm	1	1125ltr	160kg	£1187.00
IBC2	1400 x 1640 x 2480mm	2	1125ltr	380kg	£1490.00
IBC2S	2800 x 1640 x 410mm	2	1340ltr	360kg	£1465.00
PVCIBC	1405 x 1640 x 1250mm	n/a	cover for use with IBC		£87.00

# DRUM & IBC STORAGE/STEEL PRODUCTS

## OPEN DRUM STORES 8 TO 32 x 205LTR DRUMS

Just because drums are kept indoors doesn't mean they can't cause pollution, if un-contained any spilt liquid could access internal drains or run under doors to outside drains. The spill will also pose a hazard to staff.

For advice on liquid storage please contact us on [01506 430309](tel:01506430309)/[advice@empteezy.co.uk](mailto:advice@empteezy.co.uk)

### DRUM STORES

- All sumps comply with the 25% of the combined total of containers stored rule
- All sumps are FULLY seam welded
- All sumps are fitted with base plinths to eliminate sump contact with the ground
- All sumps are fitted with removable galvanised grid mesh decks for easy access
- Units are enclosed on 3 sides apart from IS12H which has enclosed sides and an open back with "stop rails".



STANDARD COLOUR: GREEN RAL 6029

### OPEN DRUM STORES

All our prices include delivery to a mainland UK address

MODEL	SIZE L x W x H	NO. DRUMS	SUMP	TARE WEIGHT	DELIVERED PRICE
IS8B	3000 x 1500 x 1625mm	8	1125ltr	350kg	£2162.00
IS12H	3000 x 1500 x 3200mm	12	1125ltr	700kg	£3196.00
IS16B	3000 x 1500 x 2355mm	16	1125ltr	500kg	£3309.00
IS32B	5920 x 1500 x 2355mm	32	2100ltr	700kg	£5687.00

# DRUM & IBC STORAGE/STEEL PRODUCTS

## FULLY ENCLOSED SECURE DRUM STORES

### 1 TO 8 x 205LTR DRUMS

Use indoors or outdoors to control who has authorized access and reduce the risk of vandalism which is unfortunately a significant cause of pollution incidents.

To order please contact us on **01506 430309**/[www.empteezy.co.uk](http://www.empteezy.co.uk)

#### DRUM STORES

- HD2D & VD4D fitted with hinged lids, gas struts and stay bars for easy access (these models are not recommended for outdoor use)
- HD2D & HD4D can be fitted with an optional sliding carriage to aid loading and unloading
- All models are of an all welded construction and have fully seam welded sumps
- All sumps comply with the 25% of the combined total of containers stored rule.



STANDARD COLOUR: GREEN RAL 6029

#### FULLY ENCLOSED SECURE DRUM STORES

All our prices include delivery to a mainland UK address

MODEL	SIZE L x W x H	NO. DRUMS	SUMP	TARE WEIGHT	DELIVERED PRICE
*HD2D	1500 x 1250 x 1470mm	2	370ltr	284kg	£1557.00
*HD4D	1500 x 1500 x 2090mm	4	420ltr	382kg	£1738.00
VD1D	800 x 800 x 1435mm	1	225ltr	100kg	£1123.00
VD2D	1500 x 750 x 1360mm	2	260ltr	137kg	£1320.00
VD4D	1500 x 1250 x 1470mm	4	370ltr	279kg	£1671.00
DS4S	1500 x 1500 x 2090mm	4 x 205 + 25ltr	420ltr	464kg	£1847.00
DS2P	1460 x 1460 x 2680mm	8	450ltr	360kg	£2486.00

\*Option: Sliding carriage. (SLC) £652/Pair.

# DRUM & IBC STORAGE/STEEL PRODUCTS

## FULLY ENCLOSED SECURE DRUM STORES

### 8 x 205LTR DRUMS

Three models that have been designed to give you practical options on the way you store and use your drum stores.

For advice on liquid storage please contact us on [01506 430309](tel:01506430309)/[advice@empteezy.co.uk](mailto:advice@empteezy.co.uk)



### DRUM STORES

- DS8S if all you want to do is securely store your drums prior to use, then this is the model for you
- DS8SE if however you need the ability to connect funnels or pumps to the drums or you have an IBC that needs storing too then the extra height in this model makes it ideal
- DS12S store 4 x 205ltr drums stored horizontally on one side of this unit and 4 x 205ltr drums vertically on the other side, with a shelf above the vertical drums for small containers
- DS16HS stores 16 x 205ltr vertical drums on 1 level
- DS32R hold 32 x 20ltr vertical drums on two levels and has electrically operated roller shutter doors.
- All units have: removable galvanised grid decks, lockable sliding doors, crane lifting points, sloping roofs with a rain channel and base plinths to eliminate ground contact with the sump.
- All sumps are fully compliant with current UK regulations.

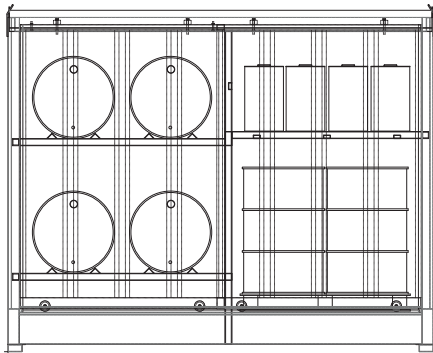

STORAGE LAYOUT IN A DS12S

**20<sup>YR</sup> STRUCTURE GUARANTEE**



STANDARD COLOUR: GREEN RAL 6029

### FULLY ENCLOSED SECURE DRUM STORES

All our prices include delivery to a mainland UK address

MODEL	SIZE L x W x H	NO. DRUMS	SUMP	TARE WEIGHT	DELIVERED PRICE
DS8S	3000 x 1500 x 1675mm	8	1125ltr	702kg	£2648.00
DS8SE	3000 x 1500 x 2405mm	8	1125ltr	938kg	£3663.00
DS12S	3000 x 1500 x 2405mm	4Hor - 4Vert	1125ltr	1008kg	£3801.00
DS16HS	5920 x 1500 x 1675mm	16	2200ltr	1200kg	£5520.00
DS32R	5920 x 1500 x 3505mm	32	2200ltr	1800kg	POA

# DRUM & IBC STORAGE/STEEL PRODUCTS

## FULLY ENCLOSED DRUM OR IBC STORES

### 205LTR DRUMS OR 1000LTR IBC

With the use of IBC's becoming more prevalent we have designed our stores to accommodate drums and/or IBC.

To order please contact us on **01506 430309**/[www.empteezy.co.uk](http://www.empteezy.co.uk)

#### IBC STORES

- IB1DS twin hinged lockable doors and 110% capacity sump
- IB2DS twin sliding lockable doors and additional height space for funnels or pumps
- DPU16-4 twin sliding lockable doors and a "Support Beam" shelf for top 2 IBC's.
- All units have: removable galvanised sump grid mesh, crane lifting points, sloping roofs with a rain channel and base plinths to eliminate ground contact with the sump (Grid mesh available for shelving at additional cost)
- All sumps are fully compliant with current UK regulations.



**20<sup>YR</sup> STRUCTURE GUARANTEE**



STANDARD COLOUR: GREEN RAL 6029

#### FULLY ENCLOSED SECURE DRUM OR IBC STORE

All our prices include delivery to a mainland UK address

MODEL	NO. IBC	NO. DRUMS	SIZE L x W x H	SUMP CAPACITY	TARE WEIGHT	DELIVERED PRICE
IB1DS	1	4	1500 x 1400 x 2350mm	1470ltr	560kg	£2455.00
IB2DS	2	8	3000 x 1500 x 2450mm	1125ltr	1050kg	£3639.00
DPU16-4	4	16	3000 x 1500 x 3275mm	1125ltr	1160kg	£4220.00

# DRUM & IBC STORAGE/STEEL PRODUCTS

## FULLY ENCLOSED DRUM OR IBC STORES

### 205LTR DRUMS OR 1000LTR IBC

Whether yard space is an issue or not we have the answer with the option of access from both sides of the unit or push-back loading which allows access from one side if the unit needs placing against a wall.

For advice on liquid storage please contact us on **01506 430309/advice@empteezy.co.uk**



## IBC STORES

- DPU32-8 store 8 x 1000ltr IBC's (4 per level) in a single pallet depth unit
- DPU48-12 store 12 x 1000ltr IBC's (6 per level) in a single pallet depth unit
- DPU64-16 store 16 x 1000ltr IBC's (8 per level) in a double pallet depth unit with doors on both sides
- DPU96-24 store 24 x 1000ltr IBC's (12 per level) in a double pallet depth unit with doors on both sides
- DPU64-16PB store 16 x 1000ltr IBC's (8 per level) in a double pallet depth unit with doors on 1 side only, fitted with Push Back Loading
- DPU96-24PB store 24 x 1000ltr IBC's (12 per level) in a double pallet depth unit with doors on 1 side only, fitted with Push Back Loading
- Push Back Loading is a simple way of gaining access to pallets without the need for extended forks or up rated fork lift trucks. A "sliding rail" device allows the pallet to be pushed to the back of the unit. The front pallet controls the movement of the back one.
- All units have: removable galvanised sump grid mesh, "Support Beam" shelves, lockable sliding doors, crane lifting points, sloping roofs with a rain channel and base plinths to eliminate ground contact with the sump (Grid mesh available for shelving at additional cost).
- All sumps are fully compliant with current UK regulations.



**20<sup>yr</sup> STRUCTURE GUARANTEE**



PUSH BACK LOADING

STANDARD COLOUR: GREEN RAL 6029 SHOWN  
WITH OPTIONAL TOP SHELF GRID MESH

### FULLY ENCLOSED DRUM OR IBC STORE

All our prices include delivery to a mainland UK address

MODEL	NO. IBC	NO. DRUMS	SIZE L x W x H	SUMP CAPACITY	TARE WEIGHT	DELIVERED PRICE
DPU32-8	8	32	5920 x 1500 x 3275mm	2200ltr	1970kg	£5890.00
DPU48-12	12	48	8840 x 1500 x 3275mm	3300ltr	2800kg	£8240.00
DPU64-16	16	64	5920 x 2800 x 3325mm	4100ltr	3100kg	£9140.00
DPU64-16PB	16	64	5920 x 2800 x 3660mm	4100ltr	3400kg	£10216.00
DPU96-24	24	96	8840 x 2800 x 3325mm	6100ltr	4100kg	£14490.00
DPU96-24PB	24	96	8840 x 2800 x 3660mm	6100ltr	4400kg	£13840.00

# DRUM & IBC STORAGE/STEEL PRODUCTS

## SECURE COMBINATION STORES

### FULLY ENCLOSED

If you have a need to store liquids in pallet quantities and also require a fully contained, secure work area then these units are the answer to that need.

To order please contact us on **01506 430309**/[www.empteezy.co.uk](http://www.empteezy.co.uk)

### COMBI-STORE

- CBS1 a 6m long unit with a 16 x 205ltr vertical drum store built in to one end with the remaining space (approx 4.5m) a fully contained work area with 3 sets of shelves
- CBS2 as above but with a 16 x 205ltr drum store at each end leaving a 3m (approx) work area in between
- The end storage units are designed to accommodate IBC's too and will hold 4 per unit
- These units can be customized to suit your specific needs for example; the sump can be compartmentalized for the safe storage of incompatible liquids.

**20<sup>YR</sup> STRUCTURE GUARANTEE**

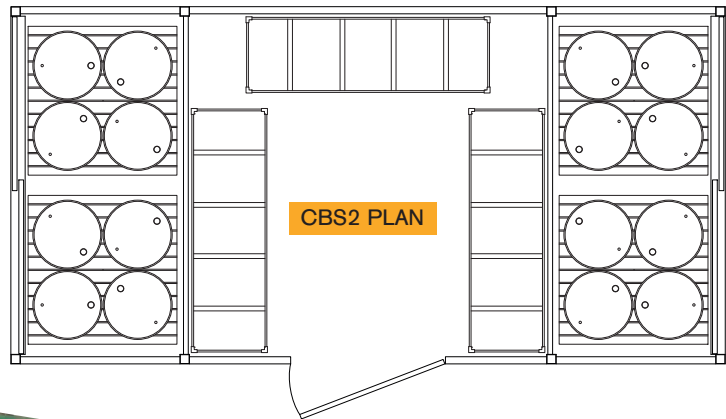
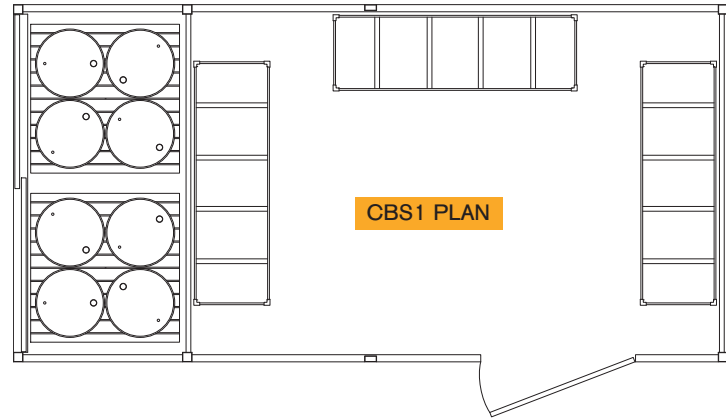

STANDARD COLOUR: GREEN RAL 6029

### COMBI-STORE SECURE COMBINATION STORES

All our prices include delivery to a mainland UK address

MODEL	OVERALL L x W x H	SUMP CAPACITY	TARE WEIGHT	DELIVERED PRICE
CBS1	6000 x 3000 x 3325mm	4500ltr	3000kg	£9948.00
CBS2	6000 x 3000 x 3325mm	4500ltr	3000kg	£11107.00



# DRUM & IBC STORAGE/STEEL PRODUCTS

## FLAT PACK SELF-BUILD STORES

### WITH SUMP AREA TO CONTAIN LEAKS

With more and more legislation applying to the correct storage of liquids, the cost to some businesses of installing the correct equipment can be prohibitive. This range of self-build stores offers an economical solution.

For advice on liquid storage please contact us on **01506 430309/advice@empteezy.co.uk**



SMC31 OPENED



### UNITS FOR SELF-ASSEMBLY

### SECURE ECONOMY BUNDED STORES

- Fully galvanised side and roof panels
- Powder coat paint finish double access doors
- Two 64mm Euro deadlocks with replaceable cylinders and a central roller catch
- Fully banded floor with suspended grid mesh deck
- Roof has two integral gutters for effective rainwater dispersal to all four corners of the unit
- A framework is bolted to the chassis and the panels and roof are in turn bolted to the frame
- 4 x12mmØ rods are used to connect the roof to the chassis and are used as lifting points for the unit.

### ACCESSORIES

- 1m 3 shelves kit £235
- 1.9m 3 shelves kit £385

### NOTE

- Full "how to build" instructions are supplied with each unit
- Pre-built option available, please contact us to discuss.



SUMP BASE



DOUBLE LOCKING AS STANDARD

### FLAT PACK SELF-BUILD STORES

All our prices include delivery to a mainland UK address

MODEL	SIZE L x W x H	SUMP	TARE WEIGHT	DELIVERED PRICE
SMC21	2305 x 2160 x 2247mm	830ltr	520kg	£2039.00
SMC31	3080x 2160 x 2247mm	1064ltr	633kg	£2352.00
SMC41	4080 x 2160 x 2247mm	1420ltr	781kg	£2980.00

# DRUM & IBC STORAGE/STEEL PRODUCTS

## SECURE DRY GOODS STORE

### FULLY ENCLOSED

If you have limited indoor storage space this unit can provide the solution, its solid frame is clad with Plastisol and access is controlled via lockable sliding doors.

To order please contact us on **01506 430309**/[www.empteezy.co.uk](http://www.empteezy.co.uk)

#### RACKSTOR

- Will hold up to twelve 1m x 800mm pallets or eight 1.2m x 1m pallets
- Equally spaced beams provide 2.7m space between the uprights
- Uniform Distributed Load is 2.6 tonne per bay, 10.4 tonne per unit
- Adjustable racking is bolted to the units frame to provide flexible storage options
- Large lockable sliding doors for easy access by fork lift truck
- No planning permission required
- No special foundations required.



STANDARD COLOUR: GREEN RAL 6029

#### RACKSTOR SECURE DRY GOODS STORE

All our prices include delivery to a mainland UK address

MODEL	EXTERNAL L x W x H	INTERNAL L x W x H	CAPACITY	TARE WEIGHT	DELIVERED PRICE
RS6M	5920 x 1500 x 3400mm	5260 x 1240 x 3000mm	8 x 1.2m x 1m or 12 x 1m x 800mm pallets	1400kg	£5863.00

# DRUM & IBC STORAGE/STEEL PRODUCTS

## SECURE WALK-IN STORE

### FULLY ENCLOSED

Protecting plant, tools and other expensive equipment is made easy with these robust steel, welded units.

For advice on secure storage please contact us on **01506 430309/advice@empteezy.co.uk**



### SECURE STORE

- 3 sizes available, ideal for securing equipment overnight on un-manned sites
- An all welded steel construction with a steel floor for added security
- Door opening 2m x 750mm clear space
- 2 point rod and lever locking handle system supported by a security hasp and staple fitting (padlock not provided)
- Crane lifting points fitted to the ends of the apex style roof which sheds rainwater.



HASP & STAPLE SECURITY COVER



LOCKING ROD LEVER ACTION HANDLE

STANDARD COLOUR: GREEN RAL 6029

### SECURE WALK-IN STORE

All our prices include delivery to a mainland UK address

MODEL	EXT L x W x H	INT L x W x H	TARE WEIGHT	DELIVERED PRICE
SS1	2190 x 2320 x 2284mm	2080 x 2156 x 2100mm	560kg	£2712.00
SS2	2990 x 2320 x 2284mm	2880 x 2156 x 2100mm	610kg	£3216.00
SS3	3790 x 2320 x 2284mm	3680 x 2156 x 2100mm	660kg	£3710.00

# DRUM & IBC STORAGE/STEEL PRODUCTS FLAT PACK SELF-BUILD STORES WITH WOODED FLOORS

Tools, machinery, games equipment etc. are all expensive commodities that unless secured when not in use will quickly disappear!!!

To order please contact us on **01506 430309**/[www.empteezy.co.uk](http://www.empteezy.co.uk)

## UNITS FOR SELF-ASSEMBLY

### SECURE ECONOMY STORES

- Available in blue powder coat paint finish
- Two 64mm Euro deadlocks with replaceable cylinders and a central roller catch
- 18mm thick timber plank boarding floor screwed to a galvanised steel profile frame
- Roof has two integral gutters for effective rainwater dispersal to all four corners of the unit
- A framework is bolted to the chassis and the panels and roof are in turn bolted to the frame
- 4 x12mmØ rods are used to connect the roof to the chassis and are used as lifting points for the unit.



### ACCESSORIES

- 1m 3 shelves kit £235
- 1.9m 3 shelves kit £385

### NOTE

- Full "how to build" instructions are supplied with each unit
- Pre-built option available, please contact us to discuss.



Doors are fitted in the width side of units

## FLAT PACK SELF-BUILD STORES

All our prices include delivery to a mainland UK address

MODEL	SIZE L x W x H	TARE WEIGHT	DELIVERED PRICE
MCL211	2140 x 2075 x 2140mm	352kg	£1516.00
MCL311	3060 x 2140 x 2140mm	400kg	£1830.00
MCL411	4050 x 2140 x 2140mm	500kg	£2457.00

# DRUM & IBC STORAGE/STEEL PRODUCTS TAILORED SOLUTIONS WE BUILD TO SUIT YOUR SPECIFIC APPLICATION

When you want a store to suit your particular needs, whether that be to fit a specific space or a unique layout, look no further, just tell us what you want and we will design, build and install it for you.

For advice on custom designed please contact us on **01506 430309/advice@empteezy.co.uk**



## TAILORED SOLUTIONS

- You may think it's complicated but it's not
- You tell us what you want to store, drums/IBC's of liquid, cylinders of special gasses, hazardous powders, temperature sensitive products, dry goods etc.
- You tell us where you want the store located and how you want to access it
- We carry out an assessment of the site
- We provide a report, drawings and of course a quotation and you have the information to make your decision with confidence.

## ADDITIONAL INFORMATION

- Typically there is no need for planning permission
- We don't use sub contractors only our own fully trained staff
- A schedule of works is agreed at the start of the project
- All work guaranteed.



# DRUM & IBC STORAGE/STEEL PRODUCTS

## COMPOUNDS

### CUSTOM DESIGNED, BUILT & INSTALLED

When looking to store large amounts of drums and or IBC, it can be impractical if they are spread across different units. Our "Compounds" provide the ideal solution.

To order please contact us on **01506 430309**/[www.empteezy.co.uk](http://www.empteezy.co.uk)

#### COMPOUNDS

- We offer 3 standard models capable of storing 64 to 96 x 205ltr drums or 16 to 24 x 1000ltr IBC's
- We can also build them to almost any size or configuration
- Our roofing system (extruded aluminium frame with double skinned polycarbonate sheets) is designed to maximum natural light and provide a safe working height for fork lift trucks
- Construction is to a very high specification using 80 x 80mm rolled hollow section steel for the framework and corrugated mild steel infill panels
- All sumps are fully seam welded and fully compliant with the 25% of the combined total stored rule.



#### ADDITIONAL INFORMATION

- Standard access is via sliding steel doors but we also offer hinged or roller shutters to suit your requirements
- Internal storage bays are not normally fitted with doors but if bays require heating/temperature control to protect the contents we would advise that they are
- The space in the centre of a standard compound is not normally protected by a sump but we can supply one if required by your specification
- Planning permission should not be required but we would strongly recommend that you confirm this with your local authority before any project is started.



EXAMPLE OF A CUSTOMIZED COMPOUND

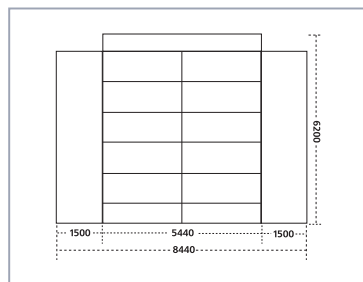

DC64

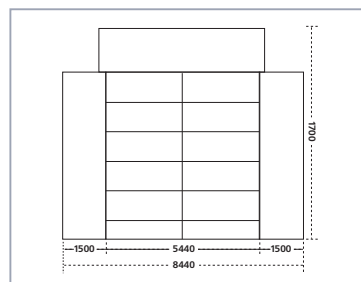

DC96

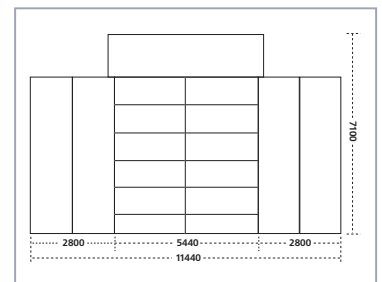

DC160

#### COMPOUNDS

All our prices include delivery to a mainland UK address

MODEL	DRUMS	DESCRIPTION	SIZE L x W x H	SUMP	DELIVERED PRICE
DC64	64	2 twin compartment 2 tier units facing each other with a central roof back wall and double sliding access doors – 16 pallets	8760 x 6520 x 4800mm	3780ltr	POA
DC96	96	3 twin compartment 2 tier units configured in a horseshoe with a central roof and double sliding access doors – 24 pallets	8760 x 7420 x 4800mm	5670ltr	POA
DC160	160	2 double twin 2 tier compartments with push back loading and 1 twin 2 tier compartment in a horse shoe configuration with a central roof and double sliding access doors – 40 pallets	11760 x 7420 x 4800mm	7560ltr	POA

# DRUM & IBC STORAGE/STEEL PRODUCTS TEMPERATURE CONTROL SYSTEMS TO SAFEGUARD SENSITIVE LIQUIDS

Many liquids are temperature sensitive requiring specific temperatures to be stored or used in, this page shows examples of how we can help you protect and store your products.

For advice on temperature control please contact us on [01506 430309](tel:01506430309)/[advice@empteezy.co.uk](mailto:advice@empteezy.co.uk)



## **REFRIGERATED UNITS**

- Specifically for refrigerating and controlling low temperature ranges
- Tell us the minimum and maximum temperature range you require.

## **OVEN UNITS**

- Specifically for heating and controlling a heat range
- Tell us the minimum and maximum temperature range you require
- Available with steam or electrical heating.



## **TEMPERATURE CONTROLLED UNITS**

- These units allow you to combine heating and cooling in one unit
- Tell us the minimum and maximum temperature range you require.

## **ADDITIONAL INFORMATION**

- Optional audio and/or visual alarm systems can be fitted to any unit or connected to your Building Management System
- Automatic extraction devices available
- Every unit is built specifically to your specification
- No obligation, free of charge site assessment is recommended.



# DRUM & IBC STORAGE/STEEL PRODUCTS

## RELOCATABLE GAS CYLINDER STORAGE

Ensuring that your gases are safely, securely and correctly stored is as important as your liquid storage.

To order please contact us on **01506 430309**/[www.empteezy.co.uk](http://www.empteezy.co.uk)

### GAS CYLINDER STORES

- We can colour code your unit to suit the gases you are storing, this can be useful when you have numerous gases and need to ensure correct segregation
- All models are fitted with fork pockets to aid unloading and location on site
- Our standard finish is Green RAL 6029
- All models are fitted with retaining straps or chains (not applicable on CT2LP).

#### CT1

- Mainly for internal use this unit allows you to keep up to 8 large cylinders together
- Fitted with a handy access ramp that doubles as a security device (can be padlocked) to deter unauthorised movement of individual cylinders.

#### CT2

- For indoor or outdoor use, this unit is enclosed on three sides and roofed
- Access is via a drop down loading ramp and hinged steel mesh door
- The unit is "gapped" around the base and roof to aid ventilation
- Can hold up to 8 cylinders.

#### CT2LP

- Built to the same specification as CT2, this unit is fitted with a shelf suitable for smaller cylinders or bottles
- Can hold up to 12 cylinders/bottles.

#### GB30

- This unit can hold up to 27 cylinders in compartments fitted with securing chains
- The twin hinged mesh doors allow you to control who has access
- A detachable steel ramp is included with this model to aid loading and unloading.



SHOWN IN NON STANDARD RED



STANDARD COLOUR: GREEN RAL 6029

### GAS CYLINDER STORAGE

All our prices include delivery to a mainland UK address

MODEL	SIZE L x W x H	CYLINDER QTY & SIZE	TARE WEIGHT	DELIVERED PRICE
CT1	1280 x 780 x 920mm	8 x 285mmØ (Vertical)	100kg	£1087.00
CT2	1280 x 780 x 2200mm	8 x 285mmØ	168kg	£1383.00
CT2LP	1280 x 780 x 2200mm	6 x 11kg per level	180kg	£1550.00
GB30	3000 x 1500 x 2256mm	27 x 285mmØ	550kg	£3553.00



# DRUM & IBC STORAGE/STEEL PRODUCTS

## CHEMSTOR®

### INDOOR OR OUTDOOR STORES

Ideal for managing and controlling access to production liquids such as paints, lubricants, solvents etc.

For advice on liquid storage please contact us on **01506 430309/advice@empteezy.co.uk**



#### CHEMSTOR®

- Manage your stock, control who has access and still ensure liquids are correctly stored to minimise leaks, spills and pollution incidents
- This range of 3 units are ideal as they are robust, have fully seam welded sumps that comply with the 25% of the total of the containers stored rule and are fitted with locks as standard.

#### NOTE

- Highly flammable liquids have limitations on the quantities that can be stored/placed upon them in terms of location. We are happy to advise you on this matter but would also suggest that independent advice be sought from your insurer, local authority fire brigade and the HSE.

#### ADDITIONAL INFORMATION

- All units have galvanised removable grid decks above the sump area, which in turn is raised on either fork hoops or base plinths dependent on the model to eliminate contact with the ground
- High and low level vents with flame arrester protection are fitted as standard to provide natural ventilation
- Construction of all 3 models uses robust steel frames with 2mm steel panels welded on to give additional strength and doors are either hinged or sliding dependent on the model.



STANDARD COLOUR: GREEN RAL 6029

#### CHEMSTOR® STORES

All our prices include delivery to a mainland UK address

MODEL	25LTR CANS	DESCRIPTION	SIZE L x W x H	SUMP	TARE WEIGHT	DELIVERED PRICE
CS3	80+5ltr shelf	Twin sliding doors 3 shelves + grid mesh	3000 x 1500 x 2450mm	1125ltr	1048kg	£4044.00
CS4	48	Twin sliding doors 2 shelves + grid mesh	2500 x 800 x 2350mm	450ltr	600kg	£2016.00
CS5	20	Double hinged lockable doors shelves for 5ltr/25ltr cans	1500 x 750 x 1550mm	260ltr	240kg	£1190.00

# DRUM & IBC STORAGE/STEEL PRODUCTS

## CHEMSTOR®

### INDOOR OR OUTDOOR STORES

These "walk-in" stores are designed to let you safely store and if required work\* with liquids in the safe knowledge that the entire area is contained by a fully seam welded sump.

To order please contact us on **01506 430309**/[www.empteezy.co.uk](http://www.empteezy.co.uk)

#### CHEMSTOR®

- Each unit is fitted with industrial racking as standard and has high and low level vents with flame arresters to provide protected natural ventilation
- Construction is based on a rolled hollow section frame with steel panels welded to it for strength and durability
- The hinged access door on each model is fitted with a "cam-lock gear" system like those found on shipping containers, which when fitted with the appropriate padlock (not supplied) helps ensure excellent security.

\*If staff are to work in a unit, mechanical ventilation will be required. Please contact us for advice.

**20<sup>yr</sup> STRUCTURE GUARANTEE**



SHOWN IN NON STANDARD RED



STANDARD COLOUR: GREEN RAL 6029

#### CHEMSTOR® STORES

All our prices include delivery to a mainland UK address

MODEL	25LTR CANS	DESCRIPTION	SIZE L x W x H	SUMP	TARE WEIGHT	DELIVERED PRICE
CS1	72 including floor under shelving	Single bulk head door 775mm wide – cam gear lock – 2 sets of double shelves	2160 x 2160 x 2600mm	650ltr	660kg	£3100.00
CS2	72 including floor under shelving	Single bulk head door 1250mm wide – cam gear lock – 2 sets of double shelves	3000 x 2440 x 2600mm	1098ltr	1582kg	£3460.00
CS6	108 including floor under shelving	Single bulk head door 1250mm wide – cam gear lock – 3 sets of double shelves	5920 x 2440 x 2600mm	2196ltr	2200kg	£8119.00

# DRUM & IBC STORAGE/STEEL PRODUCTS ELECTRICAL & NON-ELECTRICAL OPTIONS

Heating and lighting is available for a wide range of our units, we offer both in standard commercial or zone 1 configuration.

For further information please contact us on [01506 430309](tel:01506430309)/[advice@empteezy.co.uk](mailto:advice@empteezy.co.uk)

## ELECTRICAL

### ELECTRICAL ZONE 1 LIGHTING FOR CS1, CS2 OR DPU16-4

- The unit is fitted with Zone one or Ex11 2GD, EExed 11c T4 1500mm single fluorescent light wired through a suitable 16A D.PEEExd T6 IP 66 light switch mounted beside the shelf unit/door, maximum load is 2.15amps. Termination within an externally mounted IP 65 rated enclosure, which is complete with a suitable isolator and M.C.B. All internal wiring is MICC cable with RGM glands and RPS seals.

### ELECTRICAL ZONE 1 LIGHTING FOR CS6 OR DPU32-8

- The unit is fitted with two Zone one Ex11 2GD, EExed 11c T4 1500mm single fluorescent light wired through a suitable 16A D.PEEExd T6 IP 66 light switch mounted beside the shelf unit/door, maximum load is 2.15amps. Termination within an externally mounted IP 65 rated enclosure, which is complete with a suitable isolator and M.C.B. All internal wiring in container in MICC cable with RGM glands and RPS seals.

### ELECTRICAL COMMERCIAL STANDARD LIGHTING FOR CS1, CS2 OR DPU16-4

- 1 x 5ft fluorescent light wired to a suitable metal clad light switch which is mounted beside the door or shelves. Wiring is run through PVC conduit tube to an IP rated box on the left-hand rear corner of the container. The IP65 box is mounted at high level and is complete with a suitable isolator and M.C.B.

### ELECTRICAL COMMERCIAL STANDARD LIGHTING FOR CS6 OR DPU32-8

- 2 x 5ft fluorescent lights wired to a suitable metal clad light switch which is mounted beside the door or shelves. Wiring is within PVC conduit tube to an IP rated box on the left-hand rear corner of the container. The IP65 box is mounted at high level and is complete with a suitable isolator and M.C.B.

### ELECTRICAL ZONE 1 HEATING FOR CS1 OR CS2

- The unit is fitted with one Zone One EExe T3 IIC CENELEC EN50 014, EN50 019, 1.5kw heater, maximum load is 6.25amps and is wired through a 0 to 20°C thermostat, which is EExd IIC T6, CENELEC EN50 014, EN50 018. All the internal wiring is MICC cable with RGM glands and RPS seals and termination is within an externally mounted IP65 rated enclosure, which is fitted with a suitable isolator & M.C.B.

### ELECTRICAL ZONE 1 HEATING FOR DPU16-4

- The unit is fitted with one Zone one EExe T3 IIC CENELEC EN50 014, EN50 019, 1kw heater, maximum load is 6.25amps and is wired through a 0 to 20°C thermostat, which is EExd IIC T6, CENELEC EN50 014, EN50 018. All the internal wiring is MICC cable with RGM glands and RPS seals and termination is within an externally mounted IP65 rated enclosure, which is fitted with a suitable isolator & M.C.B.

Please contact us to discuss your requirements and prices



LIGHTING



ZONE 1 HEATER



EXTRA LARGE VENTS

# DRUM & IBC STORAGE/STEEL PRODUCTS ELECTRICAL & NON-ELECTRICAL OPTIONS

You can modify your unit to suit your needs. Included below are some non-electrical options.

To order please contact us on **01506 430309**/[www.empteezy.co.uk](http://www.empteezy.co.uk)

## **ELECTRICAL ZONE 1 HEATING FOR CS6**

- The unit is fitted with two Zone one EExe T3 IIC CENELEC EN50 014, EN50 019, 1.5kw heaters, maximum load is 6.25amps and are wired through a 0 to 20°C thermostat, which is EExd IIC T6, CENELEC EN50 014, EN50 018. All the internal wiring is MICC cable with RGM glands and RPS seals and termination is within an externally mounted IP65 rated enclosure, which is fitted with a suitable isolator & M.C.B.

## **ELECTRICAL ZONE 1 HEATING FOR DPU32-8**

- The unit is fitted with three Zone one EExe T3 IIC CENELEC EN50 014, EN50 019, 1kw heaters, maximum load is 6.25amps and are wired through a 0 to 20°C thermostat, which is EExd IIC T6, CENELEC EN50 014, EN50 018. All the internal wiring is MICC cable with RGM glands and RPS seals and termination is within an externally mounted IP65 rated enclosure, which is fitted with a suitable isolator & M.C.B.

## **ELECTRICAL COMMERCIAL STANDARD HEATING FOR CS1, CS2 OR DPU16-4**

- The unit is fitted with one 1.5kw heater with a centrally mounted 0 to 20°C thermostat the wiring runs through PVC conduit tube to an IP65 rated box situated at high level on the left-hand rear corner of the unit, complete with suitable isolator and M.C.B.

## **ELECTRICAL COMMERCIAL STANDARD HEATING FOR CS6 OR DPU48-12**

- The unit is fitted with two 1.5kw heaters with a centrally mounted 0 to 20°C thermostat the wiring runs through PVC conduit tube to an IP65 rated box situated at high level on the left-hand rear corner of the unit, complete with suitable isolator and M.C.B.

Please contact us to discuss your requirements and prices



HIGH AND LOW LEVEL VENTS



FIRE SUPPRESSION SYSTEM



## **NON-ELECTRICAL**

### **ENTRANCE RAMP**

- A removable steel entrance ramp to provide ease of access when using a trolley to load/unload the unit.

### **SOLID FLOOR**

- Chequer plate flooring fitted between the shelves to provide ease of use for trolleys.

### **INSULATION**

- Consists of double skinning the unit. Steel panels are fitted internally to the roof, doors, sides and back panels. 50mm Rockwool insulation is secured between the inner and outer skins. Insulation is used to help maintain an internal ambient temperature.

### **FIRE SUPPRESSION**

- Consist of a pressurised extinguishing gas activated by the "Firetrace" Tubing. Placed within an enclosed area above potential fire hazards and secured in place with brackets. Extinguishing gases can be matched to the particular application. Various gas cylinder sizes are available and are supplied attached to the "Firetrace" Tubing. The cylinder(s) containing the gas are kept in a lockable cabinet fitted on the side of the unit. Fire suppression systems are fitted by qualified fitters and are certified as such.

### **SUMP EPOXY COATING**

- Epoxy coating can be applied to the sumps when storing aggressive products. Please advise the product to be stored for confirmation of suitability and price.



# ACCESSORIES



# BEST BUYS

The simple way to turn full 205lt drums from the vertical to the horizontal or vice versa, from the safety of your fork lift truck and at only £1014.00 HDFI will pay for itself in no time – SEE PAGE 96



Hiring a crane for a small lifting job can be expensive but our crane attachment CJF1 (2 versions available) is priced at £988.00 and couldn't be simpler to use – SEE PAGE 97



At only £289.00 trolley DTRW is easy to use and has the advantage of an additional set of wheels which make moving drums up and down kerbs etc very easy – SEE PAGE 98



Keep your outside space clean and tidy and cigarette end free. The Smokers Cease-Fire® is priced at £105.00 and comes in 5 standard colours, is weatherproof and because it will hold literally thousands of spent cigarette ends it won't overflow and become unsightly every few days – SEE PAGE 99



# ACCESSORIES FORK LIFT ATTACHMENTS FOR HANDLING DRUMS

When you need to switch drums from a vertical to a horizontal position or just move them around your site.

For advice on drum handling please contact us on [01506 430309](tel:01506430309)/[advice@empteezy.co.uk](mailto:advice@empteezy.co.uk)



## DRUM CLAMP

- DCS1 for 1 x vertical drum
- DCD2 for 2 x vertical drums
- Both models work with standard steel drums

## HOOK BEAK CLAMP

- PBS1 for 1 x vertical drum
- PBD2 for 2 x vertical drums
- Both models work with standard steel drums

## HINGED DRUM FORKS

- HDFI works with either closed head steel or L & XL plastic drums
- The practical solution to transferring drums from the vertical to the horizontal position.



## VERT DRUM TONGS

- TONGS/V works with either steel or L & XL plastic drums
- Suitable for use with overhead or truck mounted cranes or in conjunction with a fork attachment on a Fork Lift Truck
- Semi automatic operation

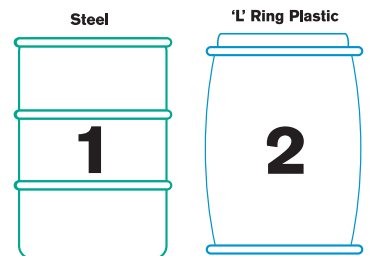

DOES NOT INCLUDE  
YELLOW FORK ATTACHMENT

## FORKLIFT ATTACHMENTS

All our prices include delivery to a mainland UK address

MODEL	DRUMS	DRUM SIZE	MAX LOAD	FORK SPREAD	MAX FORK SIZE	TARE WEIGHT	DELIVERED PRICE
DCS1	1	210ltr	500kg	560mm	140 x 55mm	53kg	£561.00
DCD2	2	210ltr	1000kg	880mm	140 x 55mm	80kg	£743.00
PBS1	1	210ltr	750kg	560mm	140 x 50mm	87kg	£1019.00
PBD2	2	210ltr	1500kg	560mm	140 x 50mm	100kg	£1671.00
HDFI	1	210ltr	400kg	567mm	140 x 50mm	105kg	£1014.00
TONGS/V	1	210ltr	500kg			22kg	£595.00

# ACCESSORIES

## FORK LIFT ATTACHMENTS

### CRANE & SAFE WORKING PLATFORM

Don't spend money on expensive equipment when you can utilise your Fork Lift Truck and quickly convert it as and when required.

To order please contact us on **01506 430309**/[www.empteezy.co.uk](http://www.empteezy.co.uk)

#### CRANE ATTACHMENTS

- CJF1 a fixed crane fitting tested to 33% overload to ensure safe use
- Safety swivel hook fitted as standard
- CJE2 a 4 position (horizontal) extending jib tested to 33% overload to ensure safe use
- Maximum reach 3050mm
- Safety swivel hook fitted as standard.



#### SAFE WORKING PLATFORM

- SWP1 single occupancy platform that complies with the Supply of Machinery (Safety) Regulations
- CE marked, carries a certificate of conformity and exceeds the recommendations of the HSE Guidance Note PM28
- Suitable for one person.

#### STANDARD FEATURES & OPTIONS

- Integrated safety harness "clip-on" rail, high back guard, checker plate floor and deep "kick plate" to reduce the risk of tools falling off
- Optional castors for ease of movement when not on Fork Lift Truck, Overhead Guard and a Tool Tray.



#### CRANE ATTACHMENTS

All our prices include delivery to a mainland UK address

MODEL	LENGTH	WIDTH	HEIGHT	MAX LOAD@ 610MM	MAX LOAD@ 3050MM	TARE WEIGHT	DELIVERED PRICE
CJF1	1940mm	690mm	420mm	3000kg	n/a	140kg	£988.00
CJE2	2100-3050mm	690mm	420mm	3000kg	484kg	216kg	£1290.00

#### SAFETY ACCESS PLATFORM

All our prices include delivery to a mainland UK address

MODEL	GATE POSITION	PLATFORM SIZE LxW	MAX FORK SIZE	FORK SPREAD	TARE WEIGHT	DELIVERED PRICE
SWP1	Left Side	1000 x 1220mm	150 x 50mm	700mm	106kg	£923.00

MODEL	DESCRIPTION	TARE WEIGHT	DELIVERED PRICE
SWP1 CASTORS	100mm castors	8kg	£124.00
SWP1 O/HEAD/GRD	Overhead guard	15kg	£163.00
SWP1 TOOL TRAY	Tool tray	6kg	£89.00



# ACCESSORIES

## DRUM TROLLEYS, DISPENSING & STORAGE FOR DRUMS & SMALL CONTAINERS

Move, store and dispense in a controlled and safe manner.

For advice on drum handling please contact us on [01506 430309](tel:01506430309)/[advice@empteezy.co.uk](mailto:advice@empteezy.co.uk)



STS/SS



DDEP

### DRUM DE-PALLETISER

- Compatible with standard pallets and spill pallets
- 2 speed hydraulic system
- Life time manufacturers guarantee
- Maximum safe working load 350kg.

### DISPENSING CRADLE

- For drums up to 30ltr in size
- Safety latch keeps drum in vertical position.

### BUNDED STORAGE RACK

- Self assembly system complete with all fittings
- Optional extras: Galvanised grid mesh and extra cross beams (pack of 2).



DCR130



BR1

### DRUM TROLLEYS

- DTRW 250mmØ solid rubber wheels
- Rubber handles for improved grip
- STS/SS only 20kg of force to lift 300kg
- Exceeds CE standard.



DTRW

#### STS™ D-PALLETISER

All our prices include delivery to a mainland UK address

MODEL	OVERALL H	OVERALL L	OVERALL W	MAX LIFT H	MAX PALLET H	TARE WEIGHT	DELIVERED PRICE
DDEP	1320mm	950mm	1200 Pallets (1620mm)	575mm	450mm	170kg	£3230.00

#### STAINLESS STEEL DRUM TROLLEY

All our prices include delivery to a mainland UK address

MODEL	MAX SWL	SPECIFICATION	OVERALL W	DRUM SIZE	TARE WEIGHT	DELIVERED PRICE
STS/SS	300kg	Ground clearance 75mm 300mmØ wheel	870mm	Max 210ltr Min 50ltr	35kg	£1014.00

#### TROLLEY

All our prices include delivery to a mainland UK address

MODEL	DESCRIPTION	SIZE L x W x H	CAPACITY	DELIVERED PRICE
DTRW	24kg drum truck - 250mmØ solid rubber wheels & rear wheel attachment	610x420x1520mm	270kg	£289.00

#### DISPENSING CRADLE

All our prices include delivery to a mainland UK address

MODEL	SIZE L x W x H	FINISH	WEIGHT	DELIVERED PRICE
DCR130	430 x 430 x 660mm	Painted mild steel	8kg	£160.00

#### BUNDED STORAGE RACKING

All our prices include delivery to a mainland UK address

MODEL	SIZE L x W x H	SUMP	WEIGHT SHELF	TARE WEIGHT	SUMP HEIGHT	DELIVERED PRICE
BR1	1996 x 950 x 1860mm	180ltr	600kg	148.5kg	120mm	£703.00
BR1 MESH	Galvanised mesh shelf			39kg		£125.00
BR1 BEAMSET	Beam x 2			38kg		£82.00

# ACCESSORIES

## SMOKERS CEASE-FIRE®

### FREE STANDING CIGARETTE BIN

One of the most common sights today is overflowing cigarette bins with cigarette ends strewn on the floor or filling plant pots. It makes your company look bad in the eyes of visitors and is normally down to the fact that most cigarette bins have a relatively small capacity.

For advice on smoking solutions please contact us on [01506 430309](tel:01506430309)/[advice@empteezy.co.uk](mailto:advice@empteezy.co.uk)

#### SMOKERS CEASE-FIRE®

- Apart from any other feature the main benefit of this product is its capacity
- The collection pail will hold hundreds, possibly thousands of cigarette ends meaning it does not need emptying very often and unless you totally neglect it you should not see unsightly cigarette ends on the floor
- The robust flame retardant, weather resistant polyethylene casing has a special design that starves the burning cigarette of oxygen so there is no need to stub it out
- The opening is designed to be large enough to take a cigarette or cigar end but not other litter.

#### 5 COLOURS TO CHOOSE FROM

Deco Black	Adobe Beige	Terracotta	Pewter Grey	Forrest Green
				



#### FREE STANDING CIGARETTE BINS

All our prices include delivery to a mainland UK address

MODEL	SIZE	COLOUR	WEIGHT	DELIVERED PRICE
26800D	420mmØ x 965mm	Deco Black	7kg	£105.00
26800B	420mmØ x 965mm	Adobe Beige	7kg	£105.00
26800T	420mmØ x 965mm	Terracotta	7kg	£105.00
26800	420mmØ x 965mm	Pewter Grey	7kg	£105.00
26800G	420mmØ x 965mm	Forrest Green	7kg	£105.00



# HAZARDOUS MATERIAL & FIRE RATED PRODUCTS



# BEST BUYS

---

Our range of DSEAR Dangerous Substances and Explosive Atmospheres Regulations 2002 compliant 1 hour fire rated units have been independently tested to give you complete confidence. CS2FR is a perfect example of a walk-in store that is robust, practical and cost effective at £7791.00 – SEE PAGE 106



A two door 3 shelf UK compliant laboratory cabinet from only £397.00 delivered to a mainland UK address – SEE HSC72/36 ON PAGE 110



Dispensing flammable liquids has never been safer or simpler with the Justrite range of plunger cans. Model 10208Z will hold 2ltr of liquid and is backed by a 10 year manufacturer's warranty. All this for only £65.00 – CHECK THE FULL RANGE ON PAGE 117



The danger of fire from waste rags used in the production process or maintenance is ever present, but if you use our Oily Waste Cans your problem will be solved in an instant. Their simple design keeps the rags safely away from the source of a fire so they can't fuel it. 09300 is a 34ltr foot operated can that will only cost you £95.00 – SEE PAGE 120



# HAZARDOUS MATERIAL & FIRE RATED PRODUCTS INTRODUCTION

For advice on handling flammable liquids please contact us on [01506 430309](tel:01506430309)/[advice@empteezy.co.uk](mailto:advice@empteezy.co.uk)

## REGULATION

- The safe storage of flammable liquids in process areas, workrooms, laboratories and similar working areas requires careful and informed consideration
- The Dangerous Substances and Explosive Atmospheres Regulations 2002 (DSEAR) require risks from the indoor storage of Dangerous Substances to be controlled by elimination or by reducing the quantities of such substances in the workplace to a minimum and providing mitigation to protect against foreseeable incidents.

## FIRE TRIANGLE

- There are 3 elements required for a fire to start:  
**HEAT – OXYGEN – FUEL**  
If you eliminate any one of these elements, you eliminate the fire
- **HEAT** Can be any ignition source which generates heat, such as a mechanical spark, static electricity, a lit match, cigarette/cigar etc.
- Effective control is achieved by the flame arresters and self-closing leak tight lids fitted to all our safety cans
- **OXYGEN & FUEL** Oxygen is all around us and fuel can be a flammable or combustible liquid
- Both are controlled by leak tight lids fitted with sealing gaskets that ensure fire can't get in and flammable vapours can't get out.

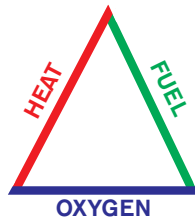

## REQUIREMENTS

- For practical purposes where flammable liquids are used, there is likely to be a need for a limited quantity to be stored in the working environment. It is the responsibility of the employer/duty holder when carrying out their risk assessment to justify the need to store any particular quantity of flammable liquid within the work room/working area
- However, the guiding principle is that only the minimum quantity needed for frequently occurring activities or an amount required for use during half a day or one shift should be present in the work room/working area
- Actual quantities will depend on the work activity and also the arrangements for controlling the fire risks
- When not in use, containers of flammable liquids needed for ongoing work activities should be kept closed and stored in suitable fire resistant cabinets or bins which are also designed to retain spills
- They should be located in designated areas that are where possible away from the processing area and so as not to interfere with the escape route from the working area
- The flammable liquids should be stored separately from other dangerous substances that may enhance the risk of fire or compromise the integrity of the container or cabinet/bin it's stored in; for example, oxidizers and corrosive materials should be separated. Remember other dangerous substances may also be flammable in their own right, however, it is still inappropriate to store these in the same cabinet/bin with flammable liquids. Further guidance on energetic and spontaneously combustible substances is contained in HS(G)131 published by the HSE.



# HAZARDOUS MATERIAL & FIRE RATED PRODUCTS

To order please contact us on **01506 430309**/[www.empteezy.co.uk](http://www.empteezy.co.uk)

## RECOMMENDATIONS

- The H.S.E. recommends that the maximum quantities that are stored in cabinets/bins are no more than 50ltr for extremely flammable, highly flammable and those flammable liquids with a flashpoint below the maximum ambient temperature 30°C of the working area; and no more than 250ltr for other flammable liquids with a higher flashpoint of up to 55°C
- These quantities are intended to be viewed as recommended maximums and represent good industry safe practice, rather than being taken as the absolute limits.

## GUIDANCE

- There can be some flexibility with the limits of the quantities stored, where it is understood that the design of the building and or the pattern of work can sometimes make adherence to these quantities difficult. For example, in large or open-plan working areas. However, where the employer/duty holder does identify a need to store quantities in excess of the recommended maximum, they must fully demonstrate the need for this requirement and in particular the risk assessment should take into account: The properties of the materials to be stored or handled (For mixed storage the worst case situation should be applied, i.e. all materials in the storage cabinets or bin should be considered as being as dangerous as the one that has the lowest flashpoint)
- The size of the workroom/working area and the number of people working in it
- The amount of flammable liquids being handled in the working area and the quantities of liquid that may be accidentally released or spilled
- Ignition sources and potential fire spread in the event of an ignition
- Exhaust ventilation provision to the working area and or the storage cabinets or bin
- The fire performance of the storage cabinet or bin. See pages 101 to 118 for our full range of FM approved, UK specification and EN 90 minute cabinets and bins
- The arrangements for closing the cabinet or bin door/lid in the event of a fire
- Means of escape from the working area.

## OBJECTIVE

- In the event of an incident the objective is to ensure that people can safely escape from the working area and in this context, the purpose of storing Dangerous Substances in the appropriate cabinets/bins is to provide a physical barrier to delay the involvement of the stored materials in a fire and provide sufficient time for people's safe evacuation and the duty holder's immediate emergency procedures supporting this to be implemented
- It is the responsibility of the employer/duty holder to ensure that cabinets/bins meet the minimum legal requirements. Equally, the use of cabinets/bins with enhanced fire performance should not be seen as a substitute for the provision of a dedicated store room(s) and outdoor storage areas for the safe keeping of containers which are nominally empty or are not needed for current work.

## CONTACT US

- Contact us today, arrange a site survey and reduce the risk of you and your company being liable to prosecution Tel 01506 430309 or email [advice@empteezy.co.uk](mailto:advice@empteezy.co.uk)

## PRODUCTS

- It's important not to overlook any aspect associated with the safe handling of flammable liquids. Static discharge during filling/decanting, combustion due to excessive heat build-up, potential ignition source such as a spark from a tool or electrical component and pressure build-up in a container.



- 1 ANTI-STATIC WIRES: PAGE 116**
- 2 SAFETY VENTS: PAGE 116**
- 3 SELF CLOSING SAFETY TAPS: PAGE 115**
- 4 TAP EXTENSIONS: PAGE 115**
- 5 SAFETY CANS: PAGES 106-109**

# HAZARDOUS MATERIAL & FIRE RATED PRODUCTS ADVICE ON STORAGE

The regulations covering the storage of hazardous materials are rigorous and strict and you need to understand them as they apply to your specific circumstances.

For advice on liquid storage please contact us on [01506 430309](tel:01506430309)/[advice@empteezy.co.uk](mailto:advice@empteezy.co.uk)

## HAZARDOUS MATERIALS

- In support of our standard range of units we are able to offer products that comply with a variety of regulations
- We offer a comprehensive range of units for flammable liquids from laboratory cabinets to 6m walk-in stores with fire rating times up to 90 minutes as standard.

## ADVICE

- To start the process of helping you select the correct product to suit your situation we will need to know the following; what volume and quantity of product you want to store and the proposed location. We will also need copies of the Material Safety Data Sheets
- We would normally recommend a visit to site, this carries no onus, cost or obligation on your part
- We also strongly recommend that you take independent advice from your insurers, local authority fire brigade and the HSE.

## DEFINITION OF FLAMMABLE LIQUIDS

- In general terms it is a liquid which has a flash point of 55°C or below
- The three main categories are flammable, highly flammable and extremely flammable.

## FLAMMABLE LIQUIDS

- Liquids with a flash point equal to or greater than 21°C and less than or equal to 55°C, which supports combustion when tested at 55°C.

## HIGHLY FLAMMABLE LIQUIDS

- Liquids with a flash point lower than 21°C but are not classified as extremely flammable.



## EXTREMELY FLAMMABLE LIQUID

- Liquids with a flash point lower than 0°C and with a boiling point lower than or equal to 35°C.



## PUBLICATIONS

- Storage of flammable liquids in containers HSG51  
Ordering code ISBN 0717614719
- Safe use and handling of flammable liquids HSG140  
Ordering code ISBN 0717609677
- The Dangerous Substances and Explosive Atmospheres Regulations 2002  
Ordering code: ISBN 011 0429575
- Storage of Dangerous Substances L.135  
Ordering code ISBN 0-7176-2200-2
- Control and Mitigation Measures L.136  
Ordering code ISBN 0-7176-2201-0
- Chemical Warehousing the Storage of Packaged Dangerous Substances HSG71  
Ordering code ISBN 97807 176 14844
- All publications are available on line from: [www.hsebooks.com/books](http://www.hsebooks.com/books).

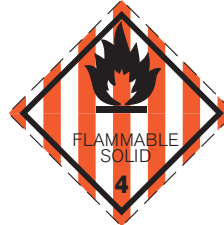

**COMPRESSED GASES**

 FLAMMABLE GAS 2	 COMPRESSED GAS 2	 TOXIC GAS 2
FLAMMABLE	NON FLAMMABLE/ NON TOXIC	TOXIC

**FLAMMABLE SOLIDS**

 FLAMMABLE SOLID 4	 SPONTANEOUSLY COMBUSTIBLE 4	 DANGEROUS WHEN WET 4
READILY COMBUSTIBLE	SPONTANEOUSLY COMBUSTIBLE	DANGEROUS WHEN WET

**OXIDISING SUBSTANCES**

 OXIDISING AGENT 5.1	 ORGANIC PEROXIDE 5.2
OXIDISING SUBSTANCES	ORGANIC PEROXIDE

**TOXIC SUBSTANCE**



TOXIC  
6

**CORROSIVE SUBSTANCES**



CORROSIVE  
8

**FLAMMABLE LIQUIDS**



FLAMMABLE LIQUID  
3

# HAZARDOUS MATERIAL & FIRE RATED PRODUCTS

## STORAGE VAULTS FOR CHEMICAL & FLAMMABLE PRODUCTS

These highly secure units are ideal for storing smaller quantities of liquid.

To order please contact us on **01506 430309**/[www.empteezy.co.uk](http://www.empteezy.co.uk)

### STORAGE VAULTS

- Fully compliant with all regulations for the safe storage of chemicals and flammables
- Fitted with robust 5-lever deadlocks with anti-drill plates on both sides
- Fully welded sump will contain leaks and spills
- Units are manufactured to a 30 minute fire resistance
- Finished in bright red with relevant hazard warning signs fitted as standard



### STORAGE VAULTS

MODEL	SIZE L x W x H	TARE WEIGHT	COLOUR	DELIVERED PRICE
FCSB21	760 x 675 x 665mm	50kg	Red	£772.00
FCSB2	1275 x 675 x 665mm	80kg	Red	£845.00
FCSC2	760 x 675 x 1275mm	95kg	Red	£917.00
FCFS5	1585 x 675 x 1275mm	200kg	Red	£1064.00
FCFS8	2400 x 1000 x 1275mm	350kg	Red	£2307.00

All our prices include delivery to a mainland UK address



# HAZARDOUS MATERIAL & FIRE RATED PRODUCTS

## 1 HOUR FIRE RATED STORES

### WALK-IN & FORK LIFT ACCESS

The components used in the manufacture of these units have been tested in conjunction with an independent test house (Bodycote Warrington) to ensure compliance with: BS EN 1634-1: 2000 (Report/Certificate N° 160129).

For advice on liquid storage please contact us on [01506 430309](tel:01506430309)/[advice@empteezy.co.uk](mailto:advice@empteezy.co.uk)

#### INDEPENDENT FIRE RATED TEST



- To give you further and complete confidence in Empteezy we have tested the components used in the manufacture of our fire rated stores in conjunction with the independent test house, Bodycote Warringtonfire to ensure they comply with: BS EN 1634-1: 2000.
- A full copy of the test report is available upon request to anyone ordering one of our fire rated units or if you have any questions about the test, please contact one of our customer advisors.

#### FIRE RATED STORES

- 2 "walk-in" and 2 fork lift truck accessed stores, all built with materials to give a 1 hour fire rating to help protect the contents in the event of a fire.

#### CS2FR

- Walk-in style
- Holds up to 72 x 25ltr drums.

#### ADDITIONAL INFORMATION

- All units are constructed using a rolled hollow section frame which is "skinned" with steel sheets, in-filled with Rockwool Firebatt insulation to provide up to 1 hours fire rating and then an inner skin of steel sheet.
- The sumps are fully seam welded and comply with the 25% of the total number of containers stored rule and have removable galvanised steel grid mesh decks fitted as standard
- High and low level vents with flame arresters are fitted with intumescent elements which automatically seal in the event of a fire, at temperatures above 150°C.



**20<sup>YR</sup> STRUCTURE GUARANTEE**

STANDARD COLOUR: GREEN RAL 6029

#### FIRE RATED STORES

MODEL	CONTAINERS	DESCRIPTION	SIZE L x W x H	SUMP	TARE WEIGHT	DELIVERED PRICE
CS2FR	72 x 25ltr including floor space under shelves	Single central door 1060mm wide 2 sets of double shelves	3000 x 2440 x 2600mm	1080ltr	2116kg	£7791.00

All our prices include delivery to a mainland UK address

# HAZARDOUS MATERIAL & FIRE RATED PRODUCTS

## 1 HOUR FIRE RATED STORES

### WALK-IN & FORK LIFT ACCESS

Ensure compliance and store your drums, IBC or small containers in a UK compliant 1 hour fire rated store.

To order please contact us on **01506 430309**/[www.empteezy.co.uk](http://www.empteezy.co.uk)

#### CS6FR

- Walk-in style
- Holds up to 108 x 25ltr drums.

#### DPU16-4FR

- Fork lift access style
- Holds 16 x 205ltr drums or 4 x 1000ltr IBC's.

#### DPU32-8FR

- Fork lift access style
- Holds 32 x 205ltr drums or 8 x 1000ltr IBC's.



STANDARD COLOUR: GREEN RAL 6029

#### FIRE RATED STORES

All our prices include delivery to a mainland UK address

MODEL	CONTAINERS	DESCRIPTION	SIZE L x W x H	SUMP	TARE WEIGHT	DELIVERED PRICE
CS6FR	108 x 25ltr cans including floor space under shelves	Single door offset R/H side 1250mm wide 3 sets of double shelves	6000 x 2440 x 2600mm	2196ltr	3900kg	£15073.00
DPU16-4FR	16 x 205ltr drums or 4 x 1000ltr IBC	2 full sized hinged doors 1 central shelf	3000 x 1500 x 3275mm	1125ltr	2450kg	£8082.00
DPU32-8FR	32 x 205ltr drums or 8 x 1000ltr IBC	4 hinged doors 1 central shelf	5920 x 1500 x 3275mm	2100tr	3000kg	£13525.00

# HAZARDOUS MATERIAL & FIRE RATED PRODUCTS

## JUSTRITE® FM APPROVED CABINETS

These cabinets are Factory Mutual (FM) tested and approved and backed by a manufacturers 10 year warranty.

For advice on storage cabinets please contact us on 01506 430309/advice@empteezy.co.uk

### JUSTRITE® FM APPROVED CABINETS

- A recently published HSE document gives criteria whereby maximum recommended quantities of flammable liquids that may be stored (50/250ltr depending on flash point) may be exceptionally exceeded and the points that "need to be made" in the relevant risk assessment
- One point is "the fire performance of the storage cupboard" (cabinet)
- Examples are given of cabinets having "enhanced fire performance" and "more demanding standards and design specifications" which includes ones to "Factory Mutual" and American "ANSI/NFPA 30 Standards"
- The HSE state these cabinets are "not a legal requirement", however, they do say their use may "help in making" the "risk assessment" demonstratable. For the full text of the HSE document, go to [www.hse.gov.uk](http://www.hse.gov.uk) and type in the search box "storage of flammable liquids in working areas"

- Point 1**
- Minimal door to frame gaps better resist flame penetration
- Point 2**
- Sturdy 1mm steel double skin construction with 38mm cavities slows heat transfer to contents
- Point 3**
- Easy push to close self latching doors
- Point 4**
- Welded carcass produces a fire resistant rigid enclosure which resists thermal distortion and flame penetration
- Point 5**
- Piano hinges produce gap free smooth closing
- Point 6**
- Anti-static wire attachment point on external side wall
- Point 7**
- Flame arrested high/low level vents produce a scavaging diagonal air flow. Screw in blanking plugs are provided for non-venting applications
- Point 8**
- External and internal surfaces are finished with lead free hybrid powder coat to produce a durable chemical/corrosion
  - Resistant attractive finish
- Point 9**
- Adjustable levelling feet ensure accurate door/frame alignment
- Point 10**
- Unique SpillSlope safety shelves direct spilt liquid away from the doors and contains it within the cabinet. Manufactured from heavy gauge galvanised steel they are bi-directional and easily adjustable on 76mm centres for versatile storage.
  - Patent Pending
- Point 11**
- 51mm deep liquid tight spill containment sump
- Point 12**
- Welded shelf supports interlock with shelves and provide strong non slip stability. No flimsy clip brackets to lose!

- Point 13**
- Haz-Alert™ high visibility low level reflective hazard warning band alerts fire fighters crawling in smoke filled areas
  - Patent Pending
- Point 14**
- Unique U•Loc handle has barrel lock and keys plus provision for users own padlock.
  - This feature allows secondary security/individual/common key options. Flush lay flat paddle handle reduces the danger of snagging/damage by passing traffic and has easy fingertip slip resistant operation
  - Patent Pending
- Point 15**
- Three point 'easy slide' stainless steel self-latching system provides fail safe positive door closure. No low temperature melting point alloy metals are used
- Point 16**
- Haz-Alert high visibility reflective hazard warning signage in three languages is highly visible under fire/darkened conditions and illuminates by torchlight in total darkness. Patent Pending
- Point 17**
- Rounded safety corners on doors reduce risks of hand injury and nicks or cuts.



Point 9



Point 10



Point 13



Point 14



Point 16

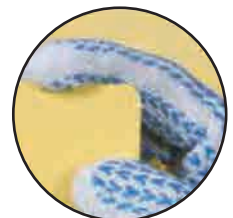

Point 17



Point 15

# HAZARDOUS MATERIAL & FIRE RATED PRODUCTS

## JUSTRITE® FM APPROVED CABINETS

### CABINETS

This range of flammable liquid cabinets will protect your flammable liquids and buy your staff time to either deal with a fire or evacuate the facility.

To order please contact us on **01506 430309**/[www.empteezy.co.uk](http://www.empteezy.co.uk)

#### FM APPROVED CABINETS

- Store daily working amounts of hazardous liquid on the shop floor
- Fully contained sump ensures any leaks are fully contained
- Ideal for use in laboratories/test facilities or the production line
- Please refer to the previous page for a full list of the features of these cabinets
- Internationally recognised Factory Mutual approval on all models.

#### NOTE

- This range exceeds the required legal standard for compliance in the UK.



OTHER SIZES AVAILABLE ON REQUEST

#### JUSTRITE® FM APPROVED CABINETS

All our prices include delivery to a mainland UK address

MODEL	CAPACITY	NO. OF DOORS	TYPE OF DOOR	DIMENSIONS L x W x H	NO. SHELVES	TARE WEIGHT	DELIVERED PRICE
8923001	83ltr	2	Manual	889 x 559 x 889mm	1	86kg	£974.00
8930001	114ltr	2	Manual	1092 x 457 x 1118mm	1	108kg	£1034.00
8945001	170ltr	2	Manual	1092 x 457 x 1651mm	2	141kg	£1270.00

# HAZARDOUS MATERIAL & FIRE RATED PRODUCTS

## UK STANDARD CABINETS

### FULLY COMPLIANT TO UK STANDARDS

The safety of staff and protecting the fabric of a building is of paramount importance to everyone, this range of cabinets help you comply with The Dangerous Substances and Explosive Atmospheres Regulations 2002.

For advice on storage cabinets please contact us on **01506 430309/advice@empteezy.co.uk**



HSC72/36



COSHH24/36



COSHH30/18



FS36/24

### FLAMMABLE LIQUID AND COSHH CABINETS

- Liquid tight sumps ensure spills are fully contained
- Adjustable shelves provide flexible storage
- Manufactured from 1mm thick sheet steel with a powder-coat paint finish.

### NOTE

- All models comply with current UK legislation
- Warning signage conforms to BS 5378
- Storage bin models are not supplied with padlocks

### YELLOW FLAMMABLE LIQUID & GREY COSHH CABINETS

All our prices include delivery to a mainland UK address

MODEL	MODEL	DESCRIPTION	EXTERNAL L x W x H	TARE WEIGHT	DELIVERED PRICE
Flammable	COSHH				
HSC18/18	COSHH18/18	Single door – 1 shelf – 1 tray	457 x 305 x 457mm	13kg	£152.00
HSC24/18	COSHH24/18	Single door cabinet – 1 shelf – 1 tray	457 x 457 x 609mm	19kg	£167.00
HSC24/36	COSHH24/36	Twin door cabinet – 1 shelf – 1 tray	915 x 457 x 609mm	31kg	£235.00
HSC30/18	COSHH30/18	Single door cabinet – 1 shelf	460 x 460 x 760mm	22kg	£179.00
HSC36/18	COSHH36/18	Single door cabinet – 1 shelf	460 x 460 x 915mm	25kg	£187.00
HSC24/24	COSHH24/24	Single door cabinet – 1 shelf	610 x 305 x 610mm	19kg	£204.00
HSC28/36	COSHH28/36	Twin door cabinet – 1 shelf	915 x 460 x 710mm	33kg	£252.00
HSC36/36	COSHH36/36	Twin door cabinet – 1 shelf	915 x 460 x 915mm	36kg	£272.00
HSC48/36	COSHH48/36	Twin door cabinet – 2 shelves	915 x 460 x 1220mm	53kg	£345.00
HSC60/36	COSHH60/36	Twin door cabinet – 2 shelves	915 x 460 x 1525mm	60kg	£378.00
HSC72/36	COSHH72/36	Twin door cabinet – 3 shelves	915 x 460 x 1830mm	72kg	£397.00

### FLAMMABLE LIQUID BINS – YELLOW

All our prices include delivery to a mainland UK address

MODEL	DESCRIPTION	EXTERNAL L x W x H	TARE WEIGHT	DELIVERED PRICE
HSFB20/24	Storage Bin – flat lid – hasp & staple for padlock – 1 tray	609 x 330 x 508mm	18kg	£157.00
HSB26/24	Storage Bin – sloping lid – hasp & staple for padlock	610 x 330 x 660mm	20kg	£251.00
HSB30/46	Storage Bin – sloping lid – hasp & staple for padlock	1170 x 460 x 760mm	43kg	£353.00

### FLAMMABLE STORE – RED

All our prices include delivery to a mainland UK address

MODEL	DESCRIPTION	EXTERNAL L x W x H	TARE WEIGHT	DELIVERED PRICE
FS36/24	Storage Bin – flat lid – hasp & staple for padlock	914 x 635 x 686mm	54kg	£442.00

Optional 455mm high stand available for each size of cabinet (except HSC72/36 and COSHH72/36) – please quote product code to ensure correct stand is supplied. Weight 10kg. Additional shelves can be ordered for all the cabinets, please quote product code.

# HAZARDOUS MATERIAL & FIRE RATED PRODUCTS

## UK STANDARD CABINETS

### FULLY COMPLIANT TO UK STANDARDS

Safe storage and easy identification of contents is aided when you use these colour coded cabinets.

To order please contact us on **01506 430309**/[www.empteezy.co.uk](http://www.empteezy.co.uk)

#### ACID AND ALKALI CABINETS

- Colour coded white and labelled with signage to BS 5378.

#### PESTICIDE AND AGROCHEMICAL CABINETS

- Vented doors and fitted with a spigot on the back panel to enable venting equipment to be attached
- Colour coded white and fitted with signage to BS 5378.

#### PETROLEUM CABINETS

- Manufactured from 1.6mm thick sheet steel
- Colour coded red and fitted with signage to BS 5378
- 3 point door closure and separate lock
- Perforated shelves.

#### NOTE

- All versions have liquid tight sumps and comply with current UK legislation.



#### ACID & ALKALI STORAGE CABINETS – WHITE

All our prices include delivery to a mainland UK address

MODEL	DESCRIPTION	EXTERNAL L x W x H	TARE WEIGHT	DELIVERED PRICE
AAC30/18	Single door cabinet – 1 Shelf	460 x 460 x 760mm	22kg	£224.00
AAC36/18	Single door cabinet – 1 Shelf	460 x 460 x 915mm	25kg	£274.00
AAC24/24	Single door cabinet – 1 Shelf	610 x 305 x 610mm	19kg	£284.00
AAC28/36	Twin door cabinet – 1 Shelf	915 x 460 x 710mm	33kg	£384.00
AAC36/36	Twin door cabinet – 1 Shelf	915 x 460 x 915mm	36kg	£405.00
AAC48/36	Twin door cabinet – 2 Shelves	915 x 460 x 1220mm	53kg	£432.00
AAC60/36	Twin door cabinet – 2 Shelves	915 x 460 x 1525mm	60kg	£476.00
AAC72/36	Twin door cabinet – 3 Shelves	915 x 460 x 1830mm	72kg	£617.00

#### PETROLEUM STORAGE CABINETS – RED

All our prices include delivery to a mainland UK address

MODEL	DESCRIPTION	EXTERNAL L x W x H	TARE WEIGHT	DELIVERED PRICE
PS36/36	Twin door cabinet – 2 mesh shelves, 1 mesh spill tank cover stand	915 x 457 x 1450mm including stand	50kg	£388.00
PS48/36	Twin door cabinet – 2 mesh shelves, 1 mesh spill tank cover stand	915 x 457 x 1750mm including stand	67kg	£432.00

#### PESTICIDE & AGROCHEMICAL STORAGE CABINETS – VENTED DOORS – RED

All our prices include delivery to a mainland UK address

MODEL	DESCRIPTION	EXTERNAL L x W x H	TARE WEIGHT	DELIVERED PRICE
PAC30/18	Single door cabinet – 1 Shelf	460 x 460 x 760mm	22kg	£188.00
PAC36/18	Single door cabinet – 1 Shelf	460 x 460 x 915mm	25kg	£213.00
PAC24/24	Single door cabinet – 1 Shelf	610 x 305 x 610mm	19kg	£235.00
PAC28/36	Twin door cabinet – 1 Shelf	915 x 460 x 710mm	33kg	£287.00
PAC36/36	Twin door cabinet – 1 Shelf	915 x 460 x 915mm	36kg	£309.00
PAC48/36	Twin door cabinet – 2 Shelves	915 x 460 x 1220mm	53kg	£395.00
PAC60/36	Twin door cabinet – 2 Shelves	915 x 460 x 1525mm	60kg	£428.00
PAC72/36	Twin door cabinet – 3 Shelves	915 x 460 x 1830mm	72kg	£450.00

For AAC and PAC models there are optional 455mm high stand available for each size of cabinet (except AAC72/36 and PAC72/36) – please quote product code to ensure correct stand is supplied. Weight 10kg. Additional shelves can be ordered for all the cabinets, please quote product code.

# HAZARDOUS MATERIAL & FIRE RATED PRODUCTS

## 90 MINUTE FIRE RATED CABINETS

### COMPLIANT WITH BS EN 14470-1

For the ultimate protection of your staff and property.

For advice on storage cabinets please contact us on **01506 430309/advice@empteezy.co.uk**



DOOR CLOSER



PERFORATED SHELVES



EN92-063-110



EN91-196-060



EN92-196-120

### 90 MINUTE FIRE RATED CABINETS

- 3 sizes of cabinets all manufactured to the same high standard, to give peace of mind to anyone storing and using flammable liquids.

### COMMON FEATURES

- Doors are fitted with hydraulic aided closers and heat activated triggers and in the event of a fire automatically close at a temperature of 50°C
- The adjustable shelves drain via a central hole to the sump which has a perforated cover on which containers can be placed
- The two large cabinets have a removable kick plate that gives access to the underside and allows movement by pallet truck. Adjustable feet are also located behind the kick plate, which allows you to level the unit in situ.

### 90 MINUTE FIRE RATED CABINETS

All our prices include delivery to a mainland UK address

MODEL	DESCRIPTION	EXTERNAL L x W x H	TARE WEIGHT	DELIVERED PRICE
EN91-196-060	Single door cabinet	600 x 595 x 1960mm	340kg	£1400.00
EN92-196-120	Twin door cabinet	1200 x 595 x 1960mm	600kg	£1800.00
EN92-063-110	Twin door cabinet under-bench	1100 x 550 x 635mm	340kg	£1250.00

# HAZARDOUS MATERIAL & FIRE RATED PRODUCTS

## TYPE I SAFETY CANS FOR FLAMMABLE LIQUIDS

This range of non-explosive safety cans gives you control over flammable liquids. Easy to fill and dispense from, the contents are protected by flame arresters and self-close, leak proof lids.

To order please contact us on **01506 430309**/[www.empteezy.co.uk](http://www.empteezy.co.uk)



### TYPE I STEEL CANS

- Designed with a single spout for filling and pouring
- Cans up to 1ltr size have a trigger release handle
- 4ltr and bigger cans have a swinging handle for easier carrying
- Factory Mutual approved.



### TYPE I POLYETHYLENE CANS

- Where compatibility with steel is an issue
- Resistant to tough acids and corrosives as well as heat
- Self close lid, pressure relief mechanism and duel density flame arrester
- Factory Mutual approved.



#### TYPE I CANS FOR FLAMMABLES

MODEL	DESCRIPTION	OUTER Ø & HEIGHT	TARE WEIGHT	DELIVERED PRICE
10001Z	0.5ltr safety can - red	117 x 172mm	1kg	£70.00
10101Z	1ltr safety can - red	117 x 210mm	1kg	£71.00
7110100Z	4ltr safety can - red	241 x 279mm	2kg	£60.00
7120100Z	7.5ltr safety can - red	241 x 349mm	2kg	£66.00
7125100Z	9.5ltr safety can - red	298 x 292mm	3kg	£69.00
7150100Z	19ltr safety can - red	298 x 429mm	4kg	£70.00
11202Y	Polypropylene funnel for use with steel cans 4ltr & above	13 x 286mm	0.5kg	£20.00

All our prices include delivery to a mainland UK address

#### TYPE I POLYETHYLENE CANS FOR FLAMMABLES

MODEL	DESCRIPTION	HARDWARE	EXTERNAL L x W x H	TARE WEIGHT	DELIVERED PRICE
14065Z	2ltr oval can - red	stainless steel	117 x 194 x 241mm	1kg	£87.00
14160Z	4ltr oval can - red	stainless steel	117 x 194 x 324mm	1kg	£88.00
14261	9.5ltr round can - red	stainless steel	273 x 362mm	2kg	£137.00
14561	19ltr round can - red	stainless steel	324 x 406mm	4kg	£170.00

All our prices include delivery to a mainland UK address



# HAZARDOUS MATERIAL & FIRE RATED PRODUCTS

## TYPE II STEEL SAFETY CANS FOR FLAMMABLE LIQUIDS

These cans will not explode under fire conditions.

For advice on flammable liquids please contact us on [01506 430309](tel:01506430309)/[advice@empteezy.co.uk](mailto:advice@empteezy.co.uk)



### TYPE II ACCUFLOW™ STEEL CANS

- Patented, innovative manifold automatically vents for smooth, plug free pouring
- Safe-Squeeze® trigger provides maximum control when pouring
- Stainless steel flame arrester dissipates heat to prevent flashback ignition.

### ADDITIONAL INFORMATION

- All Type II cans are Factory Mutual approved.

Ergonomic lift lever opens the self-close spout for easy filling. A full length stainless steel flame arrester dissipates heat and allows deeper, secure insertion of the nozzle when filling.



### TYPE II ACCUFLOW™ SAFETY CAN



### TYPE II ACCUFLOW™ CANS FOR FLAMMABLES

All our prices include delivery to a mainland UK address

MODEL	DESCRIPTION	OUTER Ø & HEIGHT	HOSE Ø & LENGTH	TARE WEIGHT	DELIVERED PRICE
7210120Z	4ltr safety can with hose - red	241 x 267mm	16 x 229mm	3kg	£114.00
7220120Z	7.5ltr safety can with hose - red	241 x 337mm	16 x 229mm	4kg	£115.00
7225130Z	9.5ltr safety can with hose - red	298 x 305mm	25 x 229mm	4kg	£119.00
7250130Z	19ltr safety can with hose - red	298 x 445mm	25 x 229mm	5kg	£124.00

# HAZARDOUS MATERIAL & FIRE RATED PRODUCTS

## LABORATORY CANS

### FOR FLAMMABLE LIQUIDS

When working in the confines of a laboratory/test facility having liquids "under your control" means you have one less thing to worry about and these cans are designed not to explode under fire conditions.

To order please contact us on **01506 430309**/[www.empteezy.co.uk](http://www.empteezy.co.uk)

#### LABORATORY CANS

- Designed specifically for use in the laboratory to make pouring hazardous liquids into test tubes, beakers and small flasks as safe as possible, the fill spouts have self-closing pressure relief caps and double mesh flame arresters
- The polyethylene version gives superb corrosion protection and a unique current carrying carbon insert embedded into the container allows for proper earthing
- All models are Factory Mutual approved.



#### LABORATORY CANS – RED

MODEL	DESCRIPTION	OUTER Ø & HEIGHT	TARE WEIGHT	DELIVERED PRICE
7225140	9.5ltr shelf can with 08540 tap	298 x 292mm	4kg	£166.00
7225150Z	9.5ltr shelf can with 08902 tap	298 x 292mm	4kg	£166.00
7150140	19ltr shelf can with 08540 tap	298 x 429mm	4kg	£174.00
7150150Z	19ltr shelf can with 08902 tap	298 x 429mm	4kg	£169.00
7150146	19ltr tilt can with 08540 tap & stand	298 x 403mm	6kg	£221.00
7150156	19ltr tilt can with 08902 tap & stand	298 x 403mm	6kg	£229.00
14545Z	19ltr poly shelf can with 08540 tap	298 x 432mm	5kg	£250.00

All our prices include delivery to a mainland UK address

# HAZARDOUS MATERIAL & FIRE RATED PRODUCTS

## WASTE CANS

### FOR CORROSIVE & COMBUSTIBLE SOLVENTS

These containers are designed with wide apertures to allow the safe collection of waste liquids.

For advice on these products please contact us on [01506 430309](tel:01506430309)/[advice@empteezy.co.uk](mailto:advice@empteezy.co.uk)



#### SELF-CLOSING CANS FOR CORROSIVES

- Manufactured from high-density “natural” polyethylene specifically developed to resist acids and caustics, the flame arrester free spout allows quick pouring of non-flammable corrosives. Translucent material allows you to see the liquid level in the container



#### LIQUID DISPOSAL CANS

- Designed for the safe collection of combustible solvents these cans have built-in flame arresters, wide openings to aid filling and automatic venting.



#### SELF-CLOSE WASTE CONTAINERS FOR NON-FLAMMABLE CORROSIVES

All our prices include delivery to a mainland UK address

MODEL	DESCRIPTION	OUTER Ø & HEIGHT	OPENING	TARE WEIGHT	DELIVERED PRICE
12161*	4ltr polyethylene oval container with stainless steel hardware	117 x 194 x 324mm	37mm	1kg	£78.00
12762*	7.5ltr wide mouth polyethylene container with stainless steel hardware	305 x 375mm	92mm	3kg	£220.00
12260*	9.5ltr wide mouth polyethylene container with stainless steel hardware	273 x 362mm	37mm	3kg	£139.00
12765*	19ltr wide mouth polyethylene container with stainless steel hardware	305 x 508mm	92mm	4kg	£231.00

\*Not fitted with a flame arrester.

#### LIQUID DISPOSAL CANS

All our prices include delivery to a mainland UK address

MODEL	DESCRIPTION	OUTER Ø & HEIGHT	TARE WEIGHT	DELIVERED PRICE
14265	7.5ltr red polyethylene can with stainless steel hardware & 08530 fill gauge	305 x 375mm	3kg	£202.00
14762Z	7.5ltr red polyethylene can with stainless steel hardware	305 x 375mm	3kg	£205.00
12751	7.5ltr white polyethylene can with stainless steel hardware	305 x 375mm	3kg	£166.00
14765Z	19ltr red polyethylene can with stainless steel hardware	305 x 508mm	5kg	£265.00
12754	19ltr white polyethylene can with stainless steel hardware	305 x 508mm	5kg	£231.00

# HAZARDOUS MATERIAL & FIRE RATED PRODUCTS

## LIQUID DISPENSING FOR FLAMMABLE LIQUIDS

The use of cleaning solvents to clean components can lead to incidents where relatively large amounts of liquid are spilled. These liquid dispensing systems allow you to have full control over the amount of liquid used.

To order please contact us on **01506 430309**/[www.empteezy.co.uk](http://www.empteezy.co.uk)

### PLUNGER CANS

- Made from chemically resistant Ryton® and brass, the new Blacktop "smart pump" is designed to drain the contents down to the last few ml so it needs refilling less often
- A simple and effective way to moisten cleaning cloths and ensure the liquid is fully under your control
- Place a cloth onto the perforated screen (which also acts as a flame arrester) depress the plunger and a controlled amount of liquid is released.

### DISPENSING BOTTLES

- Apply liquid directly on to the surface of the component in a controlled manor with a dispensing bottle
- The brass valves are self-closing and leak proof and the body of the bottle is contoured and textured to aid grip.

### ADDITIONAL INFORMATION

- Flame arresters are designed to prevent in the event of fire, flame from entering the can and causing it to explode
- All products apart from 14002 and 11171 are Factory Mutual tested and approved.



### BENCH CANS

- These products can be used to either moisten cloths or "wash" small components
- The mesh screen also acts as a flame arrester, while the hinged lid helps reduce evaporation.



### PLUNGER CANS

All our prices include delivery to a mainland UK address

MODEL	DESCRIPTION	DASHER	PLUNGER	DASHER Ø	OUTER Ø & HEIGHT	TARE WEIGHT	DELIVERED PRICE
10008	0.5ltr steel can	steel	brass & Ryton®	70mm	125 x 133mm	1kg	£55.00
10108Z	1ltr steel can	steel	brass & Ryton®	128mm	185 x 143mm	1kg	£67.00
10208Z	2ltr steel can	steel	brass & Ryton®	128mm	185 x 187mm	1kg	£65.00
10308Z	4ltr steel can	steel	brass & Ryton®	128mm	185 x 267mm	2kg	£75.00
14018Z	1ltr polyethylene can	brass	brass & Ryton®	128mm	141 x 210mm	1kg	£79.00

### BENCH CANS

All our prices include delivery to a mainland UK address

MODEL	DESCRIPTION	DASHER Ø	OUTER Ø & HEIGHT	TARE WEIGHT	DELIVERED PRICE
10175	1ltr steel can	108mm	124 x 140mm	1kg	£50.00
10295Z	2ltr steel can	191mm	238 x 83mm	2kg	£62.00
10375Z	4ltr steel can	191mm	238 x 114mm	2kg	£60.00
10575Z	8ltr steel can	248mm	292 x 149mm	4kg	£100.00
11171	Basket for 10375Z	n/a	175 x 22mm	0.2kg	£16.00

### POLYETHYLENE DISPENSING BOTTLES

All our prices include delivery to a mainland UK address

MODEL	DESCRIPTION	SPOUT OPENING	OUTER Ø & HEIGHT	TARE WEIGHT	DELIVERED PRICE
14002	0.12ltr dispenser bottle	6mm	57 x 140mm	1kg	£35.00
14004	0.24ltr dispenser bottle	6mm	79 x 140mm	1kg	£42.00
14010	1ltr dispenser bottle	6mm	102 x 267mm	1kg	£46.00
14009	0.5ltr bottle with flex tube	n/a	76 x 191mm	1kg	£25.00
14011	1ltr bottle with flex tube	n/a	89 x 232mm	1kg	£27.00

# HAZARDOUS MATERIAL & FIRE RATED PRODUCTS DIP & FLOOR STANDING RINSE TANKS FOR FLAMMABLE LIQUIDS

Some contaminated components require soaking/washing in order to clean them and this can involve the use of large amounts of flammable liquids, which can pose a risk of fire and/or personnel injury.

For advice on these products please contact us on [01506 430309](tel:01506430309)/[advice@empteezy.co.uk](mailto:advice@empteezy.co.uk)



Quality  
Backed by our  
**10 Year**  
Limited Warranty



## DIP TANKS

- The simple solution to soaking "parts". These tanks are fitted with spring loaded stay-open lids with a fusible link which in the event of a fire, melts at 74°C and slams the lid shut, extinguishing the burning contents.

## RINSE TANKS

- Features a self-close cover that is a foot treadle operated to allow both hands to be free.

## ADDITIONAL INFORMATION

- Both types of tank are Factory Mutual approved and tested.



27615

### DIP TANKS

All our prices include delivery to a mainland UK address

MODEL	DESCRIPTION	OUTER Ø & HEIGHT	TARE WEIGHT	DELIVERED PRICE	WITH BASKET	DELIVERED PRICE
27601Z	4ltr steel tank	238 x 140mm	2kg	£85.00	n/a	n/a
27602Z	8ltr steel tank	238 x 254mm	3kg	£88.00	27901	£147.00
27605	19ltr steel tank	349 x 330mm	5kg	£112.00	27903	£191.00
27615	19ltr steel tank with HDPE liner	349 x 330mm	5kg	£320.00	27923	£488.00
27608	30ltr steel tank	397 x 362mm	6kg	£130.00	27906	£212.00

### FLOOR STANDING RINSE TANK

All our prices include delivery to a mainland UK address

MODEL	DESCRIPTION	SIZE WxDxH	TARE WEIGHT	DELIVERED PRICE
27220	83ltr tank	895 x 406 x 305mm	35kg	£733.00
27005	Parts basket for use with 27220	711 x 330 x 102mm		£10.00
27006	Sediment screen for use with 27220	584 x 349 x 19mm		£82.00

# HAZARDOUS MATERIAL & FIRE RATED PRODUCTS DRUM COVERS & DRUM LOCKS FOR 205LTR DRUMS

Convert open top 205ltr steel drums into fire safe bins and control access to expensive liquids.

To order please contact us on **01506 430309**/[www.empteezy.co.uk](http://www.empteezy.co.uk)

## DRUM COVERS

- You only need a spanner and a screwdriver to convert a standard 205ltr steel drum into a fire safe bin. The cover is constructed from steel with a highly chemical resistant powder coat paint finish which is tough and durable. The replaceable fusible-link assembly melts at 74°C to automatically slam the lid shut in the event of a fire in the drum, extinguishing the flames.



- The VaporTrap™ cover also converts a standard 205ltr steel drum but has a gasket to seal in vapour. There is a 121mm spring loaded, self closing port on the top of the lid so you don't have to open the full lid each time for maximum vapour retention. The manual latching cover vents to relieve pressure build-up and it also accepts a padlock (not supplied) for added security.

- Note: Drum not included.

## DRUM LOCKS

- A simple but extremely effective way to secure and control access to expensive liquids. The lock is made from corrosion resistant, non-sparking die cast zinc. To secure the drum lock it is not necessary to remove the original bung, therefore there is no contact with the drum contents. This elimination of potential content contamination has applications across many industries, including chemical and food processing



- Installs in seconds, simply place both halves around the bung lip, slide the lock bar through the halves and then attach a padlock (not supplied) through the end hole of the bar

- The steel set includes two units, one to fit over the 2" NPT plug and the other to fit over the 3/4" NPT plug

- The plastic set includes two units which fit over both 2" plugs

- 7.14mmØ shackle, typical of a No. 3 Master Lock.



## DRUM COVERS

MODEL	DESCRIPTION
26750Z	Self close with fusible link for use with 205ltr steel drums
26754	VaporTrap™ lid for use with 205ltr steel drums

All our prices include delivery to a mainland UK address

TARE WEIGHT	DELIVERED PRICE
7kg	£190.00
7kg	£555.00

## DRUM LOCKS

MODEL	DESCRIPTION
08508	Steel drum set - 2 locks, one for 2" & one for 3/4" bungs
08509	Plastic drum set - 2 locks

All our prices include delivery to a mainland UK address

TARE WEIGHT	DELIVERED PRICE
0.3kg	£72.00
0.7kg	£80.00

# HAZARDOUS MATERIAL & FIRE RATED PRODUCTS WASTE CONTAINERS FOR FLAMMABLE MATERIAL

Combustible material such as used wipes, solvent soaked cleaning cloths etc. can be a major fire hazard if left in unprotected containers.

For advice on oily waste cans please contact us on [01506 430309](tel:01506430309)/[advice@empteezy.co.uk](mailto:advice@empteezy.co.uk)



## OILY WASTE CANS

- The name is misleading, these containers are for use with any combustible waste material
- The self-closing lids reduce oxygen and stop a fire within the container, while the raised and ventilated base allows air to pass underneath dissipating heat and reducing the risk of spontaneous combustion.

## ADDITIONAL INFORMATION

- Both types of cans are Factory Mutual approved and tested.



### OILY WASTE CANS – RED

All our prices include delivery to a mainland UK address

MODEL	DESCRIPTION	OUTER Ø & HEIGHT	TARE WEIGHT	DELIVERED PRICE
*09200	8ltr counter top can	244 x 232mm	3kg	£70.00
09100	20ltr foot operated can	302 x 403mm	4.3kg	£83.00
09300	34ltr foot operated can	354 x 464mm	6kg	£95.00
09500	52ltr foot operated can	408 x 514mm	7kg	£121.00
09700	80ltr foot operated can	467 x 595mm	10kg	£175.00

\*09200 not TUV approved

# HAZARDOUS MATERIAL & FIRE RATED PRODUCTS

## SAFETY FUNNELS FOR FLAMMABLE LIQUIDS

These funnels have superior safety features that make them ideal for use with flammable liquids, such as solvents, thinners, oil and paint waste.

To order please contact us on **01506 430309**/[www.empteezy.co.uk](http://www.empteezy.co.uk)



Hinged lid prevents the spread of vapours

Fusible link melts at 74°C & cover snaps shut to extinguish flames

Tough, 1mm galvanised steel withstands use without distortion

Wide 273mm opening reduces spills while pouring

9.8ltr capacity allows for fast transfer of liquid

Fits standard 2" bungs on steel 205ltr drums

Lid latch accepts a padlock (not provided) to control access



08205



08207Z



Epoxy powder-paint finish provides excellent chemical resistance. Factory Mutual approved.

### DRUM SAFETY FUNNELS FOR USE WITH FLAMMABLES

All our prices include delivery to a mainland UK address

MODEL	STEEL LID TYPE	FUNNEL ØxH	DELIVERED PRICE
08207Z	Self close lid with 152mm flame arrester	273 x 254mm	£295.00
08205	Self close lid with 813mm flame arrester	273 x 254mm	£365.00



# HAZARDOUS MATERIAL & FIRE RATED PRODUCTS

## SAFETY DRUM TAPS

### FOR FREE FLOWING & VISCOUS LIQUIDS

To aid you in getting liquid from its main container into a smaller one for daily use, these taps have safety as the prime feature.

For advice on these products please contact us on [01506 430309](tel:01506430309)/[advice@empteezy.co.uk](mailto:advice@empteezy.co.uk)

#### TAPS

- These safety taps incorporate an internal flame arrester which prevents flashback of fire into the drum. Brass construction with a (PTFE) polytetrafluoroethylene seal assures a leak proof operation. The adjustable versions screw tightly into the drum and can then be adjusted to the dispensing position required with the spout downwards without damaging the thread or leakage. For trouble free dispensing of viscous non-corrosive flammables such as adhesives, paint or heavy oils above 30w, use the viscous gate valve model 08552.

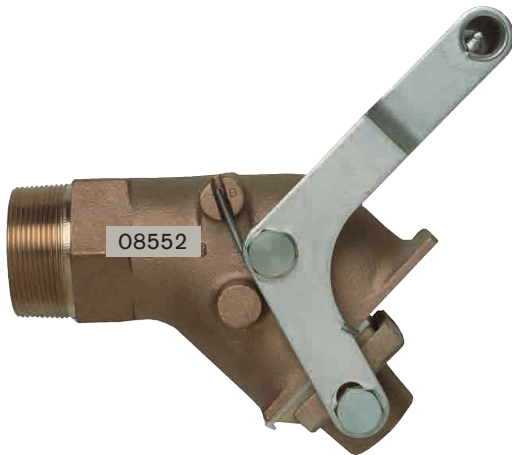
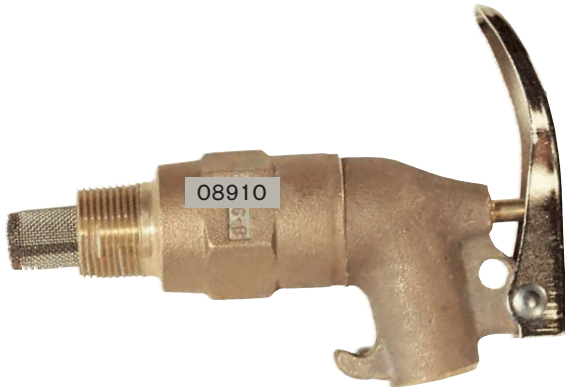

#### SAFETY DRUM TAPS

All our prices include delivery to a mainland UK address

MODEL	DESCRIPTION	THREAD	TARE WEIGHT	DELIVERED PRICE
08902	Brass rigid	19mm	1kg	£63.00
08910	Brass adjustable	19mm	1kg	£84.00
08540	Brass control flow - laboratory	19mm	0.5kg	£60.00
08552	Brass gate valve - viscous liquids	51mm	3kg	£208.00
08916	Stainless steel adjustable	19mm	1kg	£265.00

# HAZARDOUS MATERIAL & FIRE RATED PRODUCTS DRUM VENTS & ANTI STATIC WIRES TO REDUCE THE RISK OF EXPLOSION OR FIRE

Pressure build-up and static discharge can pose a serious hazard to staff or emergency service personnel, these products are designed to STOP this from happening.

To order please contact us on **01506 430309**/[www.empteezy.co.uk](http://www.empteezy.co.uk)



## SAFETY DRUM VENTS

- These Factory Mutual approved vents have an operating valve that opens at 0.35 bar internal pressure in normal service for automatic pressure relief
- Vacuum relief is either manual or automatic dependent on the model and permits 15ltr or more per minute to flow through a standard 19mm tap. All the vents have a flame arrester for added safety as standard.



08101



08300



08006

## ANTI STATIC WIRES

- Reduce the risk of fire from static electricity generated by the movement and flow of flammable liquids. By bonding between containers during liquid transfer and connecting drums to an earth you will greatly reduce the risk of a fire..



08497



08499



### SAFETY DRUM VENTS

All our prices include delivery to a mainland UK address

MODEL	DESCRIPTION	VACUUM RELIEF	THREAD	TARE WEIGHT	DELIVERED PRICE
08101*	Brass vertical vent for petroleum based product	Automatic	51mm	0.9kg	£124.00
08300	Brass horizontal vent for petroleum based product	Manual	51mm	0.5kg	£81.00
08005*	Non metallic vertical vent, plated steel flame arrester for petroleum based product	Automatic	51mm	0.5kg	£55.00
08006*	Non metallic vertical vent, stainless steel flame arrester for chlorinated solvents	Automatic	51mm	0.5kg	£103.00

\*These models must be installed in a vertical position

### ANTI STATIC WIRES

All our prices include delivery to a mainland UK address

MODEL	DESCRIPTION	END CONNECTIONS	TARE WEIGHT	DELIVERED PRICE
08497	Insulated 3m coiled	Hand clamp x 6mm terminal	1kg	£50.00
08499	Flexible 1m	Dual hand clamps	1kg	£117.00



# EMERGENCY SHOWERS



# BEST BUYS

---

For areas where a plumbed water supply is not available **SE-4320** is the safe and practical solution, delivering 76ltr of water via the eye wash system or the shower attachment. £309.00 – SEE PAGE 126



For complete cover you should consider the **SE-603** which gives you a full shower system and eye/face wash option. £994.00 – SEE PAGE 126



A simple but effective face wash basin **SE-580** is a wall mounted plastic basin with 2 spray heads. £223.00 – SEE PAGE 128



**SE-920** - a simple hand held hose that delivers aerated water by simply squeezing the trigger. £185.00 – SEE PAGE 129



# EMERGENCY SHOWERS EYE & FACE WASH SYSTEMS SHOWERS & PORTABLE SYSTEMS

The Health and Safety (First-Aid) Regulations 1981 and the Control of Substances Hazardous to Health (COSHH) Regulations 1996 require that Emergency Safety Showers and/or Eye/Face wash systems are provided wherever employees may be exposed to chemical/burn injuries.

For advice please contact us on [01506 430309](tel:01506430309)/[advice@empteezy.co.uk](mailto:advice@empteezy.co.uk)



## FREE STANDING SHOWER AND EYE/FACE WASH

- SE-603 is fitted with the Speakman® impeller action showerhead which causes the water stream to swirl and provides soft full coverage on the person using it. The shower is activated by pulling on the large yellow handle
- The eye/face wash produces a 230mm x 200mm flow of aerated (soft bubbles that follow the contours of the face) water from 6 outlets (3 in each side).

## PORTABLE EYE/FACE WASH SYSTEMS

- SE-4320 is a 76ltr capacity gravity operated eyewash with side fitted drench hose
- Comes complete with a bracket to allow wall mounting
- Ideal for areas without plumbed water just fill with tap water and add SE-4210 water preservative to treat for 180 days
- SE-590 is a 38ltr stainless steel vessel complete with pressure gauge, relief valve and an air connector for charging
- Water is delivered from either the twin spray heads for the eyes and face or the drench hose attachment
- Flow rate is nearly constant as the unit empties.

## ADDITIONAL INFORMATION

- All models meet the American National Standard ANSI Z 358.1 which is an internationally recognised standard covering the design parameters for Emergency Safety Showers and Eye/Face Wash Fountains
- Full specifications for all models are available upon request.

### SHOWER & PORTABLE SYSTEMS

All our prices include delivery to a mainland UK address

MODEL	DESCRIPTION	DELIVERED PRICE
SE-603	Free standing shower with eye/face wash bowl (Safety T-Zone)	£994.00
SE-4320	Free standing or wall mounted gravity eyewash with drench hose	£309.00
SE-4210	Water preservative case of 4 x 8oz bottles for use with SE-4320	£54.00
SE-590	Stainless steel portable eye wash	£1096.00

# EMERGENCY SHOWERS EYE & FACE WASH SYSTEMS WALL MOUNTED SHOWERS

In the event that someone is contaminated with chemicals or other hazardous liquids, removing that liquid quickly, gently and thoroughly becomes a priority.

To order please contact us on **01506 430309**/[www.empteezy.co.uk](http://www.empteezy.co.uk)

## WALL MOUNTED SHOWERS

- Both the showers shown on this page are merely examples from a comprehensive range we have available
- SE-227 has a plastic 203mmø shower head
- SE-227-SS has a stainless steel 203mmø shower head
- Both are activated via a 90° stay open valve by pulling on the large triangular handle.

## ADDITIONAL INFORMATION

- The last thing someone who is already in shock and may be feeling the effect of the liquid spilled on him/her wants are painful jets of water hitting them. The impeller action that these showers have turns the water into a swirling motion which means that the flow of the water is softer when it hits the body, it also provides complete body cover for efficient decontamination
- The full specifications for all models are available upon request.

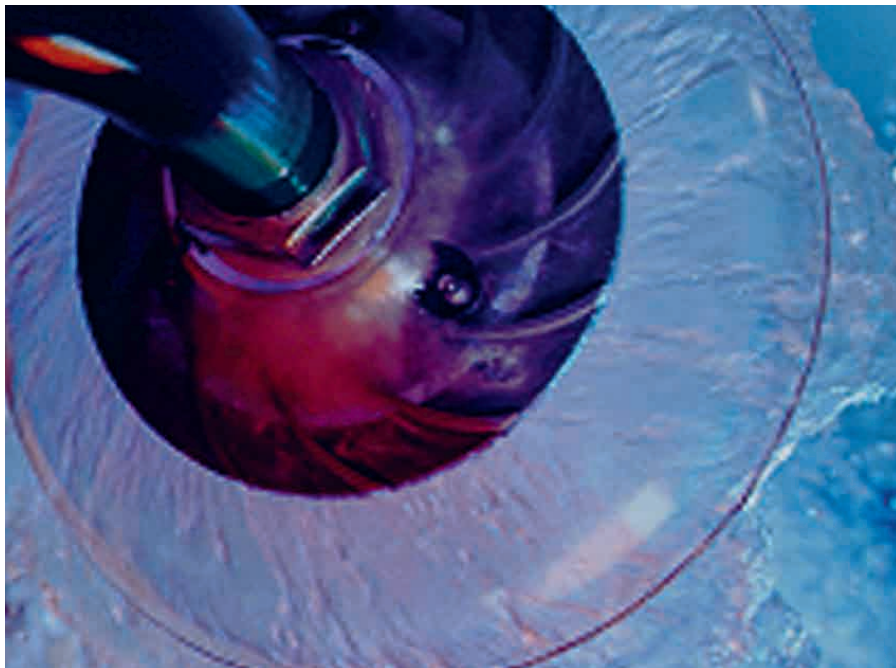

## WALL MOUNTED SHOWERS

All our prices include delivery to a mainland UK address

MODEL	DESCRIPTION	DELIVERED PRICE
SE-227	Wall Deluge shower galvanised steel with plastic shower head	£198.00
SE-227-SS	Wall Deluge shower all stainless steel	£668.00

# EMERGENCY SHOWERS EYE & FACE WASH SYSTEMS EYE WASH & EYE/FACE WASH BASINS

Having one of these units located in the right place can mean the difference between someone suffering permanent damage or a treatable injury.

For advice please contact us on **01506 430309/advice@empteezy.co.uk**



EYE/FACE WASH



SE-400



SE-401



SE-505



SE-580-AER

## EYE/FACE WASH BOWLS

- Both these models are fitted with aerated water outlets (see below for explanation)
- SE-400 has a stainless steel wall mounted bowl fitted with 6 aerated outlets (3 in each side) which produce a 230mm x 200mm carpet of gentle water
- SE-401 is to the same specification as SE-400 but uses a plastic bowl.

## EYE WASH BOWLS

- SE-580-AER is a wall mounted eye wash system with a plastic bowl and aerated water outlets
- SE-505 has aerated water with a wall mounted stainless steel bowl.

## ADDITIONAL INFORMATION

- Aerated water clings to eyes and skin, while ordinary sprayed water tends to bounce off. Aeration is especially important as the human face is full of contours around the eyes, face and nose
- Aerated water reduces the risk of harmful contaminants being forced into cuts or soft mucous membranes
- Full technical specifications are available upon request.

## EYE WASH & EYE/FACE WASH BASINS

All our prices include delivery to a mainland UK address

MODEL	DESCRIPTION	DELIVERED PRICE
SE-400	Stainless steel wall mounted eye/face wash bowl	£549.00
SE-401	Plastic wall mounted eye/face wash bowl	£474.00
SE-505	Stainless steel wall mounted eye wash bowl	£436.00
SE-580	Plastic wall mounted eye wash bowl	£223.00
SE-580-AER	Plastic wall mounted eye wash bowl - aerated	£248.00

# EMERGENCY SHOWERS EYE & FACE WASH SYSTEMS LABORATORY HANDHELD EYE WASH/DRENCH HOSES

Laboratories are by their very nature full of various liquids posing an array of risks to staff if they spill/splash on to them.

To order please contact us on **01506 430309**/[www.empteezy.co.uk](http://www.empteezy.co.uk)

## LABORATORY HANDHELD EYE WASH & DRENCH HOSES

- SE-920 is a simple hand held hose that delivers aerated water from a single outlet which is activated by a simple squeeze handle, it also has an integral hanger for storing it
- SE-921 and SE-927 are designed for mounting onto benches up to 164mm thick. The "pull out" flexible hoses make them practical and easy to use. Both models provide aerated water outlets.



SE-920

## ADDITIONAL INFORMATION

- Where the eyes, face and/or body of a person may be exposed to chemicals or fine particles or dust, it is recommended that you should make provision for facilities to aid rapid flushing and/or drenching to minimise the risk of permanent injury
- Before you site any equipment you should consider the following; make sure there is easy unhindered access at all times, consider the environment, ambient temperature and of course water pressure and once you have installed the equipment mark it on your site plan, make all staff aware of where it is and how to use it. Provide highly visible signage and ensure all equipment is regularly operated, checked and maintained
- Quotations containing a full specification are available upon request.



SE-921



SE-927

## LABORATORY HANDHELD EYE WASH/DRENCH HOSES

All our prices include delivery to a mainland UK address

MODEL	DESCRIPTION	DELIVERED PRICE
SE-920*	Hand held single outlet	£185.00
SE-921	Bench mounted single outlet	£224.00
SE-927	Bench mounted twin outlet	£312.00

\*Additional wall mounted bracket (model WMB) available, contact us for details.





# DOUBLE SKINNED TANKS



# BEST BUYS

---

Waste oil is an expensive commodity and if you can store it in bulk your disposal costs normally come down. You must of course ensure that the tank is fully compliant with Oil Storage regulations. Our WO1340 is compliant and holds 1340ltr fully protected in a double skinned tank for only £774.00 (remember our prices include delivery to a mainland UK address) – SEE PAGE 133



Secure, fully bunded fuel dispensing from only £1343.00 including delivery to a mainland UK address, EMP1300DD – SEE PAGE 134



# FULLY CONTAINED TANKS

For regulation advice contact us or visit [www.netregs.gov.uk](http://www.netregs.gov.uk)/[www.sepa.org.uk](http://www.sepa.org.uk)

## STORING OIL

- Oil is among the most common pollutants in the UK and cleaning up oil spills can be difficult and expensive. Dealing with a spill will cause you a great deal of inconvenience and expense so make sure you have insurance cover, not just to replace the lost oil but to include:
  - Environmental clean-up for accidental oil loss
  - A high enough liability limit to cover you if neighbouring land and/or boreholes are affected
  - The costs of cleaning up oil on your own property.
- In England and Wales, it is against the law to cause water pollution and there are specific regulations that may apply to your oil storage tank. Non compliance with these regulations is an offence and may result in enforcement action being taken against you. For detailed information go to [www.netregs.gov.uk](http://www.netregs.gov.uk) or [www.sepa.org.uk](http://www.sepa.org.uk)

## BEFORE YOU BUY

- You should think about environmental and fire protection, access, maintenance and security requirements before deciding where to put a new or replacement oil storage tank
- Avoid high risk areas such as:
  - Within 50 metres of a spring, well or borehole
  - Within 10 metres of a watercourse
  - Places where spilt oil could enter open drains, loose fitting manhole covers or soak into the ground where it could pollute groundwater
  - Places where a spill could run over hard ground to enter a watercourse or soak into the ground where it could pollute groundwater
  - Places where tank vent pipe outlets can't be seen from the filling point
  - Above roof level as spilt oil can run down guttering which is connected to surface water systems.

## ACCESS

- You should consider access for maintenance and deliveries to the tank (filling). Check with your delivery company before making the final decision on where to place a tank. You need to take into account pollution prevention and health and safety aspects of filling the tank, this includes where the tanker can safely park to make the delivery, where the delivery pipes will run and access to the tank.

## REMINDERS

- Before choosing a new or replacement tank, you should check the following:
  - What if any, legal requirements you must comply with
  - Suitability of the tank to your requirements
  - Do you need to install any secondary containment
  - Do you need to install crash barrier protection
  - The location of the tank
  - If you're replacing a tank, what will you do with the old one
- Choose a tank that:
  - Is expected to last at least 20 years, with proper maintenance, before it needs to be replaced
  - Is made of a material that is suitable for the type of oil stored
  - Is of sufficient strength and structural integrity to ensure that it won't burst or leak in ordinary use



# FULLY CONTAINED TANKS DOUBLE SKINNED WASTE OIL TANKS

Rather than have drums and other containers of waste oil sitting around, these tanks allow you to collect all your waste oil in one place prior to collection.

For advice on tanks please contact us on [01506 430309](tel:01506430309)/[advice@emptezy.co.uk](mailto:advice@emptezy.co.uk)

## WASTE OIL TANKS

- These products are effectively tanks within tanks with the space between them acting as the secondary containment area to catch spills in the event of an incident
- The space between the two tanks will hold 110% of the inner tanks capacity
- Manufactured from tough polyethylene with a large diameter opening to help reduce the risk of spills during filling
- All tanks are suitable for use with Diesel, Kerosene and some other Oils, please contact us to discuss your requirements
- It is recommended that you don't site your tank on "traffic routes" and that you further protect it with a "crash barrier" system.



OTHER SIZES AVAILABLE ON REQUEST

## WASTE OIL TANKS

All our prices include delivery to a mainland UK address

MODEL	CAPACITY	DIAMETER	LENGTH	WIDTH	HEIGHT	DELIVERED PRICE
WO650	650ltr	n/a	1260mm	630mm	1350mm	£920.00
WO1340	1340ltr	1410mm	n/a	n/a	1500mm	£774.00
WO2500	2500ltr	n/a	2640mm	1450mm	1620mm	£1241.00
WO5000	5000ltr	2120mm	n/a	n/a	2300mm	£1895.00

# FULLY CONTAINED TANKS DOUBLE SKINNED DIESEL DISPENSING TANKS

Have your own fuel depot on site and eliminate the need to have fuel cans lying around, with these systems you control access, monitor use and greatly reduce the risk of a spill.

To order please contact us on **01506 430309**/[www.empteezy.co.uk](http://www.empteezy.co.uk)

## DIESEL DISPENSING TANKS

- Fully contained the space between the inner and outer tank will hold 110% of the inner tanks capacity
- Designed for use with Diesel and Kerosene, but please feel free to check with use prior to purchase
- All models are fitted with overfill prevention devices as standard.

### EMP5000DD

- Fitted with a bund alarm to indicate that a spill into the bund has occurred
- The dispensing system is fitted with a 3 digit flow meter for a "fill by fill" count and a 6 digit readout provides a running total
- Fitted with a non-return valve
- Pump rate 55ltr per min.
- It is recommended that you don't site your tank on "traffic routes" and that you further protect it with a "crash barrier" system.



### EMP1300DD & EMP2350DD

- The filling point has a 2" connection housed behind the hinged inspection hatch
- Both models are fitted with an automatic nozzle complete with flow meter
- Pump rate 55ltr per min.



OTHER SIZES AVAILABLE ON REQUEST

### DIESEL DISPENSER TANKS

All our prices include delivery to a mainland UK address

MODEL	CAPACITY	DIAMETER Ø	HEIGHT	DELIVERED PRICE
EMP1300DD	1300ltr	1410mm	1740mm	£1343.00
EMP2350DD	2350ltr	1700mm	1850mm	£1529.00
EMP5000DD	5000ltr	2120mm	2300mm	£3174.00

# FULLY CONTAINED TANKS DOUBLE SKINNED LIQUID STORAGE TANKS

These tanks allow you to plum them in for applications such as the supply of fuel for a heating system.

For advice on tanks please contact us on **01506 430309/advice@emptezy.co.uk**



STH2500B

## LIQUID STORAGE TANKS

- It is recommended that these tanks are located within a secondary bunded area and that the connecting pipe runs up and over the bund wall not through it
- All units are fitted with a 2" fill point located behind a 4" hinged inspection hatch which is further covered by an 18" cover. They are also fitted with a fill gauge to indicate the level in the main tank.



STR1000B



STH1235B

OTHER SIZES AVAILABLE ON REQUEST

### LIQUID STORAGE TANKS

All our prices include delivery to a mainland UK address

MODEL	CAPACITY	LENGTH	WIDTH	HEIGHT	DELIVERED PRICE
STR1000B	1000ltr	1890mm	640mm	1350mm	£941.00
STH1235B	1235ltr	1970mm	1280mm	1260mm	£1029.00
STH2500B	2500ltr	2640mm	1450mm	1620mm	£1310.00



# WASTE HANDLING



# BEST BUYS



For “wet” loads such as metal turnings from a CNC machine you won’t find better than an **Auto Tipping Skip**, with a fully welded bucket, dampened tipping action and fully automatic unlock, tip and relock system. Prices start from as little as £716.00 – SEE PAGE 139

Volume loads such as paper off cuts, general waste or metal waste from stamping machines are easily collected, moved and dumped with our **Auto Dumping Containers**. Prices start from £802.00 – SEE PAGES 140 and 141



Heavy duty waste needs a heavy duty solution, our **Roll Forward Skips** are ideal for items such as rubble from building sites or foundry related waste. Prices from £874.00 including delivery to a mainland UK address – SEE PAGE 142



Due to the volatile nature of both fuel and steel prices Empteezy reserves the right to amend the prices shown in this catalogue without notice. Note: All prices shown include delivery to a mainland UK address.





# WASTE HANDLING ATTACHMENTS FOR FORK LIFT TRUCKS & SKIP CANOPIES

Move waste from the production area to the waste skip safely.

For advice on waste handling please contact us on [01506 430309](tel:01506430309)/[advice@empteezy.co.uk](mailto:advice@empteezy.co.uk)

## WASTE HANDLING EQUIPMENT

APPLICATIONS	CAPACITIES	MODEL
<p>Typical use would be the collection of waste at "work stations" i.e. metal turnings from a CNC machine or wood off cuts from a saw mill, even general waste created during a working day.</p> <p>Because of their construction (fully welded "bucket") the ATS range is perfect for "wet" loads such as cutting fluid contaminated swarf from milling/CNC machines.</p>	<p><b>0.25m<sup>3</sup> to 1.6m<sup>3</sup></b> <b>500kg to 1500kg</b></p>	<p><b>Auto Tipping Skips (ATS)</b></p> 
<p>Because the base of these models "drops away" they are not suitable for wet loads or powders.</p> <p>They are however ideal for; general waste, paper off cuts from guillotines and metal waste from stamping machines etc.</p>	<p><b>0.5m<sup>3</sup> to 2.0m<sup>3</sup></b> <b>1000kg to 2000kg</b></p>	<p><b>Auto Dumping Containers (ADC)</b></p> 
<p>The "rolling" disposal action of the RFS range makes it highly suitable for heavy duty loads like concrete and brick rubble found on building sites.</p>	<p><b>0.5m<sup>3</sup> to 1.5m<sup>3</sup></b> <b>1250kg to 1750kg</b></p>	<p><b>Roll Forward Skips (RFS)</b></p> 

## WASTE HANDLING EQUIPMENT

- The original and safest to use waste handling skips available in the market:
  - No wires
  - No pulleys
  - No climbing
 Everything operates from the safety of the Fork Lift Truck's cab.

**EASY TO OPERATE: DEMONSTRATIONS AVAILABLE VIA VIDEO ON OUR WEBSITE AT [www.empteezy.co.uk](http://www.empteezy.co.uk)**

## SKIP CANOPIES

APPLICATIONS	CAPACITIES	MODEL
<p>Stop waste from being blown around.</p> <p>Stop rainwater accessing the skip.</p> <p>Stop acts of vandalism</p> <p>Stop unwanted dumping and cross contamination.</p>	<p><b>10m<sup>3</sup> to 12m<sup>3</sup> skips</b> <b>Bespoke sizes and styles available on request</b></p>	<p><b>Skip Canopies</b></p> 

- Skip Canopies give you control over access to your waste and help stop skips from filling with rainwater, why pay to dispose of it or have it "wash" oily residues out of the skip and cause pollution.

# WASTE HANDLING AUTO TIPPING SKIPS FOR USE WITH FORK LIFT TRUCKS

The safe and practical way to collect and dispose of waste in the work place.

To order please contact us on **01506 430309**/[www.empteezy.co.uk](http://www.empteezy.co.uk)

## ATS

- Fully seam welded bucket
- 3mm steel plate construction
- Fitted with a damper to control the tipping action
- CE marked
- Unit can be galvanised as an option to reduce corrosion
- 5 standard versions
- Available on legs or castors
- Lids available.



## SAFETY

- Completely automatic operation
- No wires, pulleys or handles it's all automatic
- No climbing Fork Lift Truck masts to empty
- All operated from the safety of the cab
- Retaining chains fitted as standard
- Floor tipping handle can be fitted as an option.

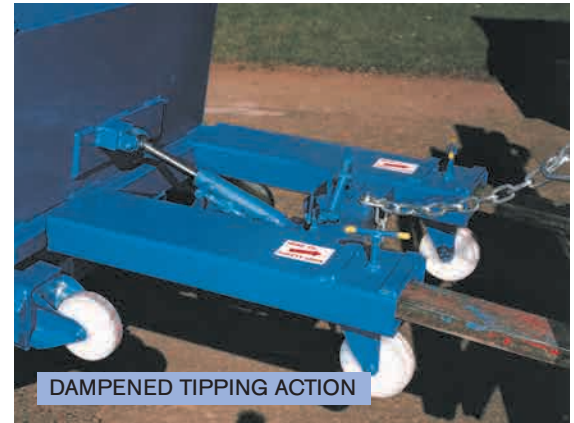

## OPTIONS

- We can supply a durable cover secured by welded hooks to your unit to help stop debris being blown out or reduce rainwater build up if storing the unit outside. Easy to remove and replace, they are a cost effective answer to heavy metal lids.



## AUTO TIPPING SKIPS

All our prices include delivery to a mainland UK address

MODEL	LENGTH	WIDTH	HEIGHT	NOM VOL	MAX LOAD	DELIVERED PRICE
ATS2L (with legs)	1275mm	818mm	525mm	0.25m <sup>3</sup>	500kg	£716.00
ATS2C (as above with castors)	1275mm	818mm	568mm	0.25m <sup>3</sup>	500kg	£846.00
ATS5L (with legs)	1450mm	820mm	862mm	0.5m <sup>3</sup>	1000kg	£866.00
ATS5C (as above with castors)	1450mm	820mm	905mm	0.5m <sup>3</sup>	1000kg	£1014.00
ATS7L (with legs)	1530mm	990mm	856mm	0.7m <sup>3</sup>	1000kg	£947.00
ATS7C (as above with castors)	1530mm	990mm	958mm	0.7m <sup>3</sup>	1000kg	£1095.00
ATS11L (with legs)	1760mm	1290mm	856mm	1.1m <sup>3</sup>	1250kg	£1071.00
ATS11C (as above with castors)	1760mm	1290mm	958mm	1.1m <sup>3</sup>	1250kg	£1221.00
ATS16L (with legs)	1790mm	1580mm	916mm	1.6m <sup>3</sup>	1500kg	£1334.00
ATS16C (as above with castors)	1790mm	1580mm	1018mm	1.6m <sup>3</sup>	1500kg	£1484.00

# WASTE HANDLING AUTO DUMPING SKIPS FOR USE WITH FORK LIFT TRUCKS

Operated from the safety of the cab of the fork lift truck.

For advice on waste handling please contact us on **01506 430309/advice@empteezy.co.uk**



## ADC

- Greatest volume from the lowest overall size
- Top mounted fork pockets and guides
- Drop away floor for quick dumping
- All steel construction
- CE Marked
- 6 standard versions
- Available on legs or castors.

## SAFETY

- Completely automatic operation
- No wires, pulleys or handles, it's all automatic
- No climbing Fork Lift Truck masts to empty
- All operated from the safety of the cab
- Retaining chains fitted as standard.



ADC5

ADC10

ADC20

- Fit in small or awkward areas
- Easy to manoeuvre: with hand pallet truck
- Available on castor or legs

- For maximum volume

- For long lengths and bulky items
- Fitted with 4 all swivel, heavy duty castors as standard

## AUTO DUMPING CONTAINERS

All our prices include delivery to a mainland UK address

MODEL	LENGTH	WIDTH	*HEIGHT	NOM VOL	MAX LOAD	DELIVERED PRICE
ADC5L (with legs)	1020mm	870mm	880mm	0.5m <sup>3</sup>	1000kg	£802.00
ADC5C (as above with castors)	1020mm	870mm	920mm	0.5m <sup>3</sup>	1000kg	£961.00
ADC7L (with legs)	1020mm	970mm	1040mm	0.7m <sup>3</sup>	1000kg	£864.00
ADC7C (as above with castors)	1020mm	970mm	1080mm	0.7m <sup>3</sup>	1000kg	£1023.00
ADC10L (with legs)	1320mm	1050mm	1040mm	1.0m <sup>3</sup>	1250kg	£929.00
ADC10C (as above with castors)	1320mm	1050mm	1080mm	1.0m <sup>3</sup>	1250kg	£1086.00
ADC15C (with castors)	1690mm	1050mm	1080mm	1.5m <sup>3</sup>	1500kg	£1221.00
ADC20C (with castors)	2000mm	1050mm	1080mm	2.0m <sup>3</sup>	1500kg	£1364.00

\*This measurement is from ground level to the top of the fork pocket.

# WASTE HANDLING AUTO DUMPING SKIPS FOR USE WITH FORK LIFT TRUCKS

The safe and practical way to collect and dispose of waste in the work place.

To order please contact us on **01506 430309**/[www.empteezy.co.uk](http://www.empteezy.co.uk)

## ADC25C

- Built to the same standard as the rest of the range but specifically developed for use with guillotines at a major automotive company
- Can of course be used for other applications that the overall size suits
- Only available on castors.



## OPTIONS FOR USE WITH FULL RANGE

- Crane lifting lugs
- Chute mouth (side guides for base)
- Lockable hinged lids (not available on ADC25C)
- We can supply a durable cover secured by welded hooks to your unit to help stop debris being blown or reduce rainwater build up if storing the unit outside. Easy to remove and replace, they are a cost effective answer to heavy metal lids.



## OPTIONS AVAILABLE



CRANE LIFT



CHUTE MOUTH - FLANKED BASE TO AVOID SIDE SPILLS



LOCKABLE LIDS - CAN BE FITTED TO ANY MODEL, EXCEPT ADC25C

## AUTO DUMPING CONTAINERS

MODEL	LENGTH	WIDTH	*HEIGHT	NOM VOL	MAX LOAD	DELIVERED PRICE
ADC25C	2650mm	870mm	700mm	1.25m <sup>3</sup>	2000kg	£1401.00

\*This measurement is from ground level to the top of the fork pocket.

All our prices include delivery to a mainland UK address

# WASTE HANDLING ROLL FORWARD SKIPS FOR USE WITH FORK LIFT TRUCKS

Robust construction makes these models ideal for heavy loads.

For advice on waste handling please contact us on **01506 430309/advice@empteezy.co.uk**



## RFS

- Fully seam welded bucket
- 4mm steel plate construction
- Rolling frame provides additional strength
- CE marked
- 4 standard versions
- Available on legs or castors.

## SAFETY

- Completely automatic operation
- No wires, pulleys or handles it's all automatic
- No climbing Fork Lift Truck masts to empty
- All operated from the safety of the cab
- Retaining chains fitted as standard
- Available on legs or castors.

## OPTIONS

- We can supply a durable cover secured by welded hooks to your unit to help stop debris being blown or reduce rainwater build up if storing the unit outside. Easy to remove and replace, they are a cost effective answer to heavy metal lids.



## AUTO ROLL FORWARD SKIPS

All our prices include delivery to a mainland UK address

MODEL	LENGTH	WIDTH	HEIGHT	VOLUME	DELIVERED PRICE
RFS5L (with legs)	1500mm	815mm	1050mm	0.5m <sup>3</sup>	£874.00
RFS5C (as above with castors)	1500mm	815mm	1152mm	0.5m <sup>3</sup>	£1023.00
RFS7L (with legs)	1500mm	1070mm	1050mm	0.7m <sup>3</sup>	£959.00
RFS7C (as above with castors)	1500mm	1070mm	1152mm	0.7m <sup>3</sup>	£1108.00
RFS11L (with legs)	1500mm	1316mm	1050mm	1.1m <sup>3</sup>	£1151.00
RFS11C (as above with castors)	1500mm	1316mm	1152mm	1.1m <sup>3</sup>	£1299.00
RFS15L (with legs)	1660mm	1570mm	1140mm	1.5m <sup>3</sup>	£1339.00
RFS15C (as above with castors)	1660mm	1570mm	1242mm	1.5m <sup>3</sup>	£1488.00

# WASTE HANDLING ROLL FORWARD SKIPS FOR USE WITH FORK LIFT TRUCKS

Safely operated from the cab of the fork lift truck.

To order please contact us on **01506 430309**/[www.empteezy.co.uk](http://www.empteezy.co.uk)

## RFS OPTIONS

- Liquid separation/drainage plate, ideal when working with coolant contaminated off cuts of metal
  - Drainage tap
  - Folding lids
  - Lockable lids (not RFS15)
- Note: If you have a specific application our sales team are available to discuss it with you

FOLDING LID

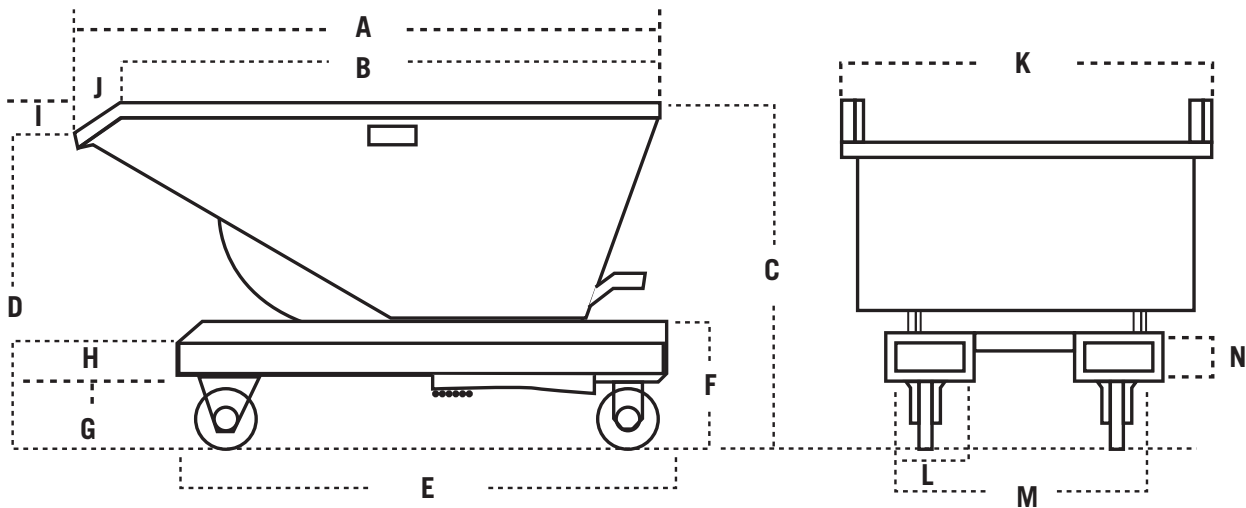

## DETAILED MEASUREMENTS

MODEL	A	B	C	D	E	F	G	H	I	J	K	L	M	N
RFS5	1500	1350	1152	1007	1250	377	188	100	145	150	815	165	800	80
RFS7	1500	1350	1152	1007	1250	377	188	100	145	150	1070	165	800	80
RFS11	1500	1350	1152	1007	1250	377	188	100	145	150	1316	165	800	80
RFS15	1660	1350	1242	1182	1500	377	188	100	60	-	1570	165	800	80

## AUTO ROLL FORWARD SKIPS WEIGHTS & LOAD CENTRE

MODEL	MAX LOAD	TARE WEIGHT	LOAD CENTRE OPEN	LOAD CENTRE CLOSED
RFS5	1250kg	225kg	750mm	900mm
RFS7	1250kg	250kg	750mm	900mm
RFS11	1750kg	300kg	750mm	900mm
RFS15	1750kg	450kg	830mm	1020mm

# WASTE HANDLING SKIP CANOPIES CONTROLLED ACCESS

Do you suffer from pollution from leaking skips or waste blowing out of them? If so, we have the solution.

For advice on waste handling please contact us on [01506 430309](tel:01506430309)/[advice@empteezy.co.uk](mailto:advice@empteezy.co.uk)



## SKIP CANOPIES

- Based on a solid H beam frame construction the canopy is created using Plastisol corrugated sheet cladding
- Options include: Fully seam welded sumps to contain any liquid leaking from the skip. Door systems to control access and fully contain loose, flyaway waste and configurations to accommodate different numbers and sizes of skips.

**Note:** As these units are built to your specific application we have to carry out a site assessment, this service carries no onus on you to purchase and is of course confidential and free of charge.

You will require a firm level concrete base to house the system on.

**PRICES AVAILABLE ON APPLICATION**

