

CIRCULAR VIBRATING SCREEN

Tecnical data sheet

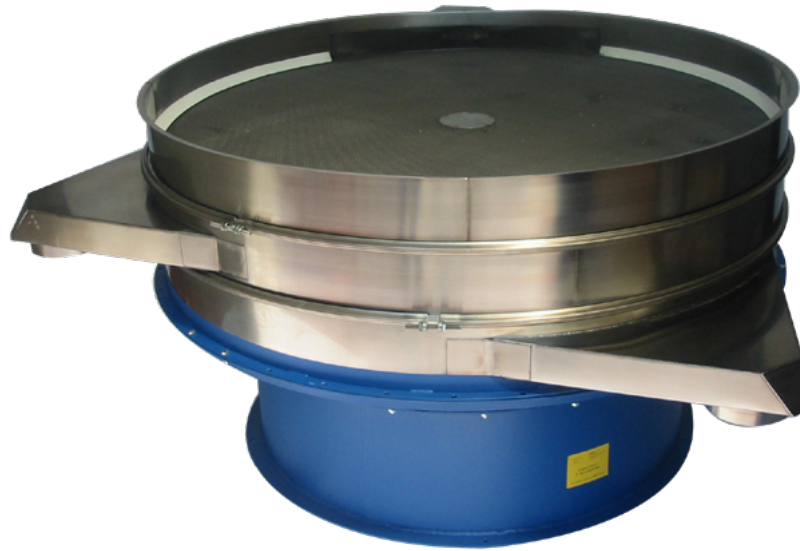

Description

Companies increasingly need to treat their products, to ensure perfect quality. With its circular vibrating screens, ERIMAKI allows to meet this need.

Thanks to the simple adjustment of counterweights on the motor axis and to the three-dimensional vibration they generate, our circular vibrating screens allow to sieve, classify, dedust and filter a very wide range of products, achieving good results even with fine products.

The vibrating motion of the screen runs both horizontally and vertically and can be adjusted in both directions. The distinguishing feature of the ERIMAKI vibrating screen is the possibility to easily and quickly alter the vibrating movement and, as a consequence, the behaviour of the material to be sieved. By installing an inverter, besides, you can also change the vibration speed. This provides great flexibility of use, with both solid and liquid products.

The ERIMAKI vibrating screens require no special installation structures, as the upper section transmits no vibration to the base, which as a consequence may even be equipped with wheels. Thanks to the simplicity of their design, besides, the vibrating screens can also be disassembled very quickly for cleaning or mesh replacement.

On each vibrating screen you can install 1 to 4 separation stages, thus getting from 2 to 5 product fractions. The screen may be made of carbon steel or stainless steel, and equipped with different optional accessories.

The ERIMAKI vibrating screens provide good results and are easy to use, at truly competitive costs. The wide range of models (from Ø 400 to Ø 2200 mm) can meet any type of requirement. Besides manufacturing and selling screens and circular vibrating screens, sieves and electrical sieving machines, rotary separators and static separators, tumbler screens and direct discharge screens, our company also offers a sieving trial at our in-house laboratory. As an alternative it provides prospective customers with trial equipment, directly at their premises.

CIRCULAR VIBRATING SCREEN

Tecnical data sheet



Operation

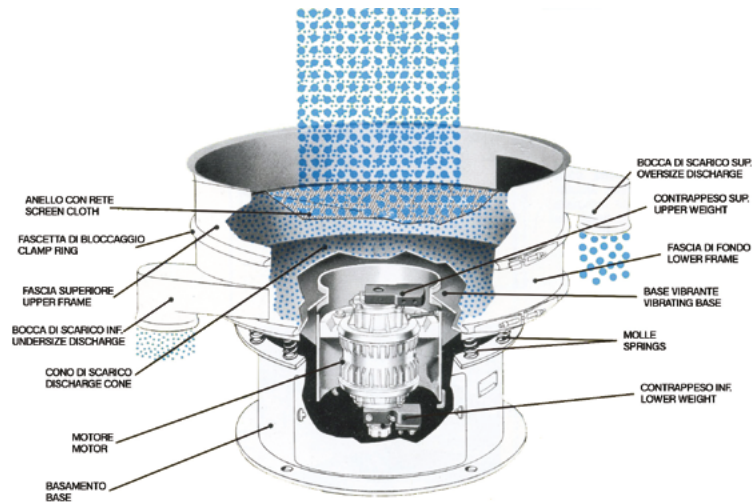

Product distribution on the mesh

- Straight-line distribution
- Normal spiral distribution
- Various spiral distribution
- Centripetal spiral distribution

Fields of application

- Solid and liquid materials

Accessories

- Self-cleaning ball system
- Self-cleaning kleener system
- Self-cleaning brush system
- Cover
- Meshes

CIRCULAR VIBRATING SCREEN

Tecnical data sheet



Dimensions

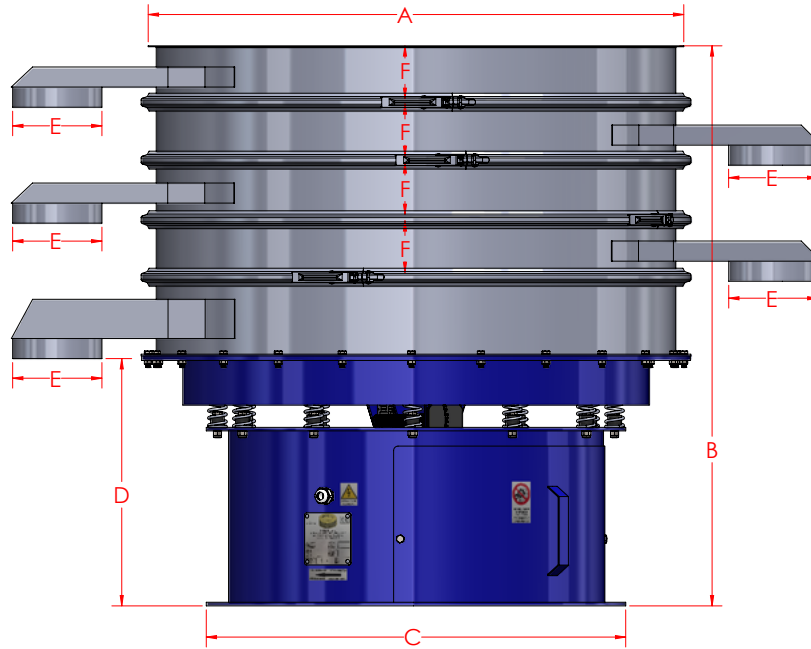

Diameter 400

Meshes	A	B	C	D	E	F
N. 1	Ø 445	H 700	Ø 470	H 420	Ø 80	H 100
N. 2	Ø 445	H 820	Ø 470	H 420	Ø 80	H 100
N. 3	Ø 445	H 940	Ø 470	H 420	Ø 80	H 100

Diameter 600

Meshes	A	B	C	D	E	F
No. 1	Ø 600	H 890	Ø 510	H 560	Ø 150	H 160
No. 2	Ø 600	H 1010	Ø 510	H 560	Ø 150	H 160
No. 3	Ø 600	H 1130	Ø 510	H 560	Ø 150	H 160
No. 4	Ø 600	H 1300	Ø 510	H 560	Ø 150	H 120

Diameter 760

Meshes	A	B	C	D	E	F
No. 1	Ø 760	H 890	Ø 616	H 560	Ø 150	H 160
No. 2	Ø 760	H 1010	Ø 616	H 560	Ø 150	H 160
No. 3	Ø 760	H 1130	Ø 616	H 560	Ø 150	H 160
No. 4	Ø 760	H 1300	Ø 616	H 560	Ø 150	H 120

ERIMAKI SNC di Cecilia Janni & C. - Via Timavo 36, 20037 Paderno Dugnano (Milan) - Italy

Phone +39 02.99044723 - +39 02.99044734 | Fax +039 02.99044729 | info@erimaki.it | www.erimaki.it

C.C.I.A.A 1169255 Codice Fiscale 07604340153 Partita IVA 02537230969

CIRCULAR VIBRATING SCREEN

Tecnical data sheet



Diameter 900

Meshes	A	B	C	D	E	F
No. 1	Ø 900	H 890	Ø 810	H 560	Ø 150	H 160
No. 2	Ø 900	H 1010	Ø 810	H 560	Ø 150	H 160
No. 3	Ø 900	H 1130	Ø 810	H 560	Ø 150	H 160
No. 4	Ø 900	H 1300	Ø 810	H 560	Ø 150	H 120

Diameter 1200

Meshes	A	B	C	D	E	F
No. 1	Ø 1200	H 890	Ø 940	H 560	Ø 200	H 160
No. 2	Ø 1200	H 1010	Ø 940	H 560	Ø 200	H 160
No. 3	Ø 1200	H 1130	Ø 940	H 560	Ø 200	H 160
No. 4	Ø 1200	H 1300	Ø 940	H 560	Ø 200	H 120

Diameter 1500

Meshes	A	B	C	D	E	F
N. 1	Ø 1480	H 890	Ø 1085	H 560	Ø 200	H 160
N. 2	Ø 1480	H 1010	Ø 1085	H 560	Ø 200	H 160
N. 3	Ø 1480	H 1130	Ø 1085	H 560	Ø 200	H 160
N. 4	Ø 1480	H 1300	Ø 1085	H 560	Ø 200	H 120

Diameter 1800

Meshes	A	B	C	D	E	F
No. 1	Ø 1770	H 1010	Ø 1375	H 650	Ø 200	H 160
No. 2	Ø 1770	H 1190	Ø 1375	H 650	Ø 200	H 160
No. 3	Ø 1770	H 1370	Ø 1375	H 650	Ø 200	H 160
No. 4	Ø 1770	H 1480	Ø 1375	H 650	Ø 200	H 120

Diameter 2200

Meshes	A	B	C	D	E	F
No. 1	Ø 2240	H 1010	Ø 1970	H 650	Ø 300	H 160
No. 2	Ø 2240	H 1190	Ø 1970	H 650	Ø 300	H 160
No. 3	Ø 2240	H 1370	Ø 1970	H 650	Ø 300	H 160
No. 4	Ø 2240	H 1480	Ø 1970	H 650	Ø 300	H 120

ERIMAKI SNC di Cecilia Janni & C. - Via Timavo 36, 20037 Paderno Dugnano (Milan) - Italy

Phone +39 02.99044723 - +39 02.99044734 | Fax +039 02.99044729 | info@erimaki.it | www.erimaki.it

C.C.I.A.A 1169255 Codice Fiscale 07604340153 Partita IVA 02537230969