

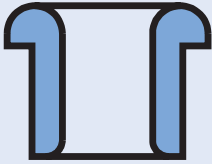

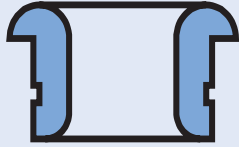

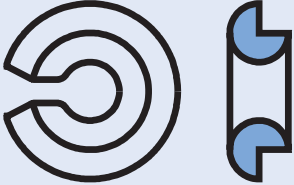

Ösen Eyelets

<p>Bundösen Straight shouldered eyelets</p>	<p>Bundösen mit Außenrinne Straight shouldered eyelets with external groove</p>
	
<p>Seite • Page 4 - 16</p>	<p>Seite • Page 17 - 20</p>
<p>Bundösen mit Schlitz Straight shouldered eyelets with slot</p>	<p>Zylindrische Ösen Cylindrical eyelets</p>
	
<p>Seite • Page 21 - 24</p>	<p>Seite • Page 25 - 32</p>
<p>Konische Ösen Tapered eyelets</p>	<p>Rillenösen Annular eyelets with groove</p>
	
<p>Seite • Page 33 - 36</p>	<p>Seite • Page 37 - 40</p>
<p>Spezialösen Special eyelets</p>	
	
<p>Seite • Page 41 - 45</p>	

Bundösen
Straight shouldered eyelets

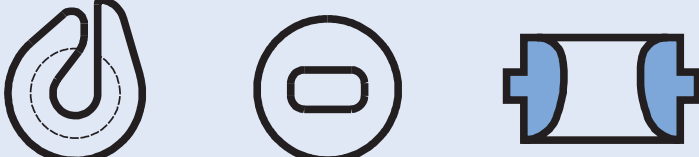
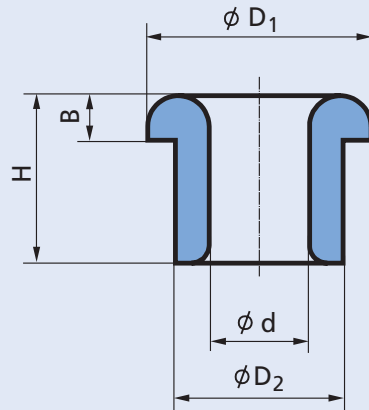

CeramTec Best. Nr. CeramTec ref.no.	Abmessungen (mm) Dimensions					Seite Page
	D ₁	D ₂	d	B	H	
30 3113 03	2,4	2,0	0,8	0,8	3,0	6
30 3113 01	2,5	2,0	0,8	1,5	8,0	6
30 3412 01	3,8	3,0	1,5	1,2	5,2	6
30 0162 00	4,0	3,0	1,5	1,0	3,0	6
30 3531 56	4,0	3,0	1,5	1,0	4,5	6
30 0104 02	4,8	4,0	2,1	1,4	5,0	6
30 3344 00	5,0	4,0	2,0	1,0	6,0	7
30 3531 65	6,0	4,0	0,3	1,0	4,0	7
30 3531 66	6,0	4,0	0,5	1,0	4,0	7
30 3531 67	6,0	4,0	0,75	1,0	4,0	7
30 3531 64	6,0	4,0	0,9	1,0	4,0	7
30 3234 00	6,0	4,6	2,4	1,2	5,1	7
30 0149 02	6,7	4,75	2,2	2,0	8,0	8
30 0105 00	7,0	5,0	2,0	1,8	4,0	8
30 0157 00	8,0	6,3	3,5	1,0	4,5	8
30 0155 00	8,0	6,4	3,5	2,0	10,0	8
30 0102 01	8,0	6,5	3,5	1,5	5,0	8
30 0102 00	8,0	6,5	3,5	1,5	6,5	8
30 0102 02	8,0	6,5	3,5	1,5	8,0	8
30 0121 00	9,0	7,0	2,5	3,0	5,0	9
30 3531 36	10,0	7,0	4,0	1,0	3,2	9
30 0101 00	9,0	7,5	4,5	2,0	7,0	8
30 0101 01	9,0	7,5	4,5	2,0	10,0	8
30 0151 00	9,5	7,5	5,5	2,4	13,5	9

Bundösen
Straight shouldered eyelets

MA070006-02 - D/GB - 300 - 0708 - Printed in Germany

CeramTec Best. Nr. CeramTec ref.no.	Abmessungen (mm) Dimensions					Seite Page
	D ₁	D ₂	d	B	H	
30 3440 00	10,0	7,5	4,5	2,0	7,5	9
30 3486 00	10,0	8,0	4,0	1,0	5,0	9
30 3207 00	10,0	8,0	4,5	2,0	15,0	9
30 3531 63	13,0	9,0	4,0	2,0	7,0	10
30 3248 00	11,8	9,2	5,6	1,8	8,7	10
30 3531 62	11,9	9,5	5,5	2,4	8,2	10
30 3383 00	12,8	9,5	3,8	2,0	7,0	10
30 3414 00	10,8	9,8	6,5	1,0	6,0	10
30 0184 00	12,0	10,0	5,0	4,0	29,0	10
30 3116 00	14,0	10,0	5,0	4,0	20,0	11
30 0141 00	14,0	10,0	5,5	2,0	9,0	11
30 0148 00	14,0	11,0	6,5	2,5	12,0	11
30 3251 00	14,0	11,5	5,5	2,0	5,0	11
30 0123 00	14,0	11,5	5,5	2,0	9,0	11
30 0165 00	15,0	12,0	8,0	3,0	12,5	12
30 3239 03	16,0	12,0	6,0	2,5	8,0	12
30 3239 02	16,0	12,0	6,0	2,5	15,0	12
30 3136 00	16,0	12,0	7,0	3,0	10,5	12
30 3239 04	16,0	12,0	8,0	2,5	8,0	12
30 3257 00	17,0	12,0	7,0	5,0	20,0	12
30 3164 00	17,5	12,0	7,5	4,5	13,7	12
30 3531 22	13,5	12,3	6,5	2,0	7,0	11
30 3531 23	13,5	12,3	8,5	2,0	7,0	11
30 3522 00	18,0	13,0	7,0	3,0	11,0	13
30 3318 02	20,0	13,5	7,5	5,0	10,0	13
30 3522 02	17,8	13,7	7,0	3,0	11,0	13
30 3245 00	23,0	14,9	10,0	5,0	20,0	13
30 3142 00	20,0	15,0	7,0	4,0	16,0	13
30 3377 00	30,0	20,0	15,0	5,0	15,0	14
30 3531 53	28,0	23,0	16,0	3,0	11,0	13
30 3531 21	28,0	24,0	16,0	3,0	11,0	13
30 3531 54	58,0	50,0	15,0	19,0	50,0	14
30 3531 55	72,0	50,5	10,0	23,0	40,0	15
30 3531 58	72,0	50,5	17,0	23,0	103,0	15
30 3531 73	63,5	57,2	50,8	6,4	19,1	14
30 3531 38	95,0	68,0	48,0	19,0	100,0	15

Bundlösen
Straight shouldered eyelets

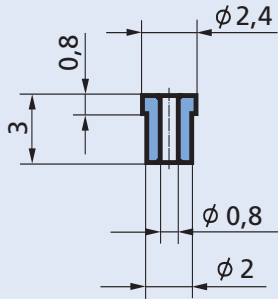

M 3:1

CeramTec Best. Nr.
CeramTec ref.no.

30 3113 03

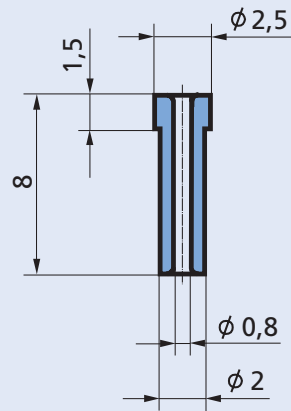

M 3:1

CeramTec Best. Nr.
CeramTec ref.no.

30 3113 01

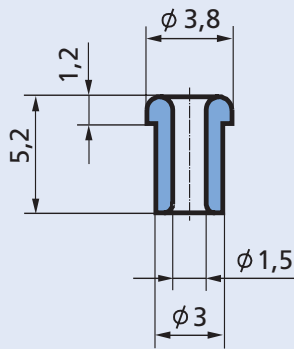

M 3:1

CeramTec Best. Nr.
CeramTec ref.no.

30 3412 01

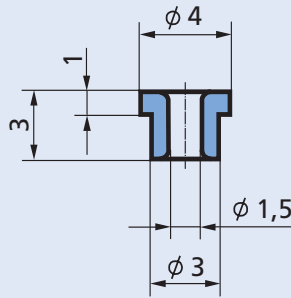

M 3:1

CeramTec Best. Nr.
CeramTec ref.no.

30 0162 00

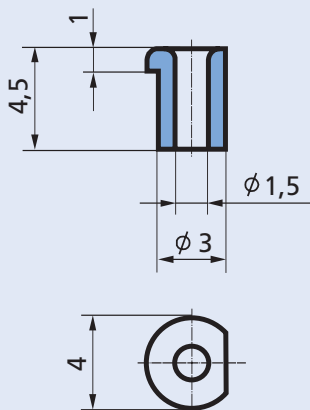

M 3:1

CeramTec Best. Nr.
CeramTec ref.no.

30 3531 56

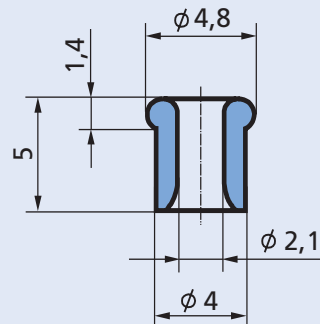

M 3:1

CeramTec Best. Nr.
CeramTec ref.no.

30 0104 02

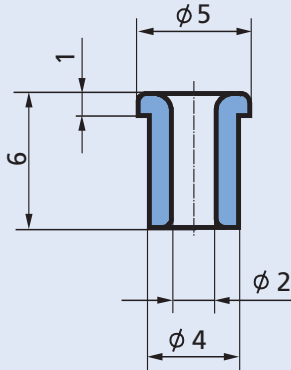

M 3:1

CeramTec Best. Nr.
CeramTec ref.no.

30 3344 00

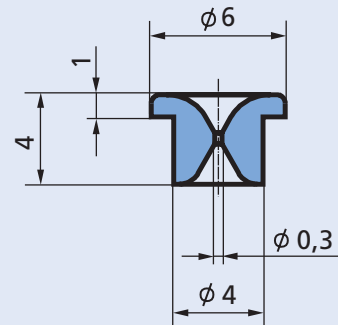

M 3:1

CeramTec Best. Nr.
CeramTec ref.no.

30 3531 65

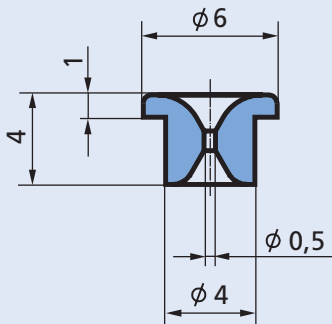

M 3:1

CeramTec Best. Nr.
CeramTec ref.no.

30 3531 66

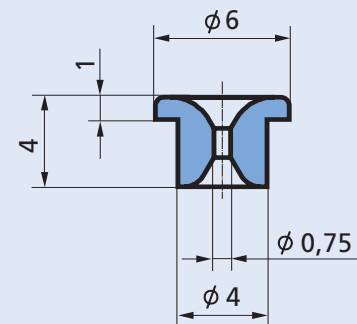

M 3:1

CeramTec Best. Nr.
CeramTec ref.no.

30 3531 67

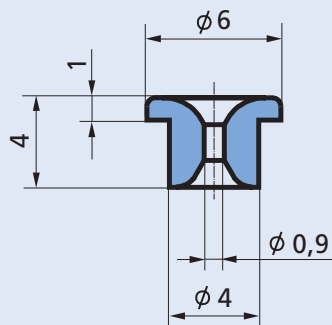

M 3:1

CeramTec Best. Nr.
CeramTec ref.no.

30 3531 64

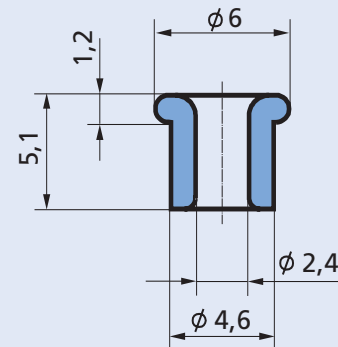

M 3:1

CeramTec Best. Nr.
CeramTec ref.no.

30 3234 00

Bundösen
Straight shouldered eyelets

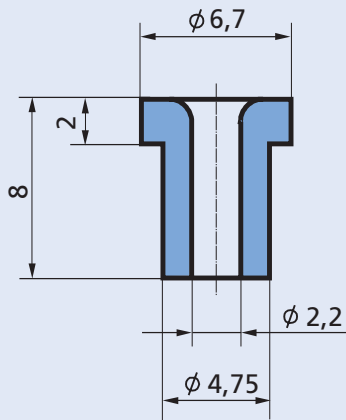

M 3:1

CeramTec Best. Nr. 30 0149 02
CeramTec ref.no.

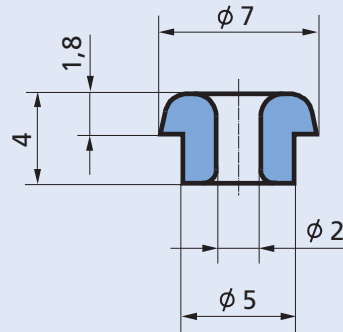

M 3:1

CeramTec Best. Nr. 30 0105 00
CeramTec ref.no.

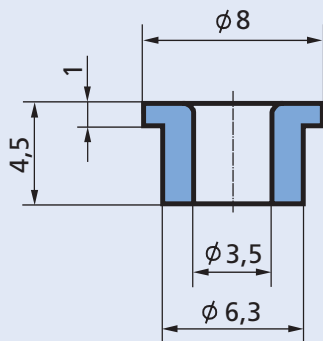

M 3:1

CeramTec Best. Nr. 30 0157 00
CeramTec ref.no.

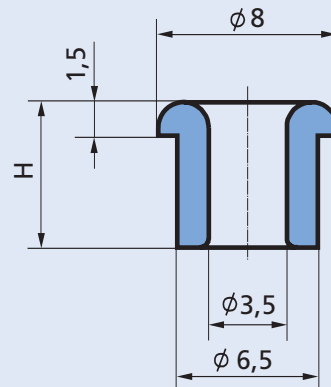

M 3:1

CeramTec Best. Nr. H = 5,0 30 0102 01
CeramTec ref.no. H = 6,5 30 0102 00
H = 8,0 30 0102 02

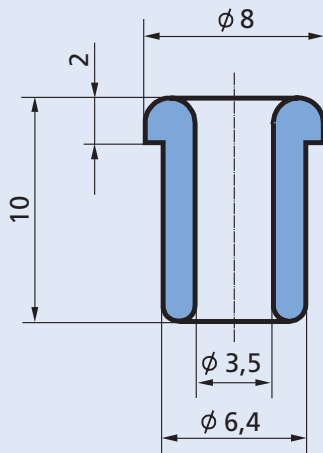

M 3:1

CeramTec Best. Nr. 30 0155 00
CeramTec ref.no.

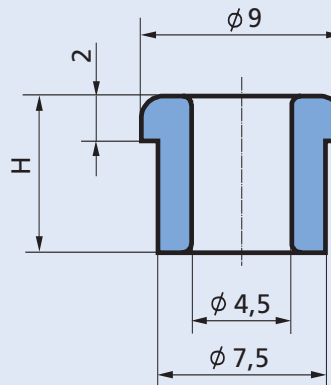

M 3:1

CeramTec Best. Nr. H = 7 30 0101 00
CeramTec ref.no. H = 10 30 0101 01

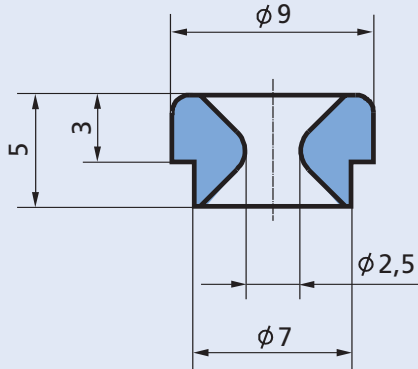

M 3:1

CeramTec Best. Nr.
CeramTec ref.no.

30 0121 00

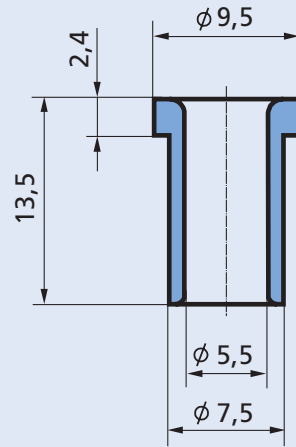

M 3:1

CeramTec Best. Nr.
CeramTec ref.no.

30 0151 00

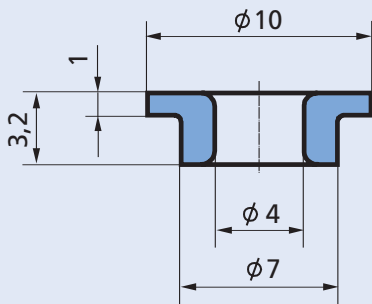

M 3:1

CeramTec Best. Nr.
CeramTec ref.no.

30 3531 36

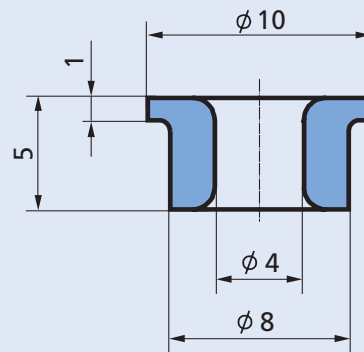

M 3:1

CeramTec Best. Nr.
CeramTec ref.no.

30 3486 00

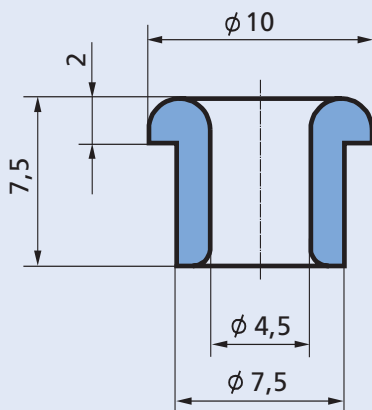

M 3:1

CeramTec Best. Nr.
CeramTec ref.no.

30 3440 00

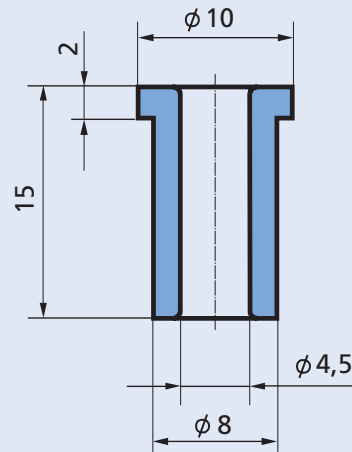

M 2:1

CeramTec Best. Nr.
CeramTec ref.no.

30 3207 00

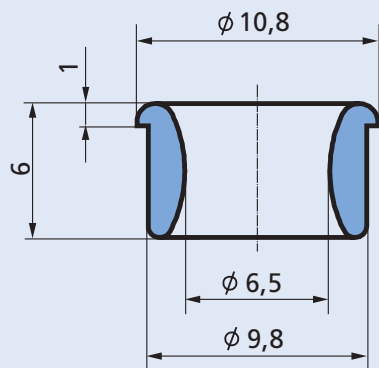

M 3:1

CeramTec Best. Nr.
CeramTec ref.no.

30 3414 00

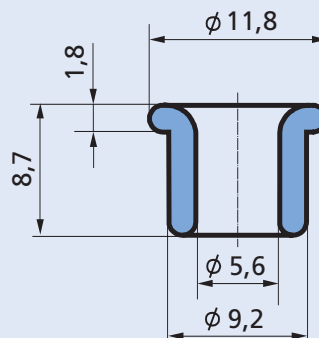

M 2:1

CeramTec Best. Nr.
CeramTec ref.no.

30 3248 00

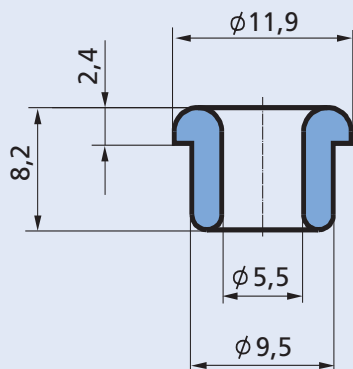

M 2:1

CeramTec Best. Nr.
CeramTec ref.no.

30 3531 62

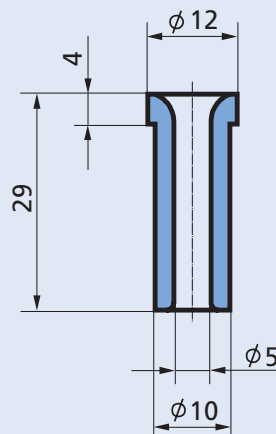

M 1:1

CeramTec Best. Nr.
CeramTec ref.no.

30 0184 00

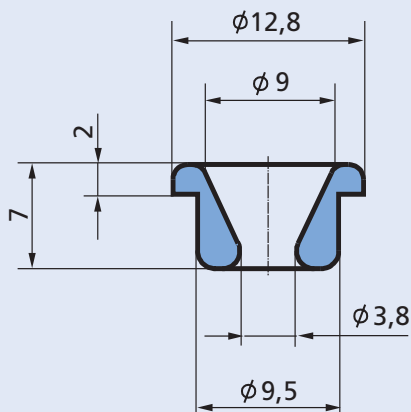

M 2:1

CeramTec Best. Nr.
CeramTec ref.no.

30 3383 00

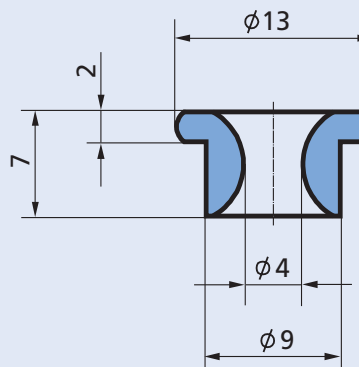

M 2:1

CeramTec Best. Nr.
CeramTec ref.no.

30 3531 63

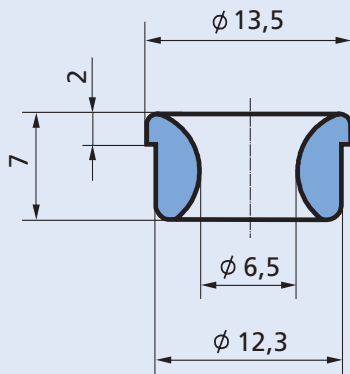

M 2:1

CeramTec Best. Nr.
CeramTec ref.no.

30 3531 22

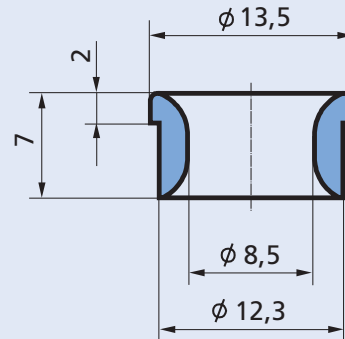

M 2:1

CeramTec Best. Nr.
CeramTec ref.no.

30 3531 23

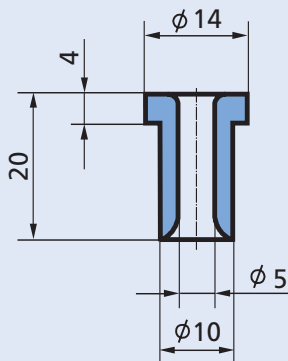

M 1:1

CeramTec Best. Nr.
CeramTec ref.no.

30 3116 00

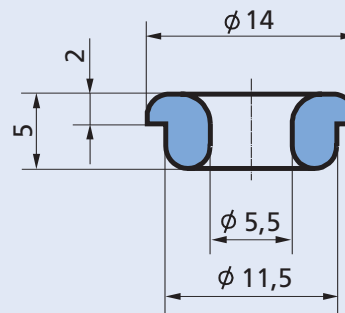

M 2:1

CeramTec Best. Nr.
CeramTec ref.no.

30 3251 00

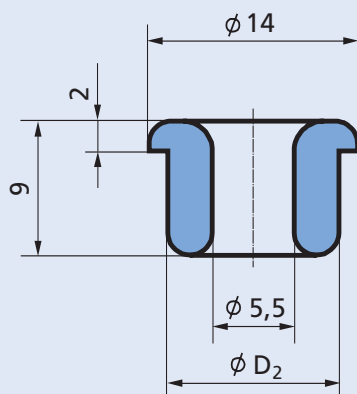

M 2:1

CeramTec Best. Nr.
CeramTec ref.no.

D₂ = 10,0 30 0141 00
D₂ = 11,5 30 0123 00

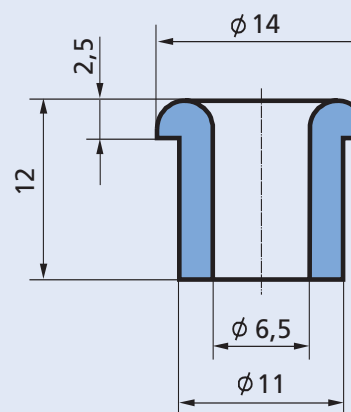

M 2:1

CeramTec Best. Nr.
CeramTec ref.no.

30 0148 00

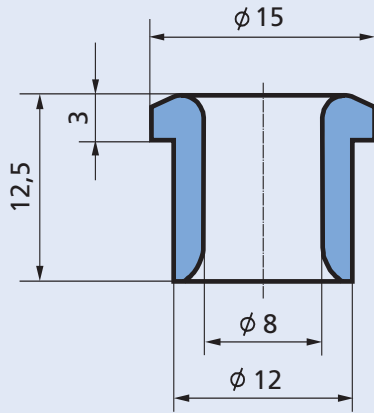

M 2:1

CeramTec Best. Nr.
CeramTec ref.no.

30 0165 00

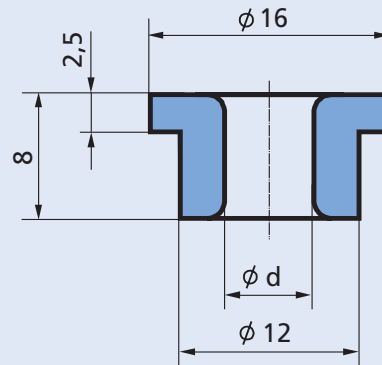

M 2:1

CeramTec Best. Nr.
CeramTec ref.no.

d = 6,0 30 3239 03
d = 8,0 30 3239 04

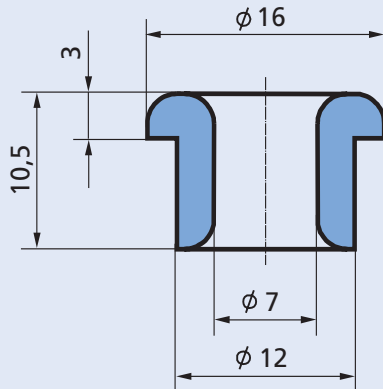

M 2:1

CeramTec Best. Nr.
CeramTec ref.no.

30 3136 00

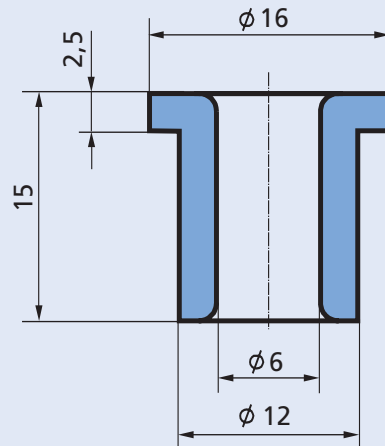

M 2:1

CeramTec Best. Nr.
CeramTec ref.no.

30 3239 02

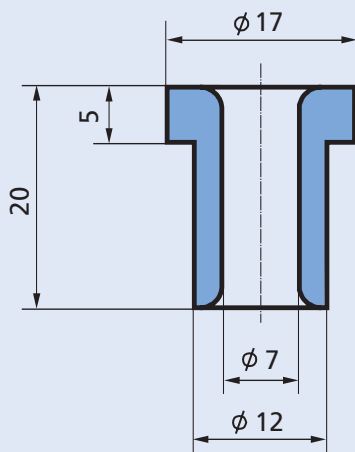

M 2:1

CeramTec Best. Nr.
CeramTec ref.no.

30 3257 00

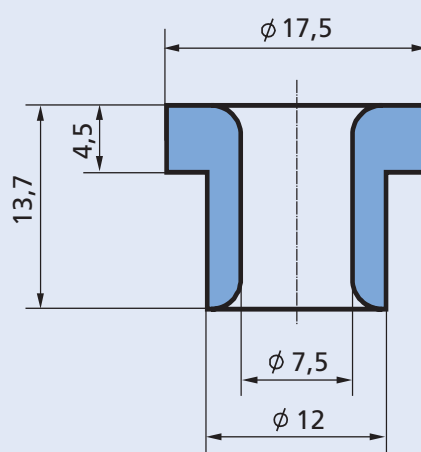

M 2:1

CeramTec Best. Nr.
CeramTec ref.no.

30 3164 00

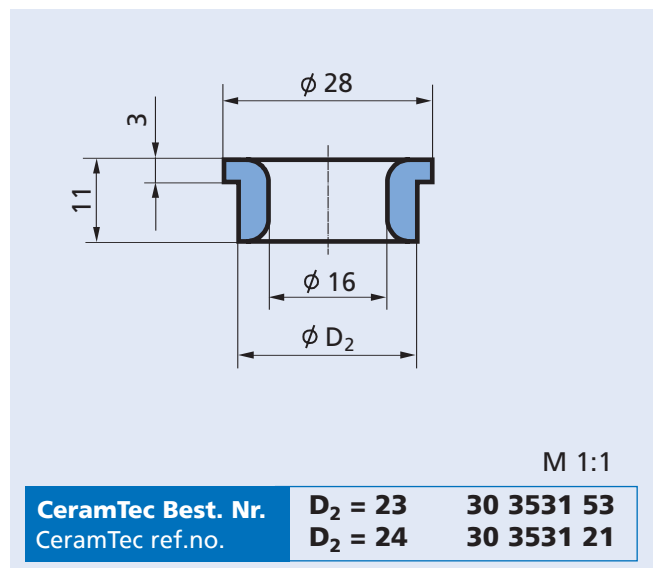
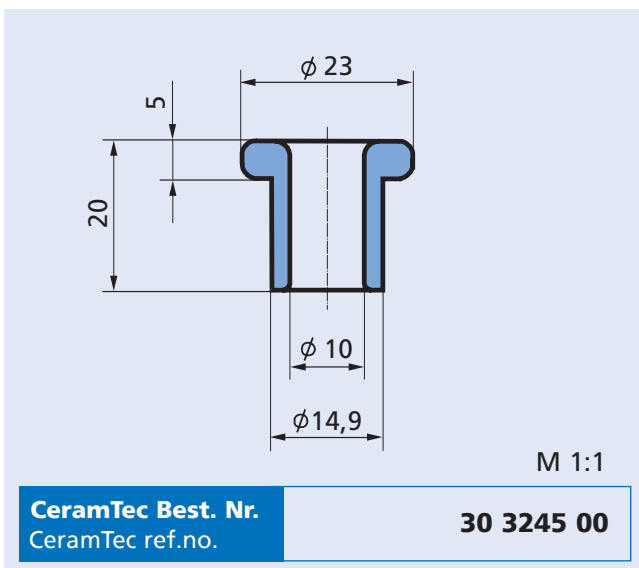
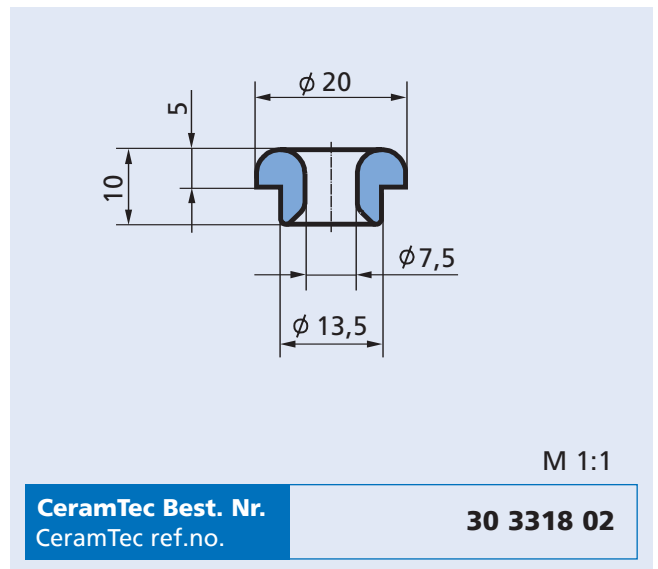
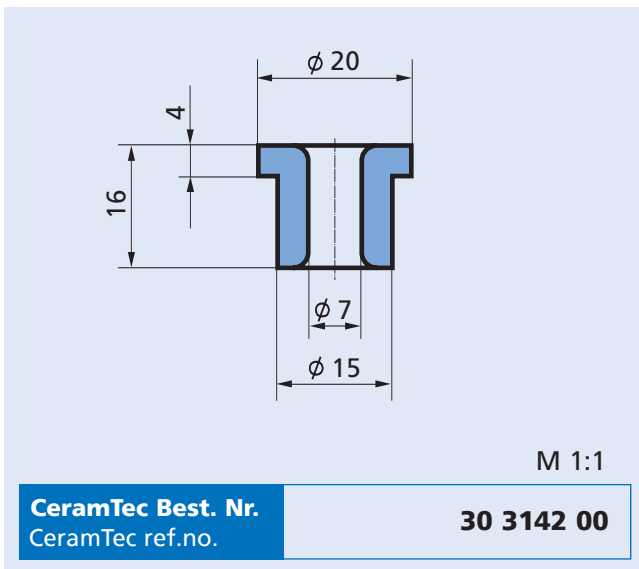
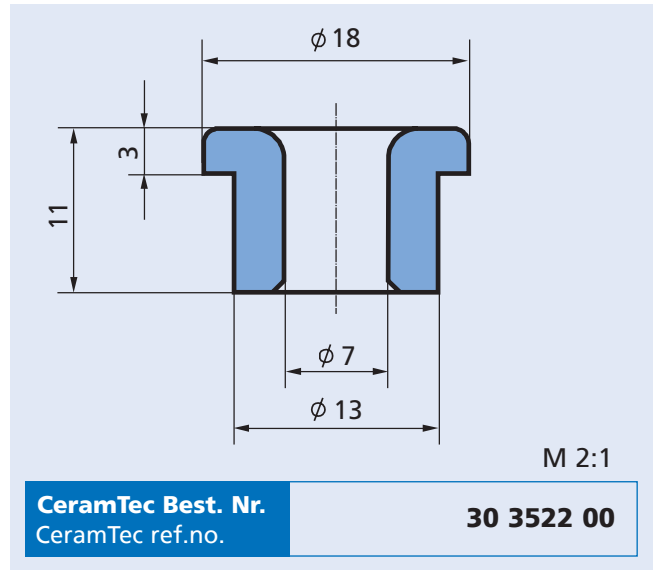
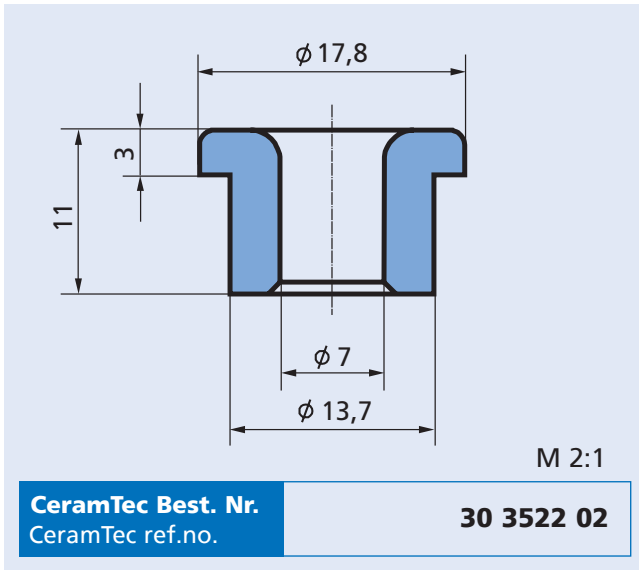

Bundösen
Straight shouldered eyelets

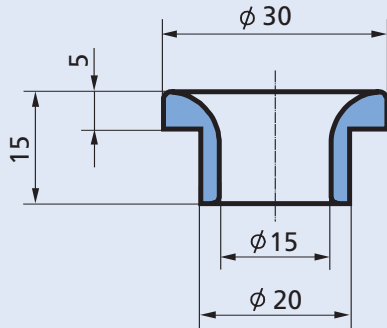

M 1:1

CeramTec Best. Nr.
CeramTec ref.no.

30 3377 00

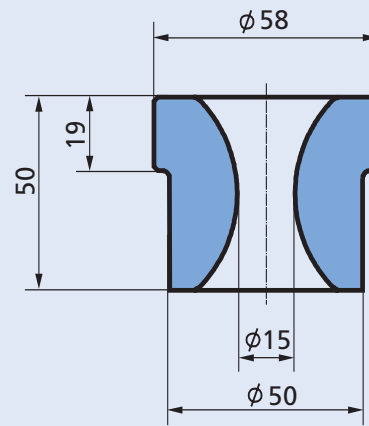

M 1:2

CeramTec Best. Nr.
CeramTec ref.no.

30 3531 54

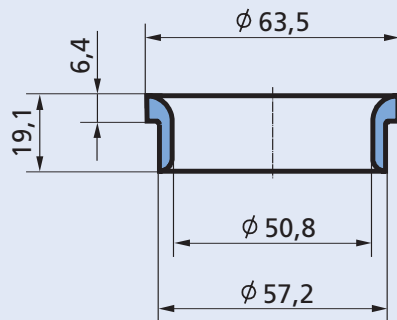

M 1:2

CeramTec Best. Nr.
CeramTec ref.no.

30 3531 73

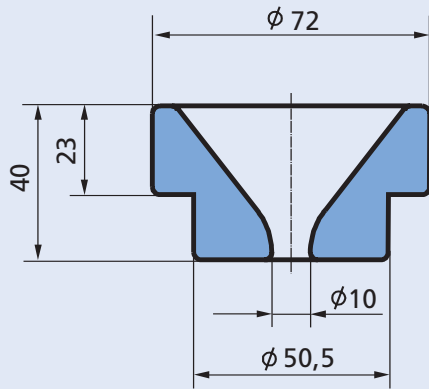

M 1:2

CeramTec Best. Nr.
CeramTec ref.no.

30 3531 55

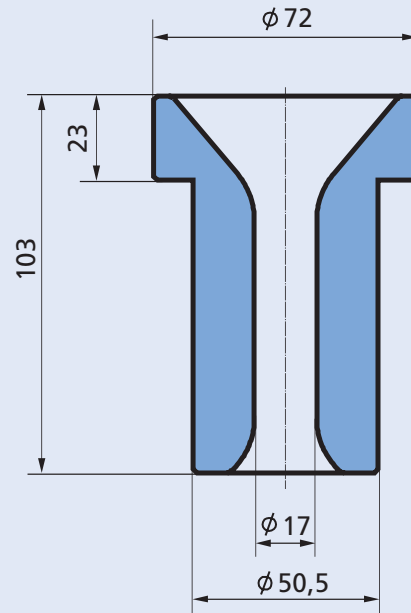

M 1:2

CeramTec Best. Nr.
CeramTec ref.no.

30 3531 58

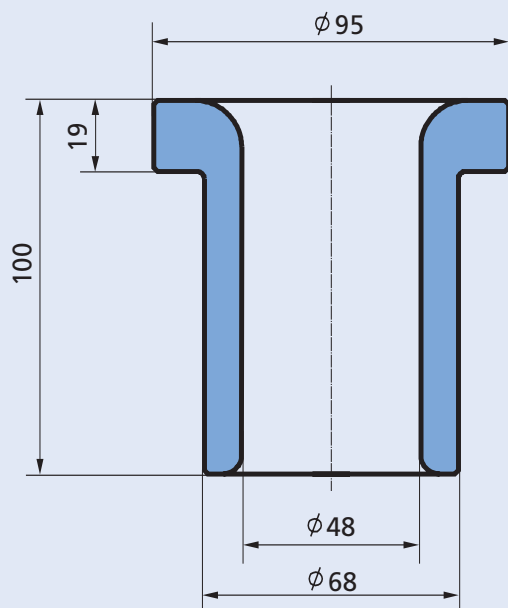

M 1:2

CeramTec Best. Nr.
CeramTec ref.no.

30 3531 38

Bundösen mit Außenrille
Straight shouldered eyelets with external groove

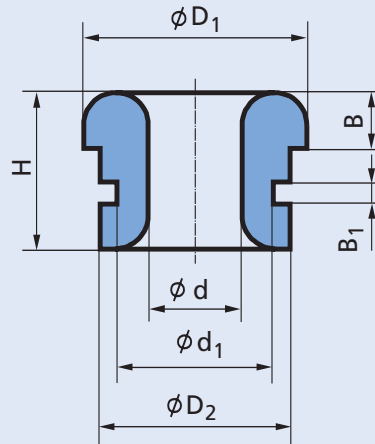

CeramTec Best. Nr. CeramTec ref.no.	Abmessungen (mm) Dimensions							Seite Page
	D ₁	D ₂	d	B	d ₁	B ₁	H	
30 3531 61	6,6	5,0	3,0	1,85	4,2	1,2	5,9	18
30 3237 00	9,0	7,0	4,0	2,5	6,0	1,0	11,5	18
30 0108 02	10,0	8,5	4,2	1,5	7,0	1,0	7,0	18
30 3384 00	12,7	9,6	4,8	1,7	8,0	1,0	9,0	18
30 3531 32	12,0	10,0	1,0	2,0	7,7	1,5	7,0	18
30 3531 57	12,0	10,0	2,0	2,0	7,6	1,5	7,0	18
30 3240 00	15,5	11,5	6,5	2,5	9,5	2,0	10,0	19
30 0189 00	18,0	11,5	4,8	4,0	10,0	1,5	32,0	19
30 0152 00	19,0	13,0	6,0	5,0	12,0	2,0	10,0	19
30 3332 00	19,0	15,0	9,0	2,5	14,0	1,3	10,0	19
30 3531 33	20,0	15,0	9,0	3,0	12,0	1,5	13,5	19
30 3170 00	32,0	23,0	12,0	3,0	21,0	1,3	15,0	19
30 3381 00	35,0	30,0	20,0	4,0	28,6	1,5	12,0	20
30 3381 01	40,0	30,0	20,0	5,0	26,0	4,2	21,0	20
30 3531 26	57,0	50,3	38,2	6,0	46,9	2,1	19,0	20

Bundösen mit Außenrille
Straight shouldered eyelets
with external groove

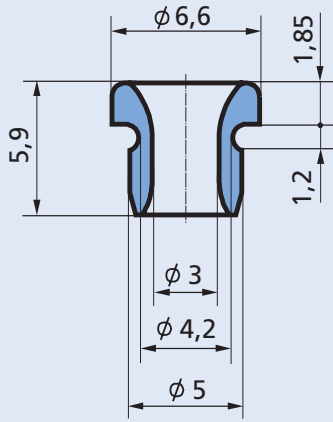

M 3:1

CeramTec Best. Nr.
CeramTec ref.no.

30 3531 61

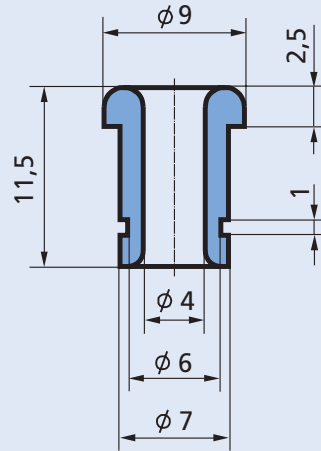

M 2:1

CeramTec Best. Nr.
CeramTec ref.no.

30 3237 00

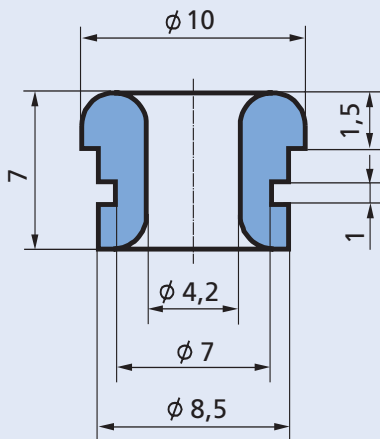

M 3:1

CeramTec Best. Nr.
CeramTec ref.no.

30 0108 02

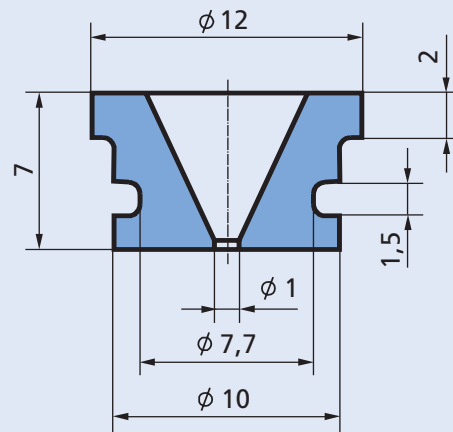

M 3:1

CeramTec Best. Nr.
CeramTec ref.no.

30 3531 32

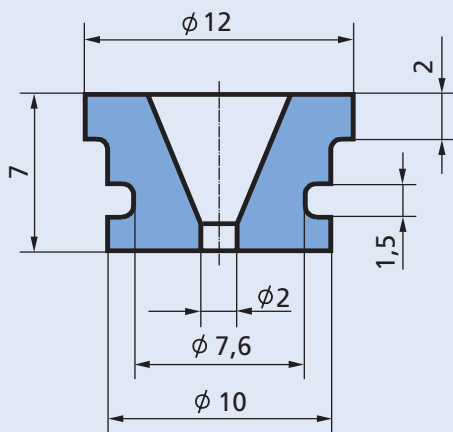

M 3:1

CeramTec Best. Nr.
CeramTec ref.no.

30 3531 57

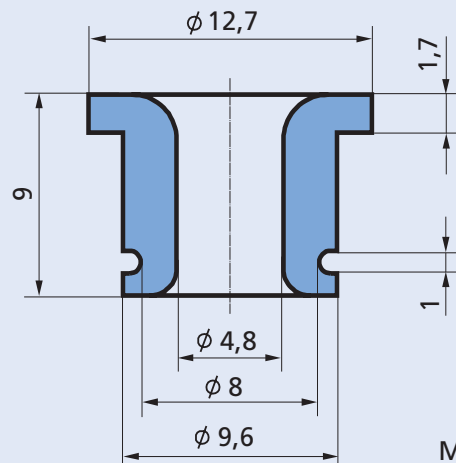

M 3:1

CeramTec Best. Nr.
CeramTec ref.no.

30 3384 00

Bundösen mit Außenrille
Straight shouldered eyelets
with external groove

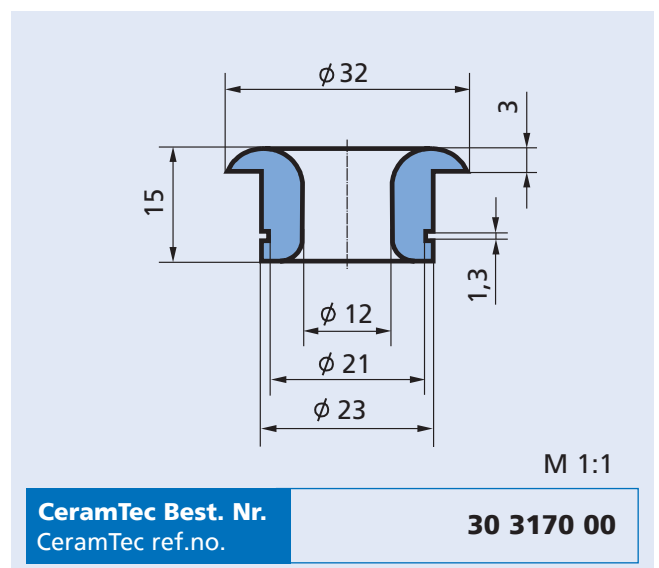
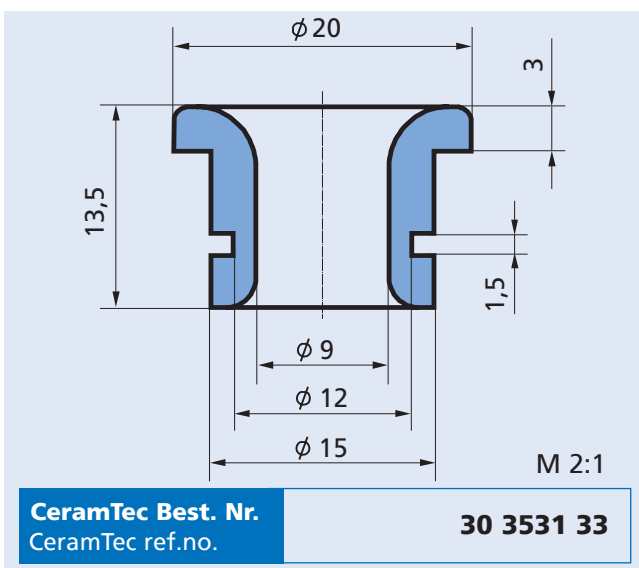
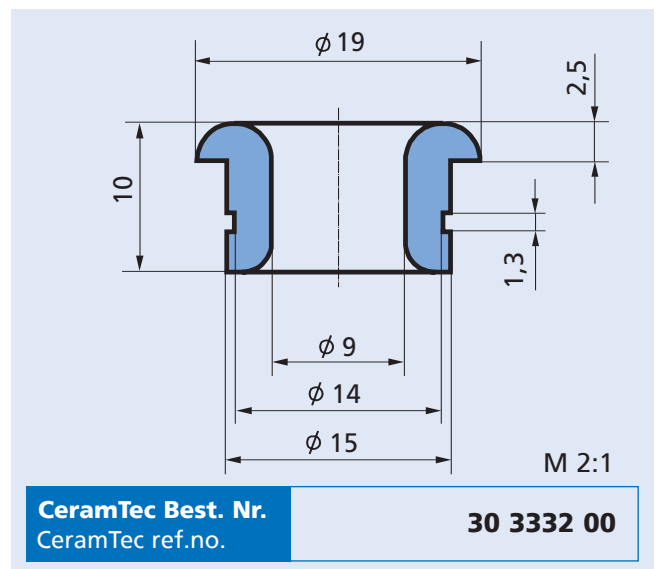
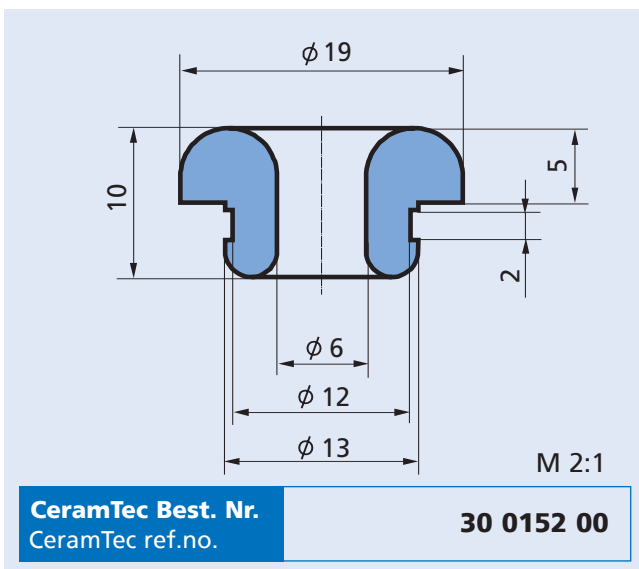
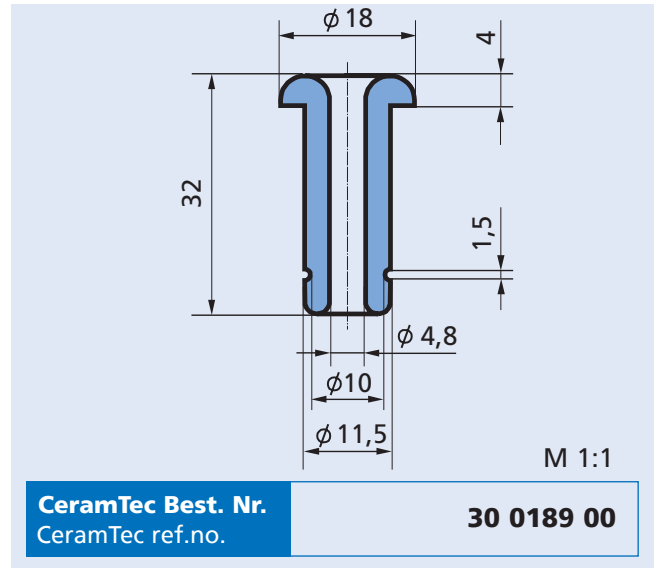
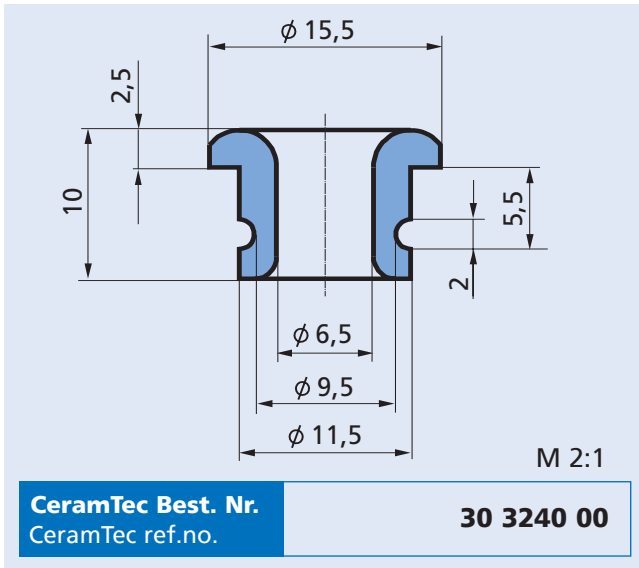

Bundösen mit Außenrinne
Straight shouldered eyelets
with external groove

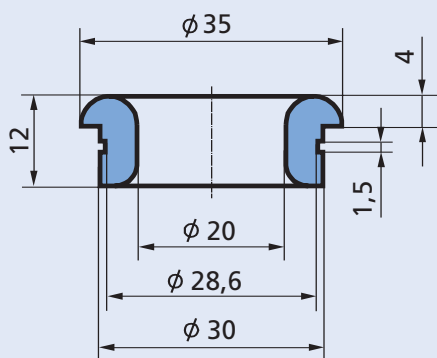

M 1:1

CeramTec Best. Nr.
CeramTec ref.no.

30 3381 00

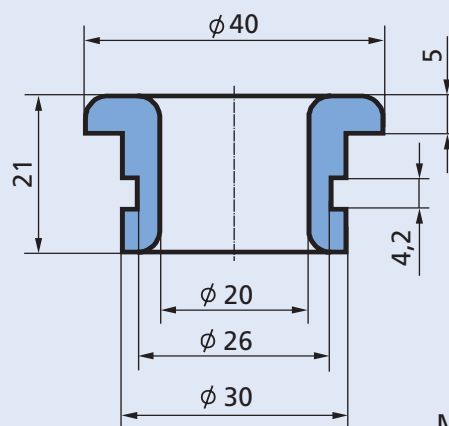

M 1:1

CeramTec Best. Nr.
CeramTec ref.no.

30 3381 01

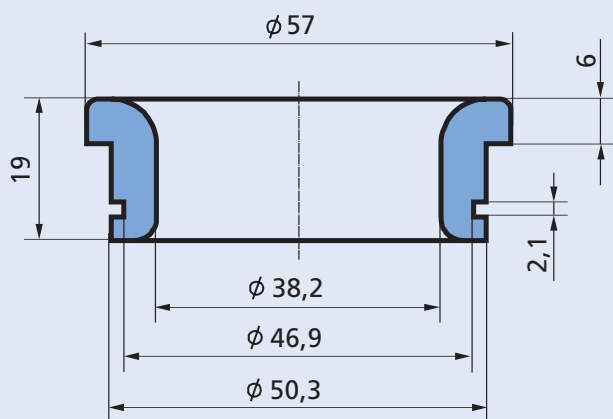

M 1:1

CeramTec Best. Nr.
CeramTec ref.no.

30 3531 26

Bundösen mit Außenrille
Straight shouldered eyelets
with external groove

Bundösen mit Schlitz
Straight shouldered eyelets with slot

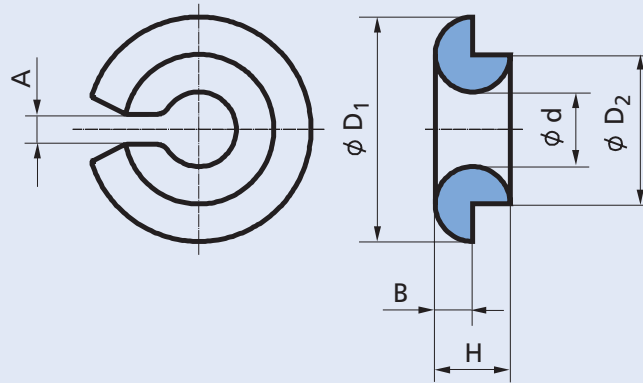

CeramTec Best. Nr. CeramTec ref.no.	Abmessungen (mm) Dimensions						Seite Page
	D ₁	D ₂	B	d	A	H	
30 3531 75	7,0	3,0	1,1	1,8	1,0	3,8	22
30 3531 70	5,3	3,5	1,0	1,8	0,8	4,0	22
30 3531 31	5,3	3,6	1,0	2,0	1,0	2,5	22
30 3144 00	7,0	4,0	1,0	1,5	0,6	2,0	22
30 3417 00	8,0	6,0	1,0	2,0	2,0	2,1	23
30 3424 00	8,0	6,0	1,0	-	1,0	2,8	23
30 0131 01	9,5	7,5	2,0	2,0	2,0	5,5	23
30 0131 00	9,5	7,5	2,0	3,5	3,5	5,5	23
30 3267 00	9,7	7,6	1,75	3,2	2,2	7,75	23
30 0160 00	15,0	10,0	2,5	5,0	2,0	5,0	24

Bundösen mit Schlitz
Straight shouldered eyelets with slot

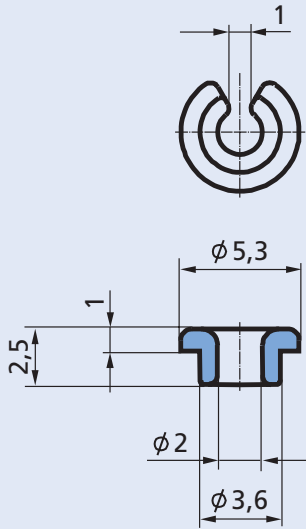

M 3:1

CeramTec Best. Nr.
CeramTec ref.no.

30 3531 31

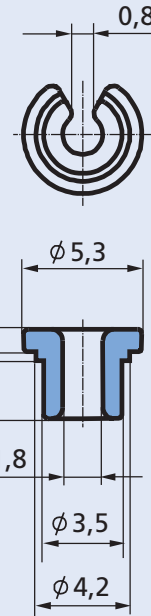

M 3:1

CeramTec Best. Nr.
CeramTec ref.no.

30 3531 70

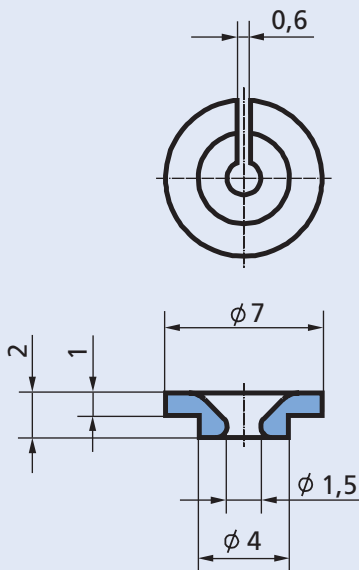

M 3:1

CeramTec Best. Nr.
CeramTec ref.no.

30 3144 00

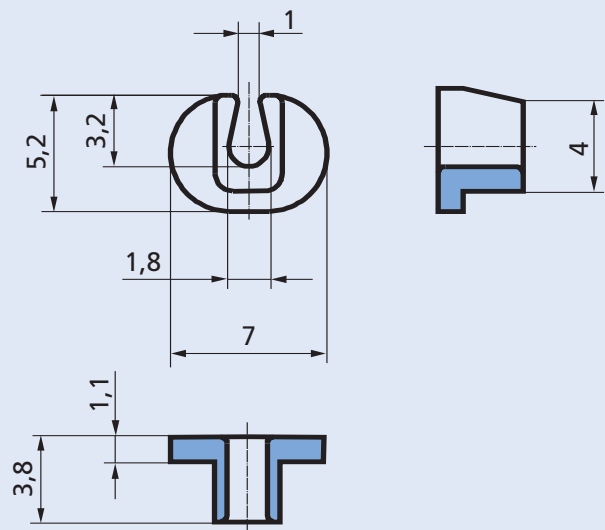

M 3:1

CeramTec Best. Nr.
CeramTec ref.no.

30 3531 75

Bundösen mit Schlitz
Straight shouldered eyelets with slot

MA070006-11 · D/GB · 300 · 0708 · Printed in Germany

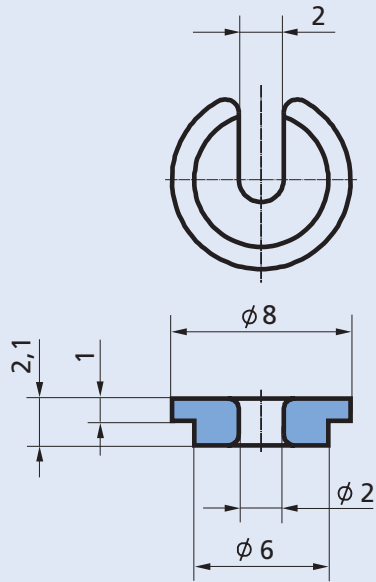

M 3:1

CeramTec Best. Nr.
CeramTec ref.no.

30 3417 00

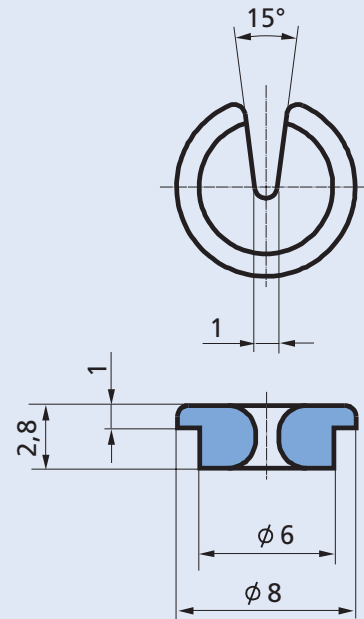

M 3:1

CeramTec Best. Nr.
CeramTec ref.no.

30 3424 00

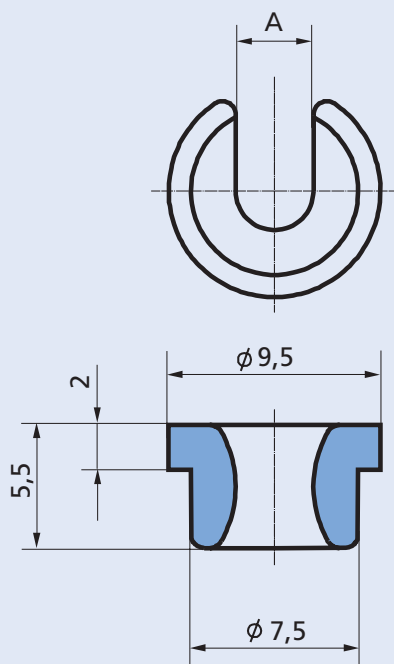

M 3:1

CeramTec Best. Nr.
CeramTec ref.no.

A = 2,0 30 0131 01
A = 3,5 30 0131 00

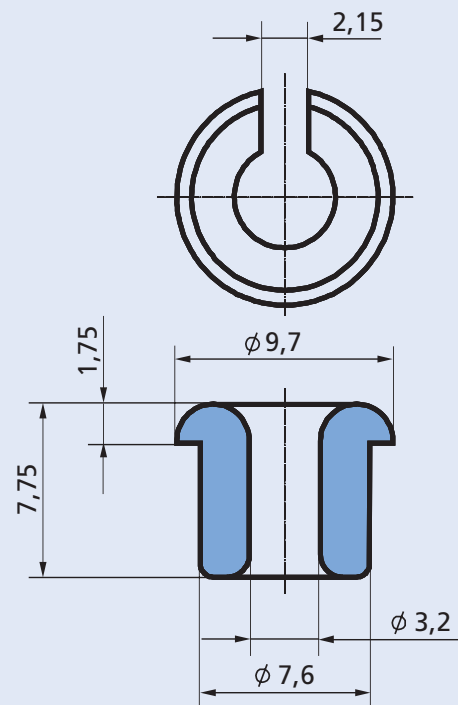

M 3:1

CeramTec Best. Nr.
CeramTec ref.no.

30 3267 00

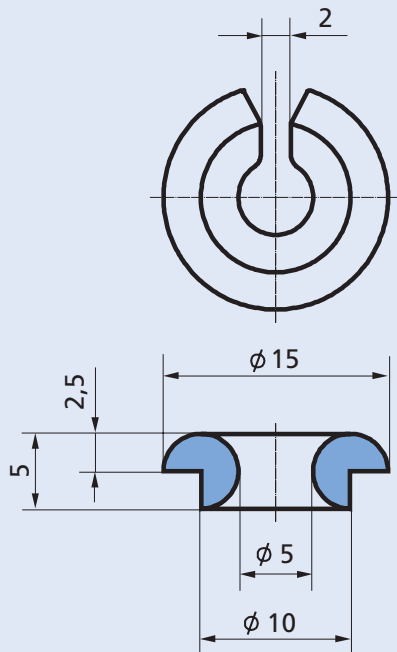

M 2:1

CeramTec Best. Nr.
CeramTec ref.no.

30 0160 00

Bundösen mit Schlitz
Straight shouldered eyelets with slot

Zylindrische Ösen
Cylindrical eyelets

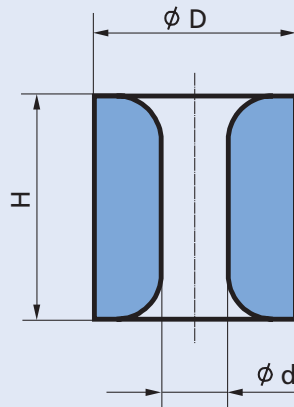

CeramTec Best. Nr. CeramTec ref.no.	Abmessungen (mm) Dimensions			Seite Page	CeramTec Best. Nr. CeramTec ref.no.	Abmessungen (mm) Dimensions			Seite Page
	D	d	H			D	d	H	
30 3208 00	4,0	1,8	7,8	26	30 3531 35	12,0	6,0	12,0	28
30 0167 01	6,0	3,0	6,0	26	30 3129 00	12,0	7,0	7,0	29
30 0130 00	7,5	4,0	3,9	26	30 3201 00	12,0	7,0	8,0	29
30 3197 00	8,0	3,5	10,5	26	30 3115 00	13,0	5,5	6,0	29
30 0195 01	8,0	5,0	8,0	26	30 3115 01	13,0	7,0	6,0	29
30 3531 49	8,5	4,0	14,0	26	30 3531 25	13,0	7,0	6,0	29
30 3152 13	9,0	1,4	10,0	27	30 3531 45	13,0	8,0	19,0	29
30 3152 03	9,0	1,75	10,0	27	30 3531 44	14,0	8,0	19,0	29
30 3152 04	9,0	2,25	10,0	27	30 3531 68	15,0	10,0	20,0	30
30 3152 14	9,0	2,5	10,0	27	30 3531 37	16,0	10,0	5,0	30
30 3152 01	9,0	3,0	10,0	27	30 3531 43	16,0	10,0	19,0	30
30 3152 11	9,0	3,5	10,0	27	30 3202 00	16,0	10,0	10,0	30
30 3152 02	9,0	4,0	10,0	27	30 0139 00	18,5	12,0	12,0	30
30 3152 15	9,0	4,25	10,0	27	30 3531 42	19,1	12,0	17,0	30
30 0154 00	9,0	5,5	3,5	27	30 3114 00	20,0	10,0	18,0	31
30 3531 48	9,5	6,0	15,0	27	30 3203 00	20,0	12,0	12,0	31
30 3378 00	10,0	5,0	5,0	27	30 3531 41	22,3	16,0	24,0	31
30 3200 00	10,0	5,0	6,0	27	30 3531 50	25,0	1,5	17,0	31
30 3531 74	10,0	6,0	8,0	28	30 3531 51	25,0	2,5	17,0	31
30 3119 00	10,0	6,0	8,0	28	30 3160 00	25,0	15,0	17,0	31
30 3531 47	10,6	6,0	15,0	28	30 3530 10	26,0	12,0	12,0	31
30 3525 00	11,0	8,0	7,0	28	30 3531 40	28,9	20,0	21,0	32
30 3531 46	11,7	6,0	15,0	28	30 3531 39	35,0	27,0	30,0	32

Zylindrische Ösen
Cylindrical eyelets

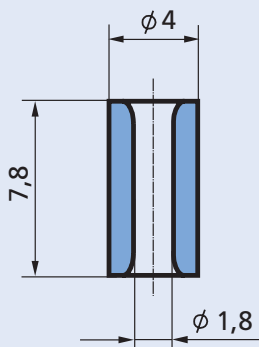

M 3:1

CeramTec Best. Nr.
CeramTec ref.no.

30 3208 00

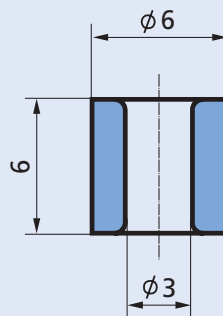

M 3:1

CeramTec Best. Nr.
CeramTec ref.no.

30 0167 01

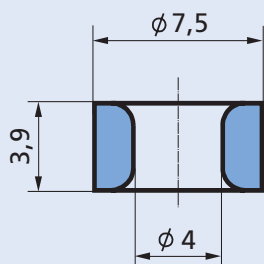

M 3:1

CeramTec Best. Nr.
CeramTec ref.no.

30 0130 00

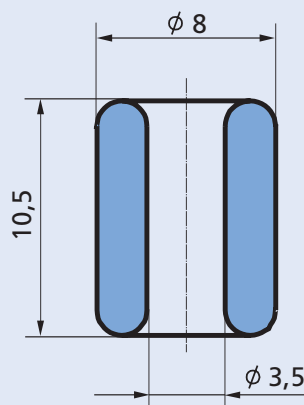

M 3:1

CeramTec Best. Nr.
CeramTec ref.no.

30 3197 00

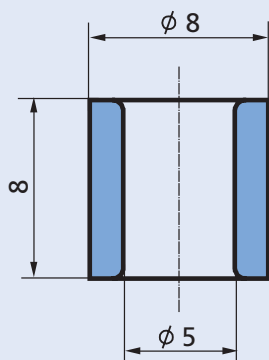

M 3:1

CeramTec Best. Nr.
CeramTec ref.no.

30 0195 01

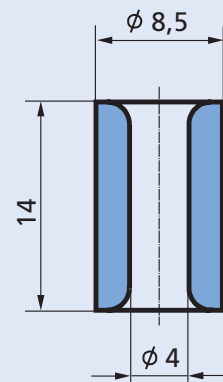

M 2:1

CeramTec Best. Nr.
CeramTec ref.no.

30 3531 49

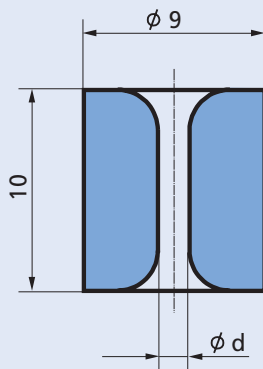

M 3:1

CeramTec Best. Nr.
CeramTec ref.no.

d = 1,4	30 3152 13
d = 1,75	30 3152 03
d = 2,25	30 3152 04
d = 2,5	30 3152 14

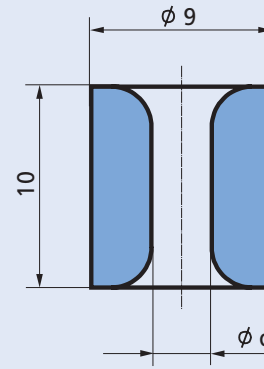

M 3:1

CeramTec Best. Nr.
CeramTec ref.no.

d = 3,0	30 3152 01
d = 3,5	30 3152 11
d = 4,0	30 3152 02
d = 4,25	30 3152 15

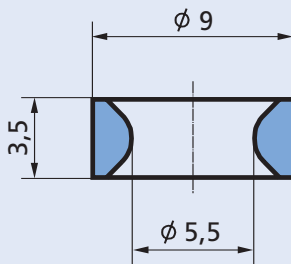

M 3:1

CeramTec Best. Nr.
CeramTec ref.no.

30 0154 00

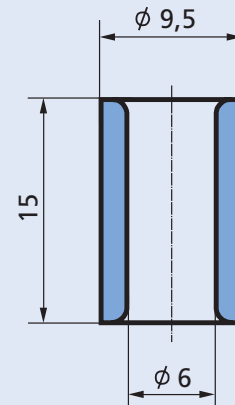

M 2:1

CeramTec Best. Nr.
CeramTec ref.no.

30 3531 48

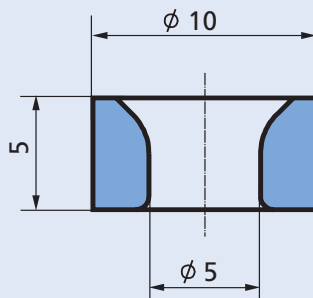

M 3:1

CeramTec Best. Nr.
CeramTec ref.no.

30 3378 00

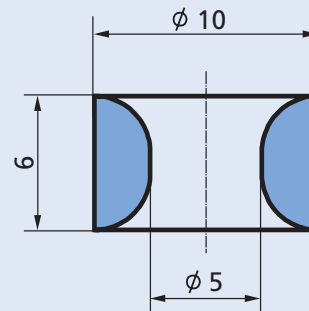

M 3:1

CeramTec Best. Nr.
CeramTec ref.no.

30 3200 00

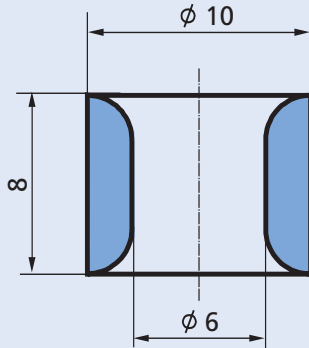

M 3:1

CeramTec Best. Nr.
CeramTec ref.no.

30 3531 74

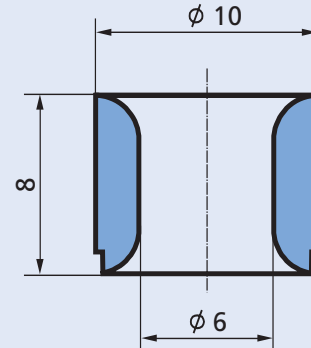

M 3:1

CeramTec Best. Nr.
CeramTec ref.no.

30 3119 00

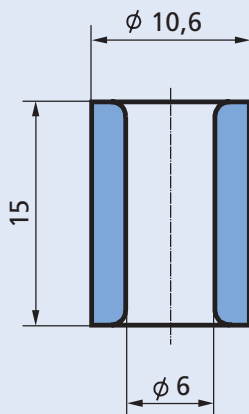

M 2:1

CeramTec Best. Nr.
CeramTec ref.no.

30 3531 47

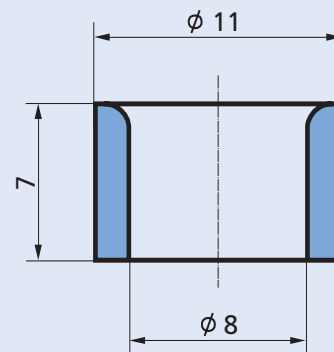

M 3:1

CeramTec Best. Nr.
CeramTec ref.no.

30 3525 00

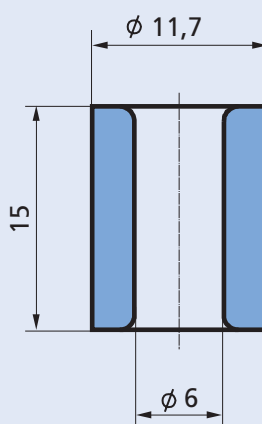

M 2:1

CeramTec Best. Nr.
CeramTec ref.no.

30 3531 46

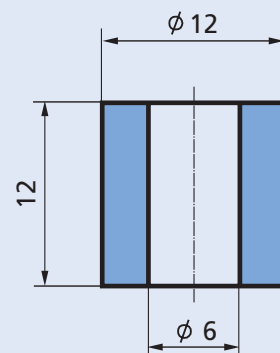

M 2:1

CeramTec Best. Nr.
CeramTec ref.no.

30 3531 35

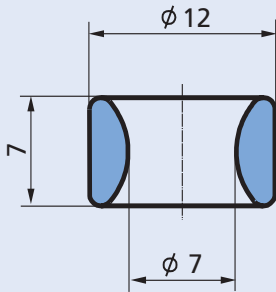

M 2:1

CeramTec Best. Nr.
CeramTec ref.no.

30 3129 00

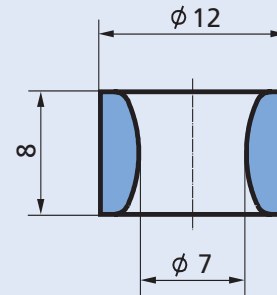

M 2:1

CeramTec Best. Nr.
CeramTec ref.no.

30 3201 00

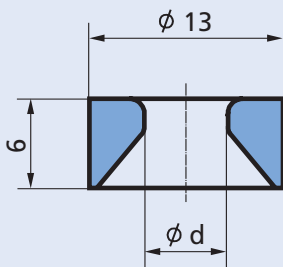

M 2:1

CeramTec Best. Nr.
CeramTec ref.no.

d = 5,5 30 3115 00
d = 7,0 30 3115 01

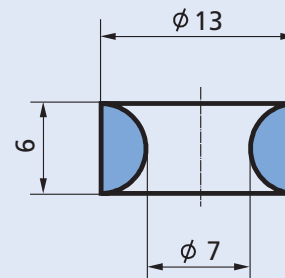

M 2:1

CeramTec Best. Nr.
CeramTec ref.no.

30 3531 25

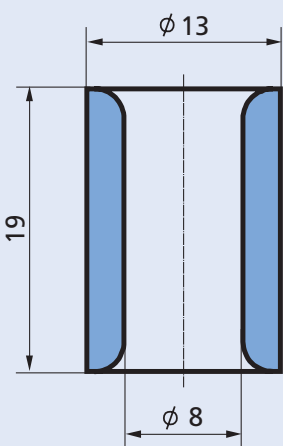

M 2:1

CeramTec Best. Nr.
CeramTec ref.no.

30 3531 45

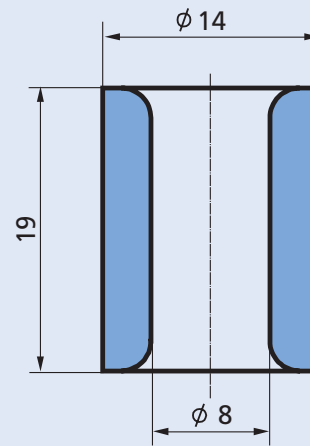

M 2:1

CeramTec Best. Nr.
CeramTec ref.no.

30 3531 44

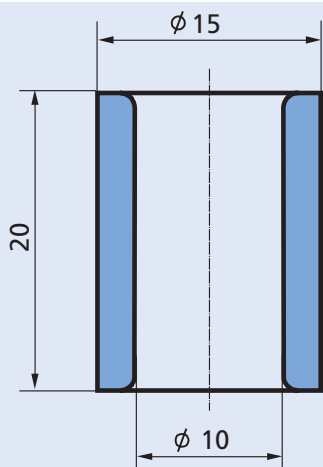

M 2:1

CeramTec Best. Nr.
CeramTec ref.no.

30 3531 68

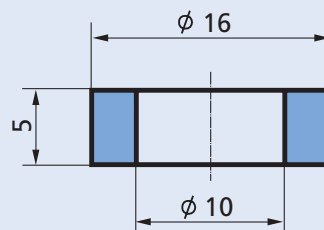

M 2:1

CeramTec Best. Nr.
CeramTec ref.no.

30 3531 37

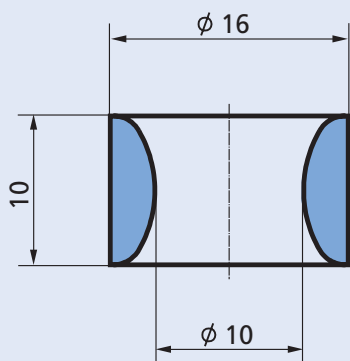

M 2:1

CeramTec Best. Nr.
CeramTec ref.no.

30 3202 00

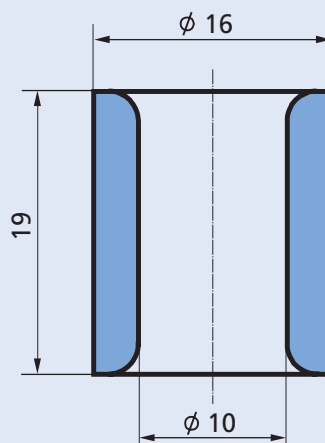

M 2:1

CeramTec Best. Nr.
CeramTec ref.no.

30 3531 43

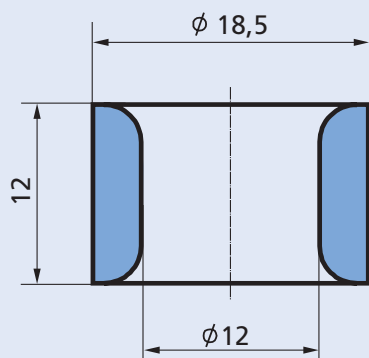

M 2:1

CeramTec Best. Nr.
CeramTec ref.no.

30 0139 00

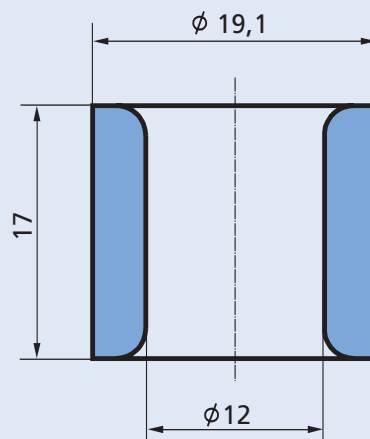

M 2:1

CeramTec Best. Nr.
CeramTec ref.no.

30 3531 42

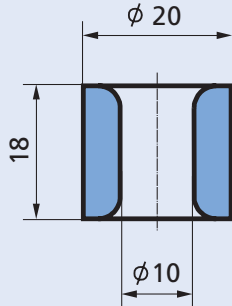

M 1:1

CeramTec Best. Nr.
CeramTec ref.no.

30 3114 00

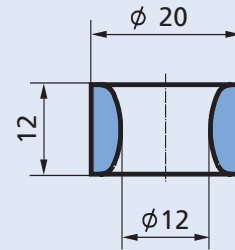

M 1:1

CeramTec Best. Nr.
CeramTec ref.no.

30 3203 00

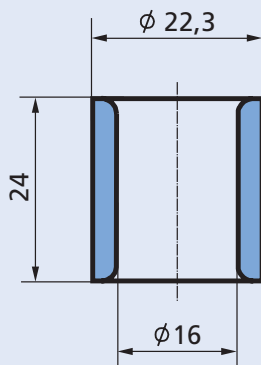

M 1:1

CeramTec Best. Nr.
CeramTec ref.no.

30 3531 41

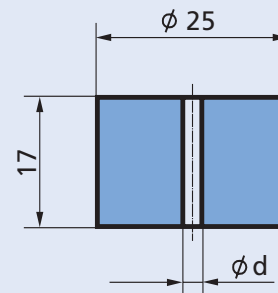

M 1:1

CeramTec Best. Nr.
CeramTec ref.no.

d = 1,5 30 3531 50
d = 2,5 30 3531 51

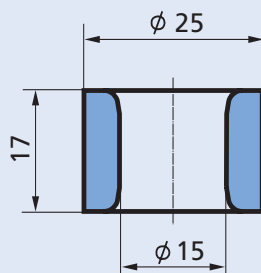

M 1:1

CeramTec Best. Nr.
CeramTec ref.no.

30 3160 00

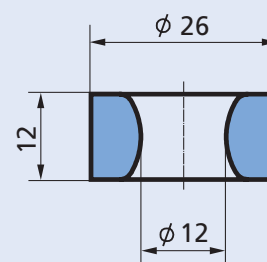

M 1:1

CeramTec Best. Nr.
CeramTec ref.no.

30 3530 10

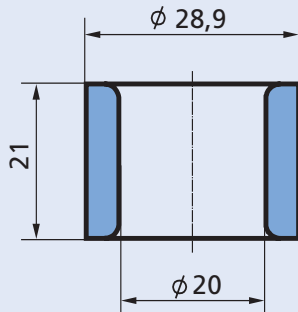

M 1:1

CeramTec Best. Nr.
CeramTec ref.no.

30 3531 40

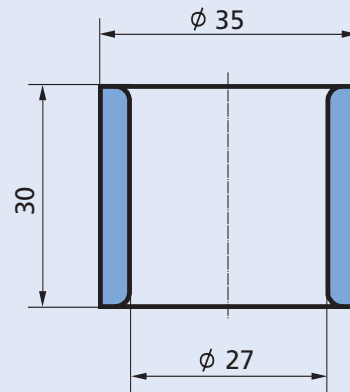

M 1:1

CeramTec Best. Nr.
CeramTec ref.no.

30 3531 39

Konische Ösen
Tapered eyelets

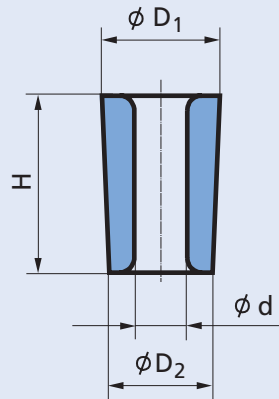

CeramTec Best. Nr. CeramTec ref.no.	Abmessungen (mm) Dimensions				Seite Page
	D ₁	D ₂	d	H	
30 0169 00	4,8	4,0	2,0	2,7	34
30 3337 01	6,0	5,5	1,5	5,0	34
30 3531 52	7,5	7,2	4,0	4,0	34
30 3531 77	8,0	8,0	3,2	10,2	34
30 0173 00	8,0	7,0	3,6	12,0	34
30 0176 00	11,0	9,2	4,9	15,0	34
30 0166 00	13,0	11,8	6,0	11,8	35
30 0177 00	13,0	11,3	6,0	17,0	35
30 3488 01	13,6	9,6	3,8 / 8,2	22,0	35
30 3180 00	14,8	13,0	7,0	18,0	35
30 3466 00	15,0	11,4	6,0	11,0	35
30 3122 00	16,0	14,3	7,6	17,7	35
30 3177 00	20,0	19,1	12,0	18,0	36
30 3178 00	24,0	22,8	16,0	25,0	36

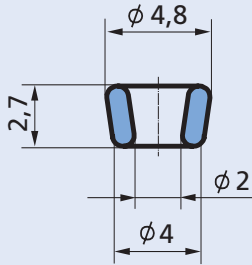

M 3:1

CeramTec Best. Nr.
CeramTec ref.no.

30 0169 00

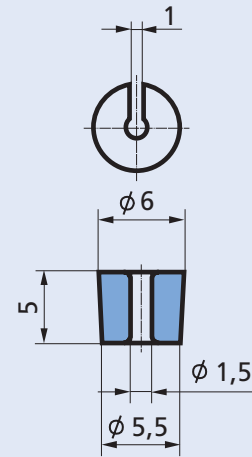

M 2:1

CeramTec Best. Nr.
CeramTec ref.no.

30 3337 01

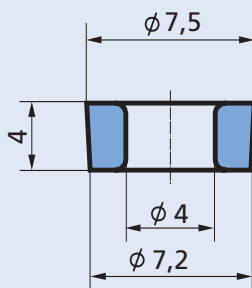

M 3:1

CeramTec Best. Nr.
CeramTec ref.no.

30 3531 52

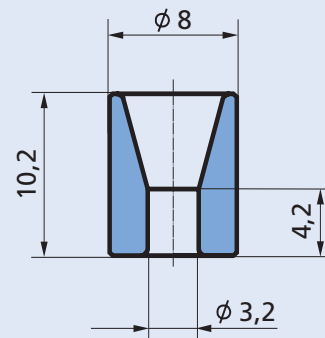

M 2:1

CeramTec Best. Nr.
CeramTec ref.no.

30 3531 77

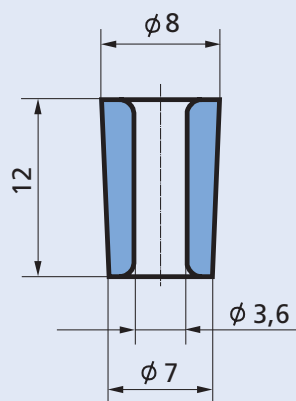

M 2:1

CeramTec Best. Nr.
CeramTec ref.no.

30 0173 00

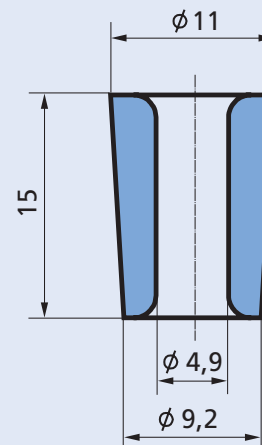

M 2:1

CeramTec Best. Nr.
CeramTec ref.no.

30 0176 00

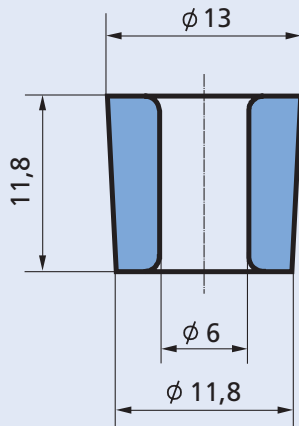

M 2:1

CeramTec Best. Nr.
CeramTec ref.no.

30 0166 00

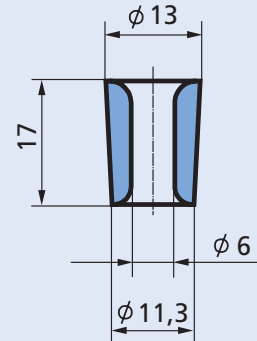

M 1:1

CeramTec Best. Nr.
CeramTec ref.no.

30 0177 00

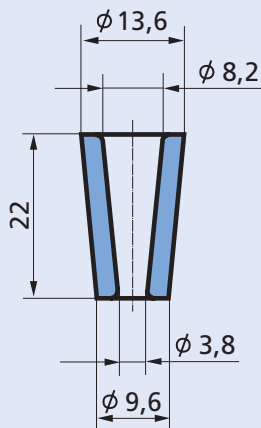

M 1:1

CeramTec Best. Nr.
CeramTec ref.no.

30 3488 01

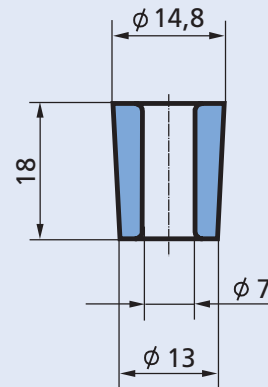

M 1:1

CeramTec Best. Nr.
CeramTec ref.no.

30 3180 00

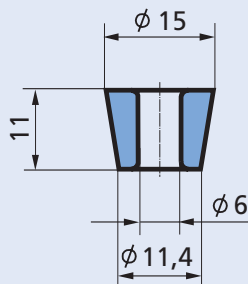

M 1:1

CeramTec Best. Nr.
CeramTec ref.no.

30 3466 00

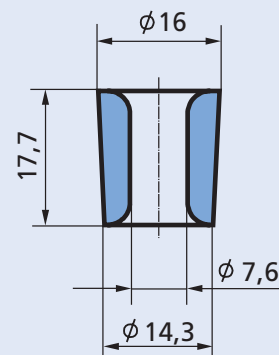

M 1:1

CeramTec Best. Nr.
CeramTec ref.no.

30 3122 00

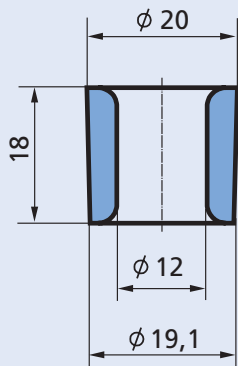

M 1:1

CeramTec Best. Nr.
CeramTec ref.no.

30 3177 00

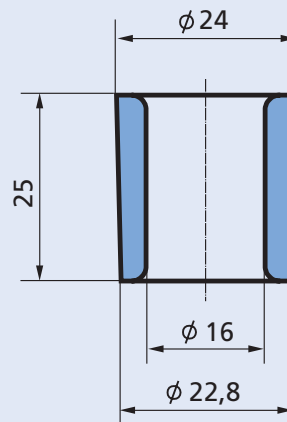

M 1:1

CeramTec Best. Nr.
CeramTec ref.no.

30 3178 00

Rillenösen
Annular eyelets with groove

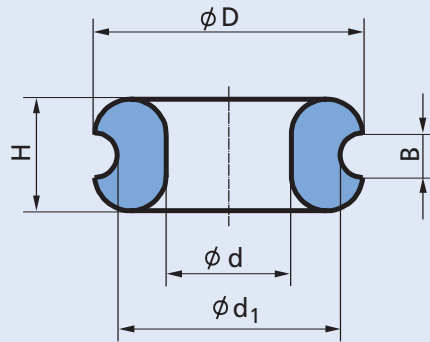

CeramTec Best. Nr. CeramTec ref.no.	Abmessungen (mm) Dimensions					Seite Page
	D	d	d ₁	B	H	
30 0159 01	8,3	2,2	7,6	3,0	3,9	38
30 0138 00	5,5	3,0	4,5	1,0	2,5	38
30 0158 00	8,5	3,2	6,4	2,0	4,4	38
30 0107 00	8,5	4,2	7,0	4,0	7,0	38
30 0112 00	11,4	4,5	9,0	-	4,8	38
30 0110 02	11,4	4,5	9,0	-	4,8	39
30 0156 00	12,0	5,6	10,0	2,0	5,0	39
30 0168 00	18,0	6,0	12,0	3,6	9,0	39
30 3526 01	11,0	7,0	9,0	6,0	10,0	38
30 3531 30	13,0	7,0	10,5	2,5	6,0	39
30 3531 76	14,0	7,2	10,9	2,0	6,0	39
30 3531 00	13,3	8,5	12,3	6,0	10,0	39
30 0127 00	18,7	10,3	14,6	3,0	5,8	40
30 5821 00	33,0	21,0	30,0	3,5	7,8	40

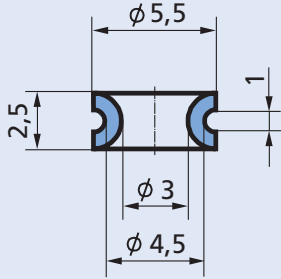

M 3:1

CeramTec Best. Nr.
CeramTec ref.no.

30 0138 00

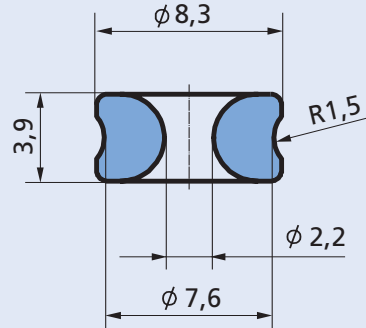

M 3:1

CeramTec Best. Nr.
CeramTec ref.no.

30 0159 01

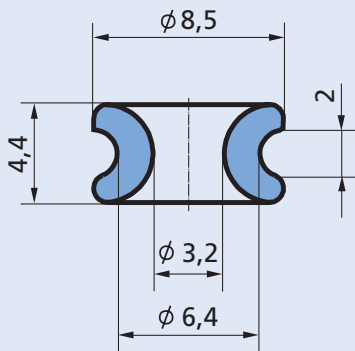

M 3:1

CeramTec Best. Nr.
CeramTec ref.no.

30 0158 00

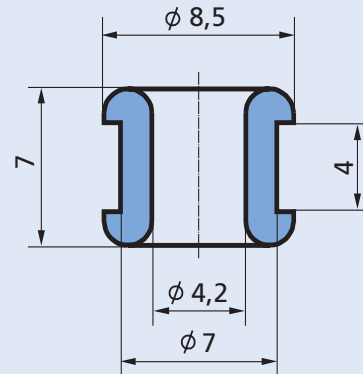

M 3:1

CeramTec Best. Nr.
CeramTec ref.no.

30 0107 00

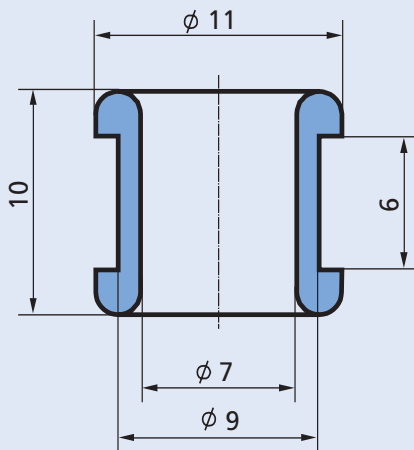

M 3:1

CeramTec Best. Nr.
CeramTec ref.no.

30 3526 01

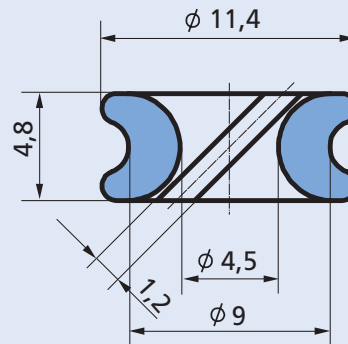

M 3:1

CeramTec Best. Nr.
CeramTec ref.no.

30 0112 00

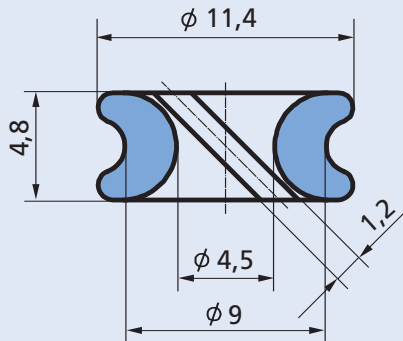

M 3:1

CeramTec Best. Nr.
CeramTec ref.no.

30 0110 02

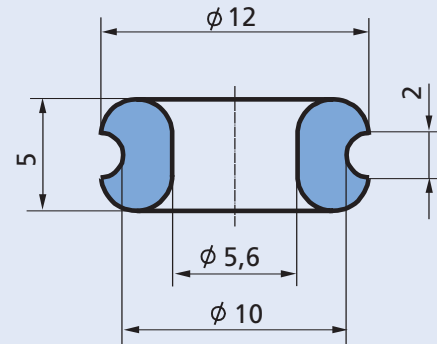

M 3:1

CeramTec Best. Nr.
CeramTec ref.no.

30 0156 00

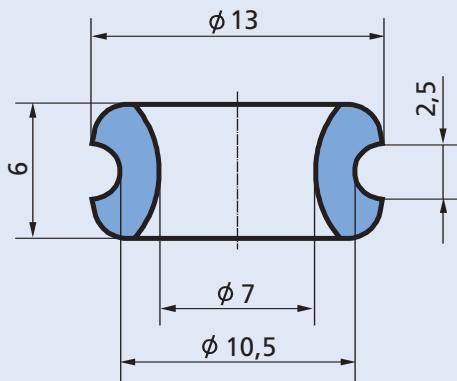

M 3:1

CeramTec Best. Nr.
CeramTec ref.no.

30 3531 30

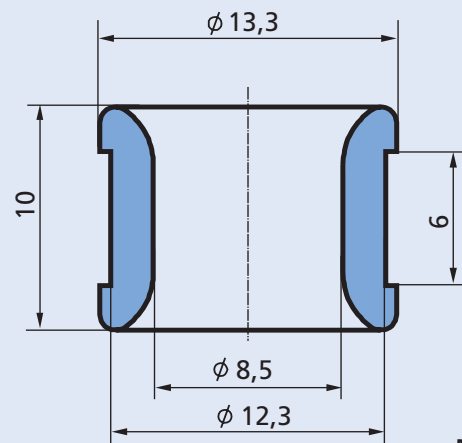

M 3:1

CeramTec Best. Nr.
CeramTec ref.no.

30 3531 00

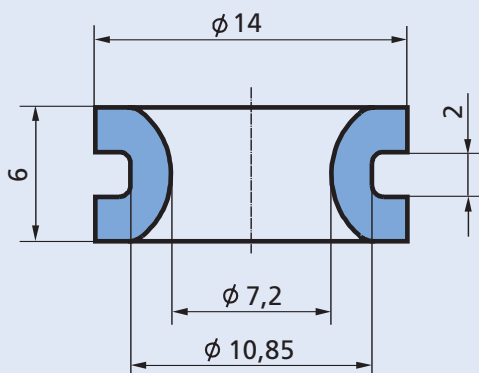

M 3:1

CeramTec Best. Nr.
CeramTec ref.no.

30 3531 76

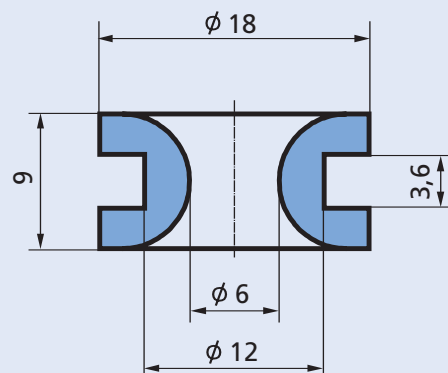

M 2:1

CeramTec Best. Nr.
CeramTec ref.no.

30 0168 00

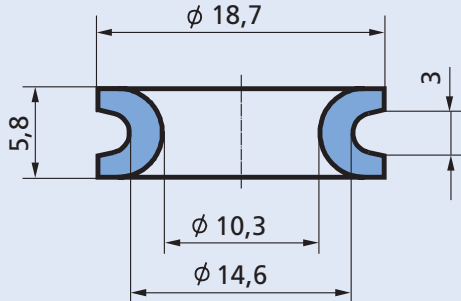

M 2:1

CeramTec Best. Nr.
CeramTec ref.no.

30 0127 00

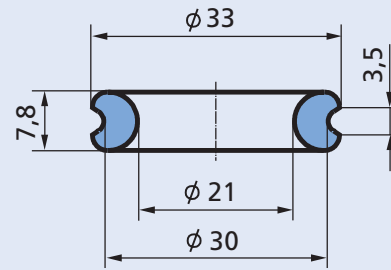

M 1:1

CeramTec Best. Nr.
CeramTec ref.no.

30 5821 00

Spezialösen
Special eyelets

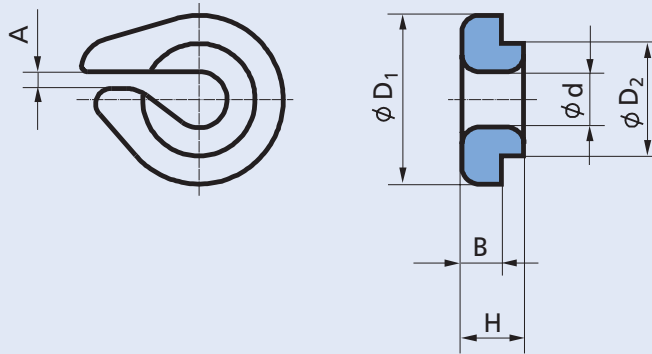

CeramTec Best. Nr. CeramTec ref.no.	Abmessungen (mm) Dimensions						Seite Page
	D ₁	D ₂	d	A	B	H	
30 3531 32	12,0	10,0	1,0	-	2,0	7,0	43
30 3250 00	8,7	5,4	2,4	1,4	0,8	3,2	42
30 3364 01	12,0	9,0	3,0	-	1,6	5,4	42
30 5915 01	30,0	20,0	3,0	-	5,0	30,0	43
30 3531 77	8,0	8,0	3,2	-	-	10,2	43
30 5915 00	30,0	20,0	3,3	-	5,0	29,5	43
30 6327 01	12,8 / 14,5	8,8	3,5 / 5,5	-	4,5	7,0	44
30 0112 00	7,0	7,0	3,6	2,7	-	5,0	42
30 3365 00	11,0	9,0	4,0	-	-	5,9	42
30 0124 00	12,5	8,5	4,0	-	-	5,0	44
30 3279 02	15,0	10,0	5,0	1,5	2,0	18,0	42
30 6385 02	10,0	-	6,0	-	-	19,0	44
30 3531 69	18,0	18,0	5 / 9,4	-	-	15,0	42
30 3526 02	10,8	-	-	6,5	2,0	10,0	45
30 3526 00	11,0	-	-	7,0	2,0	10,0	45
30 3526 03	13,3	-	-	8,5	2,0	10,0	45
30 3531 11	28,0	-	-	10,0	3,5	21,0	45

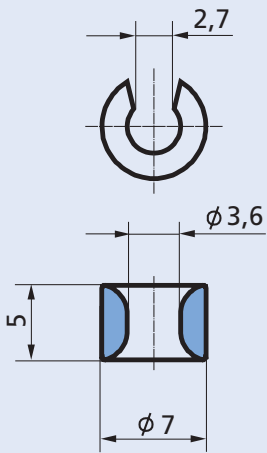

M 2:1

CeramTec Best. Nr.
CeramTec ref.no.

30 0112 00

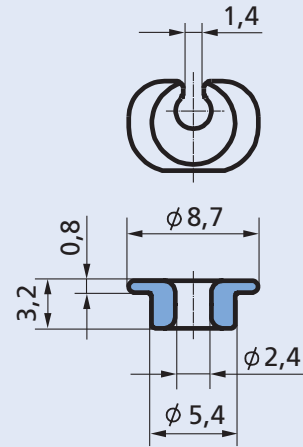

M 2:1

CeramTec Best. Nr.
CeramTec ref.no.

30 3250 00

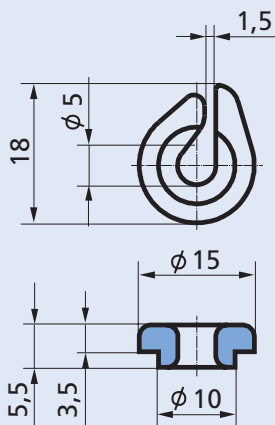

M 1:1

CeramTec Best. Nr.
CeramTec ref.no.

30 3279 02

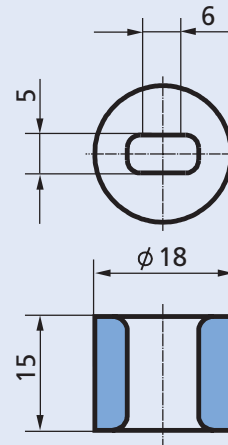

M 1:1

CeramTec Best. Nr.
CeramTec ref.no.

30 3531 69

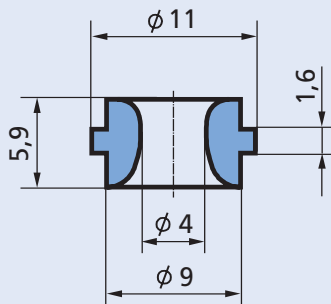

M 2:1

CeramTec Best. Nr.
CeramTec ref.no.

30 3365 00

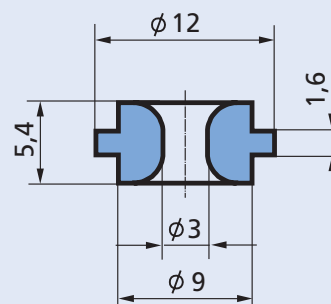

M 2:1

CeramTec Best. Nr.
CeramTec ref.no.

30 3364 01

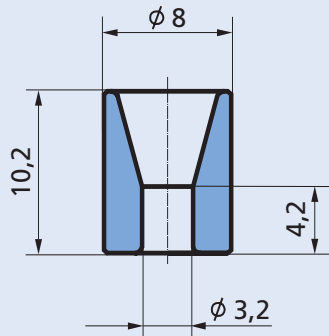

M 2:1

CeramTec Best. Nr.
CeramTec ref.no.

30 3531 77

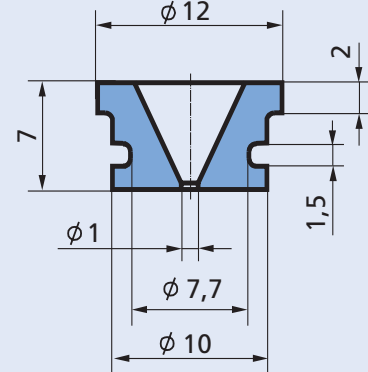

M 2:1

CeramTec Best. Nr.
CeramTec ref.no.

30 3531 32

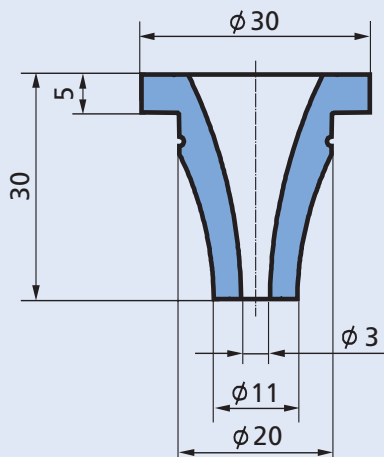

M 1:1

CeramTec Best. Nr.
CeramTec ref.no.

30 5915 01

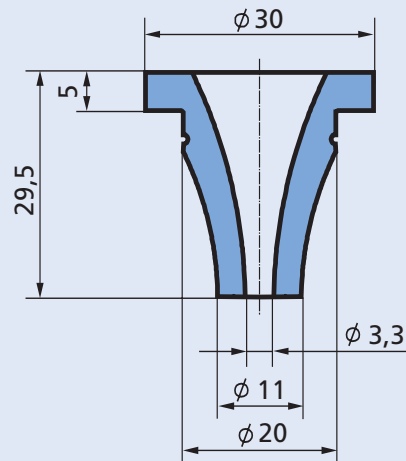

M 1:1

CeramTec Best. Nr.
CeramTec ref.no.

30 5915 00

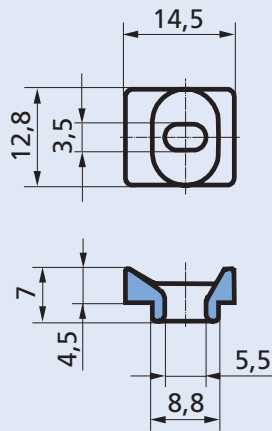

M 1:1

CeramTec Best. Nr.
CeramTec ref.no.

30 6327 01

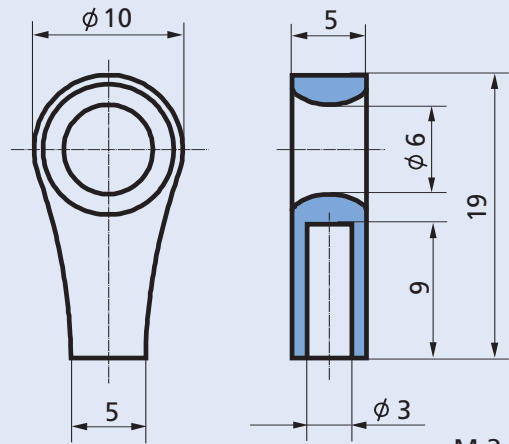

M 2:1

CeramTec Best. Nr.
CeramTec ref.no.

30 6385 02

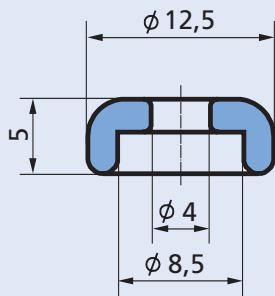

M 2:1

CeramTec Best. Nr.
CeramTec ref.no.

30 0124 00

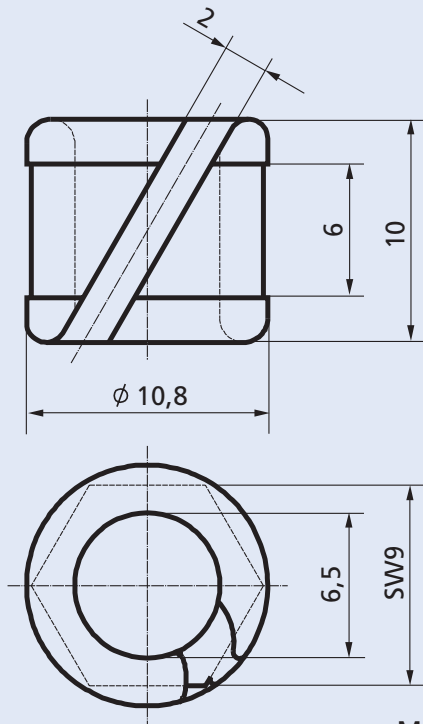

M 3:1

CeramTec Best. Nr.
CeramTec ref.no.

30 3526 02

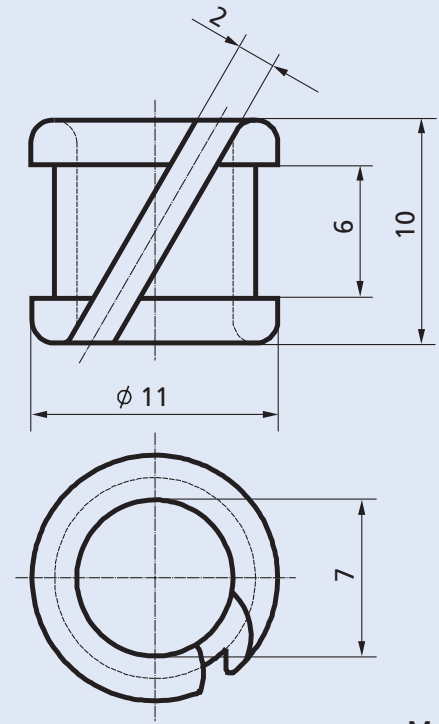

M 3:1

CeramTec Best. Nr.
CeramTec ref.no.

30 3526 00

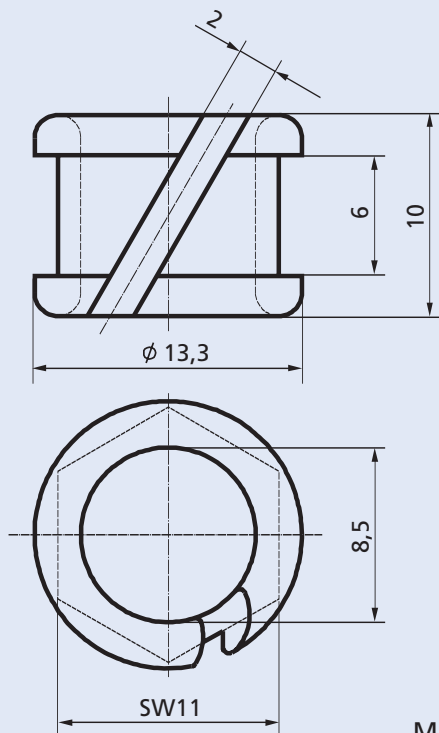

M 3:1

CeramTec Best. Nr.
CeramTec ref.no.

30 3526 03

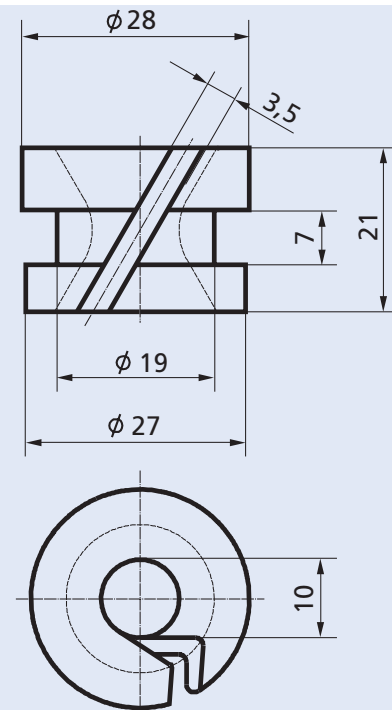

M 1:1

CeramTec Best. Nr.
CeramTec ref.no.

30 3531 11

