

N-Series

Addressable Rocker Switches

[PRODUCT WEBPAGE](#)

request sample, configure part



The N-Series produces up to 144 individual switch IDs by using a resistive ladder circuit. Different switch IDs are achieved by changing the resistor values tied to individual loads, which can then be assigned to the specific functions that the switch is controlling.

1	.4	28	IP67 Sealing
Pole	Amps	VDC Max	Above-Panel

Typical Applications

• On/Off-Highway • Construction • Agriculture • Marine

Tech Specs

Electrical

Contact Rating	.4VA @ 28VDC (MAX)
Dielectric Strength	1250 Volts RMS between pole to pole 3750 Volts RMS between live parts and accessible surfaces
Insulation Resistance	50 Megaohms
Contact Bounce	20 milliseconds max.
Contact	gold plated
Terminals	Brass or copper/silver plate 3/16" (4.76mm) Quick Connect terminations standard.

Physical

Lighted	Incandescent - rated 10,000 hours LED - rated 100,000 hours 1/2 life (LED is internally ballasted for voltages to 24VDC)
Seals	Rocker, base & bracket are sealed
Base	Nylon 66 GF rated to 85°C with a flammability rating of 94V0.
Rocker and Paddle	Nylon 66 Reinforced, rated to 105°C
Laser Etched Rocker	Polycarbonate rated at 100°C.
Lens	Polycarbonate rated at 100°C. Front snap-in.
Connector	Nylon 66 rated at 85°C. Polarized.
Bracket	Nylon Zytel

Actuator Travel (Angular Displacement)

2 position	26°
3 position	13° from center

Environmental

Environmental	IP67, for above-panel components of actual switch only.
Operating Temp.	-40°C to +85°C
Vibration	Per SAE J1399 "electronic Tachometer Specification" for Class II truck and bus applications. Test Criteria: No change in resistance and no evidence of physical damage.
Salt Spray	Exposure to 95% water, 5% NCl fog solution at 95 degrees F according to ASTM B 117-90 "Standard Method of Salt Spray (fog) Testing". Test Criteria: No visual evidence of corrosion or external physical damage.
Humidity	Samples were exposed to selected temperature profile, while maintaining 90% +- 5% relative humidity for 30 cycles. Test Criteria: No evidence of external physical deterioration.

Mounting Specifications

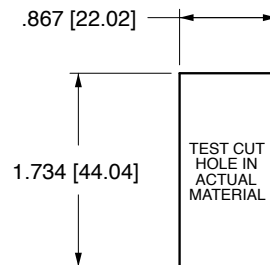

MOUNTING HOLE

Panel Thickness Range

Acceptable Panel Thickness
.030 to .156 (.76mm to 3.96mm)
Recommended:
.030, .062, .093, .125 and .156

Ordering Scheme

Sample Part Number

N 4 1 2 1 A N H 1 - 1 1 2 46 - 1 EK

Selection 1 2 3 4 5 6 7 8 9 10 11 12 13 14 15

1. SERIES

N

2. CIRCUIT 2

Terminal Orientation

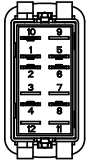

() - momentary

Position:	1	2	3
STANDARD	2 & 4	Connected Terminals	1 & 2
4	(ON)	NONE	ON
5	(ON)	NONE	ON
6	(ON)	ON	ON
7	(ON)	ON	ON
8	(ON)	ON	(ON)

3. R1 RESISTIVE IDENTIFICATION

1	1020	7	3570
2	1300	8	4320
3	1620	A	5230
4	2000	B	6340
5	2430	C	7870
6	2940	D	10000

4. R2 RESISTIVE IDENTIFICATION

1	1020	7	3570
2	1300	8	4320
3	1620	A	5230
4	2000	B	6340
5	2430	C	7870
6	2940	D	10000

5. RESISTOR CONSTANTS (INDICATES SWITCH STATE)

	R3	R4	R5
1	1300	10000	5230
2	825	6650	3830

6. ILLUMINATION

Lamp #1: above terminals 9 & 10 end of switch; Lamp #2 above terminals 11 & 12 end of switch. Positive (+) and negative (-) symbols apply to LED lamps only.

S	Lamps	Illumination Type	Lamp wired to Terminals
A	#1	Standard	10+ 12-
	#2	Standard	11+ 9-
B	#1 & 2	Special Parallel	11+ 9-
C	#1 & 2	Special Parallel	10+ 9-
1	#1	Independent	10+ 9-
2	#2	Independent	12+ 11-
3	#1	Independent	10+ 9-
	#2	Independent	12+ 9-
4	#1	Independent	10+ 9-
	#2	Independent	12+ 11-

7,8. LAMP (SAME CODING FOR BOTH SELECTIONS)

Selection 7: above terminals 10 & 9; Selection 8: above terminals 12 & 11

No lamp 0
LED* Red Amber Green
12VDC C N H

* Consult factory for "daylight bright", blue/green and white LED options. Typical current draw for LED is 20ma.

9. BRACKET COLOR 1

	Black	White	Gray	Red
Standard Bracket	6	7	8	9
Rockerguard at Lamp 1	L	B	C	D
Rockerguard at Lamp 2	E	F	G	H

10. ACTUATOR STYLE AND COLOR

	Black	White	Gray	Red	Laser Etched
Rocker	A	B	C	D	1
Paddle	J	N	K	M	

11. & 12. LENS STYLE AND COLOR

Lens color for LEDs must be clear, white, or match color of LED.

0	No Actuator			Z - No Lens		
	Clear	White	Amber	Green	Red	Blue
1	-	B	G	M	T	Large Transparent
-	7	C	H	N	U	Large Translucent
3	-	D	J	P	V	Bar Transparent
-	9	E	K	R	W	Bar Translucent
5	A	-	-	-	-	Laser Etch background color

13. LEGEND ORIENTATION

00 No legend

For standard legends, see "Standard Legend Codes" page. For additional legends, please consult factory

14. LEGEND ORIENTATION

- 0 No legend (used with codes 11-18 in selection 12)
- 1 Orientation 1 - vertical, lamp 1 on top
- 2 Orientation 2 - horizontal, lamp 1 on right
- 3 Orientation 3 - vertical, lamp 1 on bottom
- 4 Orientation 4 - vertical, lamp 1 on left

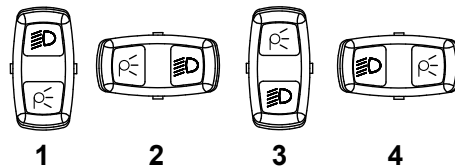

15. ACTUATOR LENS LEGEND

00 No legend

For standard legends, see "Standard Legend Codes" page. For additional legends, please consult factory

Notes:

- 1 Custom colors are available. Consult factory.
- 2 Switch supplied with .187 tab terminals.

[Configure Complete Part Number >](#)

[Browse Standard Parts >](#)

Dimensional Specs

inches [millimeters]

LASER ETCHED ACTUATOR

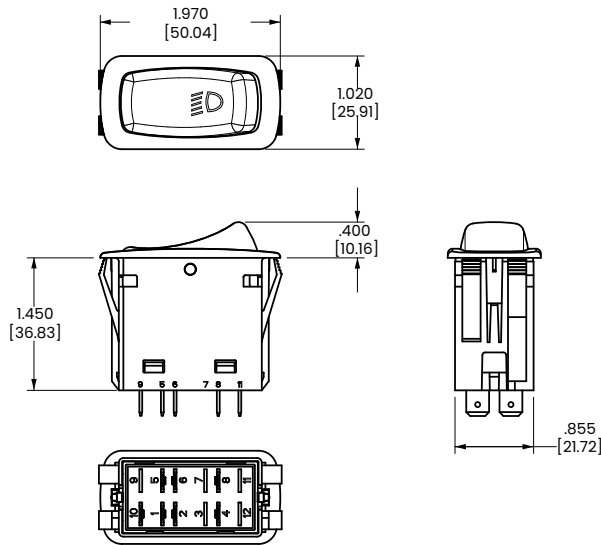

ROCKER GUARD

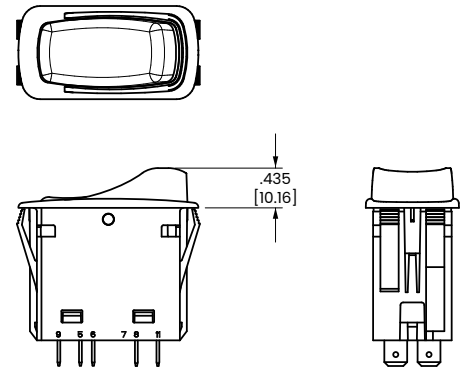

LARGE LENS AND PADDLE ACTUATOR

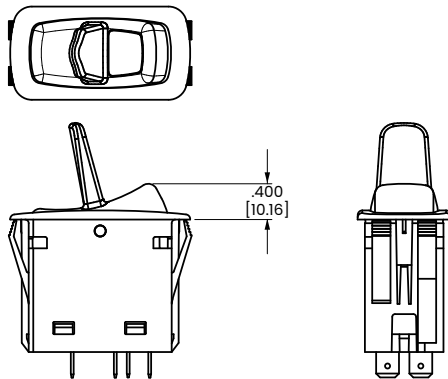

BARS LENS AND CONNECTOR

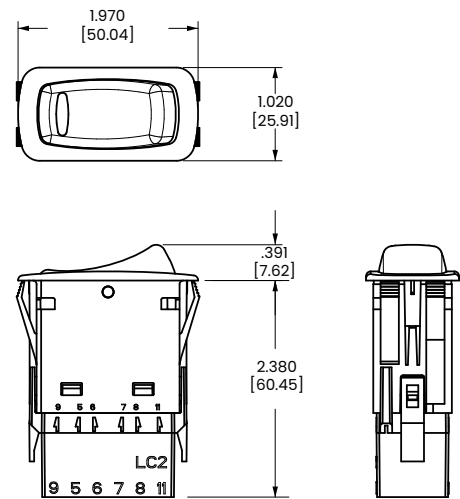

ACCESSORY

LC2-01 BLACK .187 TAB CONNECTOR (PACKARD 480-SERIES)

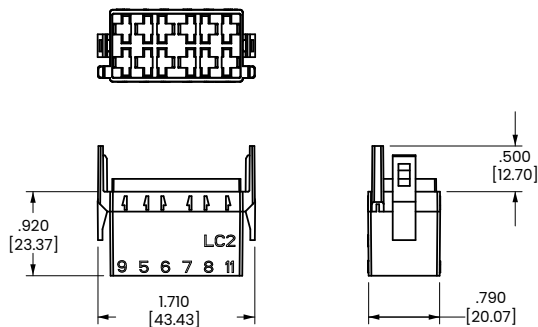

ACCESSORY

LH1 REMOVABLE HOLE PLUG WITH NON-SERRATED WINGS
LH2 HOLE PLUG WITH SERRATED WINGS

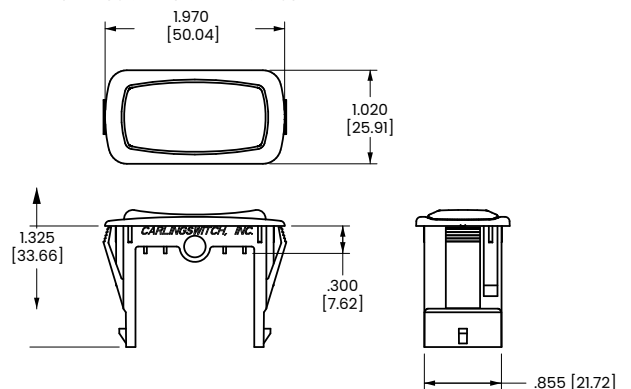

Diagrams

Circuit Diagrams:

CIRCUIT CODE	SCHEMATIC
4	
5	
6	
7	
8	

INTERNAL
CIRCUIT
BOARD
(TYPICAL)

Lamp Circuit Diagrams:

ILLUM. CODE	SCHEMATIC
A	
B	
C	
1	
2	
3	
4	

Authorized Sales Representatives and Distributors

Click on a region of the map below to find your local representatives and distributors or visit www.carlingtech.com/findarep.



About Carling

Founded in 1920, Carling Technologies is a leading manufacturer of electrical and electronic switches and assemblies, circuit breakers, electronic controls, power distribution units, and multiplexed power distribution systems. With six ISO9001 and IATF16949 registered manufacturing facilities and technical sales offices worldwide, Carling Technologies Sales, Service and Engineering teams do much more than manufacture electrical components, they engineer powerful solutions! To learn more about Carling please visit www.carlingtech.com/company-profile.

To view all of Carling's environmental, quality, health & safety certifications please visit www.carlingtech.com/environmental-certifications.

© Carling Technologies, Inc.

6. Carling is a registered trademark of Carling Technologies, Inc. in the U.S. and other countries.