



KOMPATTO 221

**TECHNICAL DATA
SPÉCIFICATIONS PRODUIT
ESPECIFICACION TÉCNICA**

KOMPATTO 221

The KOMPATTO 221 Screener is a small yet robust machine designed for recycling, composting, topsoil, landscaping, and contract building industries. Its compact size, quick set-up times, ease of transport and ease of operation makes the KOMPATTO 221 the ideal solution for small scale operations.

La KOMPATTO 221 est une machine petite mais robuste conçue pour les industries du recyclage, du compostage, de la terre végétale, de l'aménagement paysager et de la construction contractuelle. Sa taille compacte, ses temps d'installation rapides, sa facilité de transport et sa facilité d'utilisation font du KOMPATTO 221 la solution idéale pour les opérations à petite échelle.

La KOMPATTO 221 es una criba compacta pero también robusta, diseñada para aplicaciones de reciclaje, compostaje, tierra vegetal, paisajismo y construcción. Su diseño compacto, y su fácil operación y transporte, convierte la criba KOMPATTO 221 en la herramienta ideal para operadores pequeños.

1. SCREEN BOX/CRIBLE/CRIBLA
2. FINE SIZE/TAPIS FINES/CINTA FINO
3. MID-SIZE/GRAIN MOYEN/CINTA MEDIO
4. POWER UNIT/MOTEUR/ACCIONAMIENTO
5. CONTROL/COMMANDE/CONTROL
6. TRACKS/CHENILLES/ORUGA





SCREENER



TECHNICAL DATA

SPÉCIFICATIONS PRODUIT

ESPECIFICACION TÉCNICA

SCREEN BOX
CRIBLE CAISSON
CRIBLA

2200X1100mm (10'X4')

OUTPUT POTENTIAL UP TO
PRODUCTION/RENDEMENT JUSQU'A'
PRODUCCION HASTA

80tph / 90 US tph



POWERUNIT

MOTEUR

ACCIONAMIENTO

Stage V: 18,5kW / 25Hp Diesel Engine

Tier 4Final: 18,5kW / 25Hp Diesel Engine

Stage 3A: 21,5kW / 28Hp Diesel Engine

WEIGHT

POIDS

PESO

3.300kgs (7.275lbs)

STANDARD MACHINE

GENERAL MACHINE

STANDARD

Remote control

Radio control

Remoto

OPTION

Long fine size

Punch plate – Mesh – Mesh Arpa

Longeur tapis fines

Plaque perforée – Mailles – Grille Losange

Largo cinta medio

Planchas perforadas – Mallas – Mallas Arpa



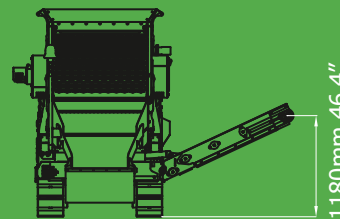
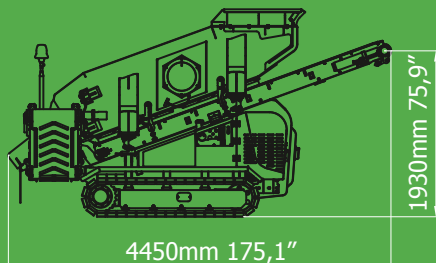
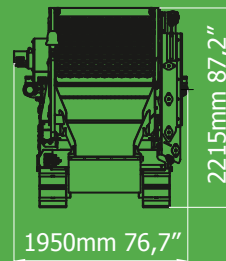
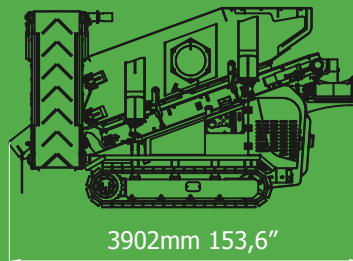
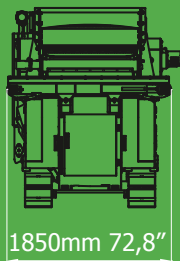
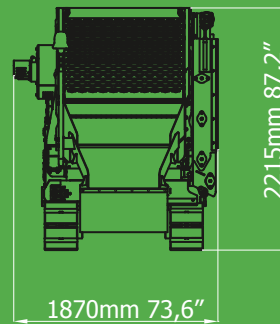
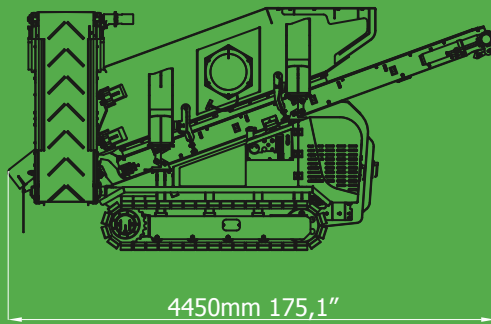

QUICK, EASY AND SAFE TRANSPORT
TRANSPORT RAPIDE, FACILE ET SÛR
TRANSPORTE RÀPIDO, FACIL Y ASEGURADO



DEALER

WWW.KOMPLET.IT
WWW.KOMPLETAMERICA.COM

