

DTC80 H160



GEAX

DRILLING EQUIPMENT

DTC80

HYDRAULIC-DRILLING RIG

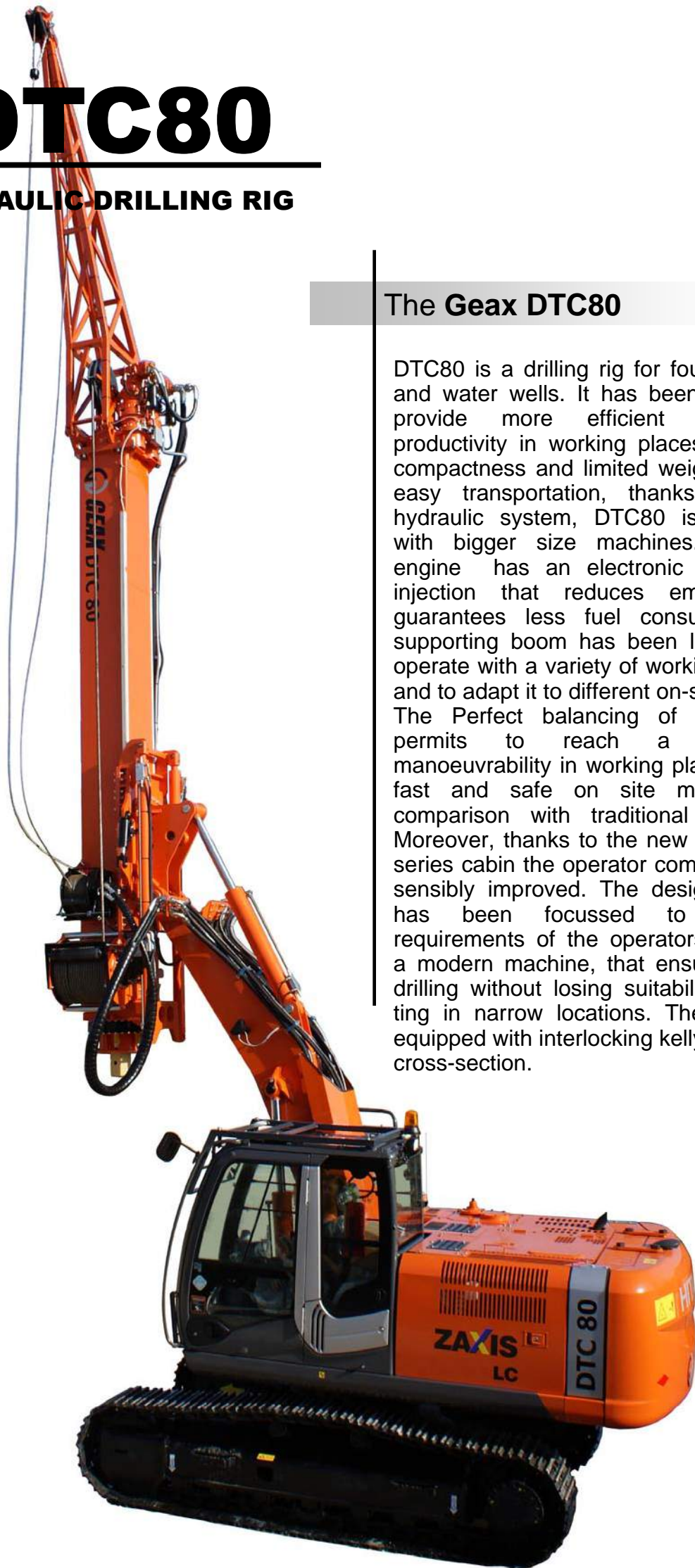

The Geax DTC80

DTC80 is a drilling rig for foundation piles and water wells. It has been designed to provide more efficient power and productivity in working places. Despite its compactness and limited weight that allow easy transportation, thanks to a new hydraulic system, DTC80 is comparable with bigger size machines. The Isuzu engine has an electronic common rail injection that reduces emissions and guarantees less fuel consumption. The supporting boom has been lengthened to operate with a variety of working conditions and to adapt it to different on-site situations. The Perfect balancing of the machine permits to reach a very high manoeuvrability in working places ensuring fast and safe on site movements in comparison with traditional equipments. Moreover, thanks to the new Hitachi 160-3 series cabin the operator comfort has been sensibly improved. The design of the rig has been focussed to meet the requirements of the operators, developing a modern machine, that ensures powerful drilling without losing suitability for operating in narrow locations. The machine is equipped with interlocking Kelly bar of round cross-section.

DTC80

HYDRAULIC DRILLING RIG

A new, solid and compact Mast

- high overall rigidity
- guided bars
- independent movement for the vertical alignment of the tower, saving initial set-up time
- rope paths which do not depend on the position of the tower, increasing reliability and helping to reduce initial set-up times
- the mast can easily be positioned to lower the machine's centre of gravity, allowing safe on-site manoeuvring
- the mast can be easily adjusted to the same height as the cabin
- the machine can be operated with a variety of tool axis distances to adapt it to different on-site situations
- the operator is given good visibility of the work area
- ease of use
- reduction of noise during bucket unloading

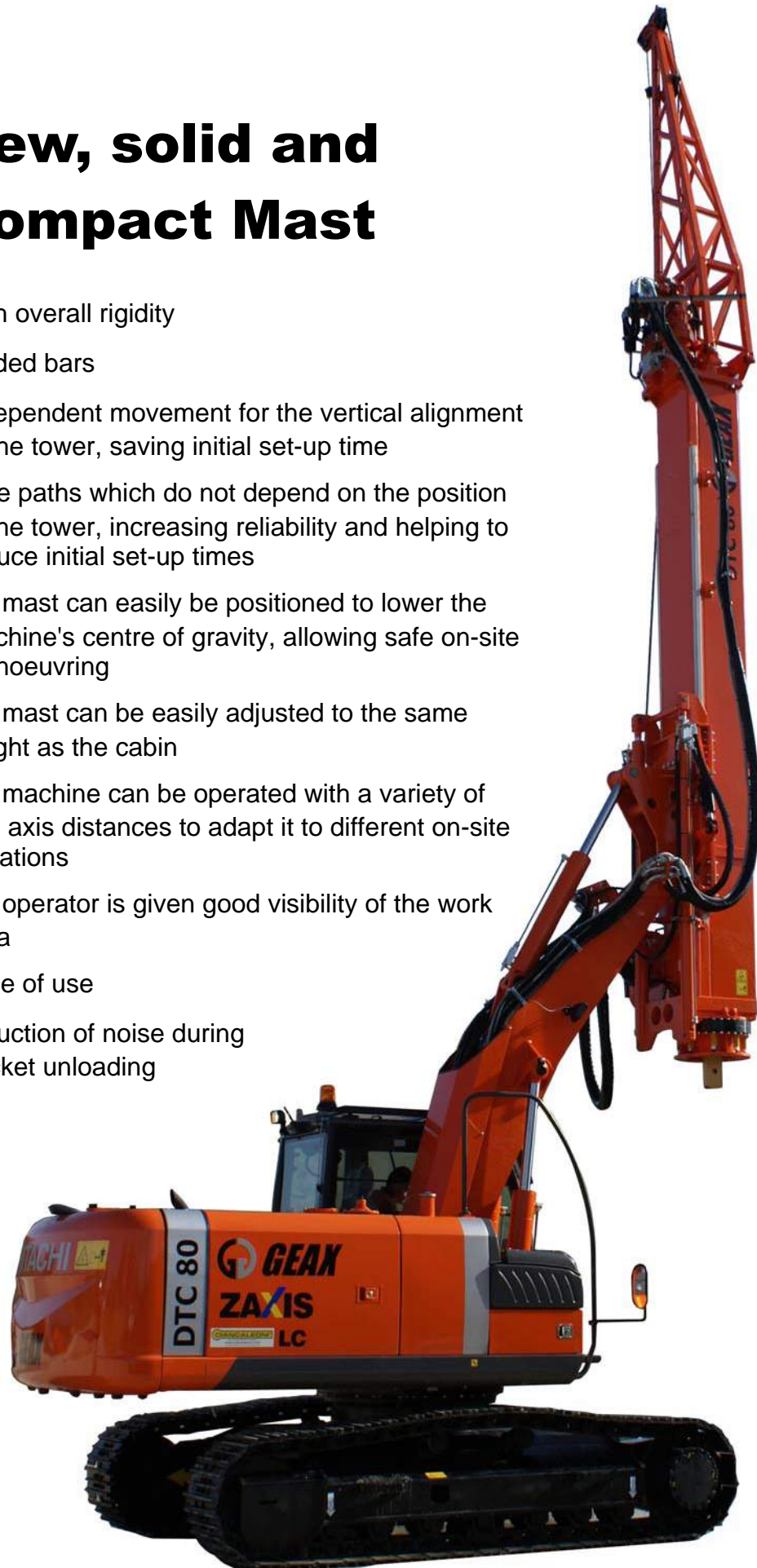

DTC80

HYDRAULIC DRILLING RIG

TECHNICAL FEATURES

Base	<i>Hitachi Zaxis 160 LC- 3</i>
Undercarriage length	3920 mm/ 12.86 ft
Undercarriage width	2490 mm / 8.17 ft
Shoe	500 mm / 1.64 ft
Engine type	ISUZU AI-4JJ1X
Engine power	90,2 kW / 123 hp
Mast	
Side rake	$\pm 5^\circ$
Stroke	2250 mm / 7.38 ft
Telescopic kelly bar	<i>circular interlocking</i>
Square connection	120 - 130 - 200 mm / 4.72 - 5.19 - 7.87 in
Max pile depth	31 m / 101.71 ft
Max pile diameter	1500 mm / 4.92 ft
Rotary	<i>Hydraulic</i>
Max nominal torque	8200 daNm / 60,483 lb _f ft
Drilling speed	10 - 40 rpm
Spin off speed	90 rpm
Winches	<i>Hydraulic</i>
Main winch line pull	12000 daN / 26,978 lb _f
Auxiliary winch line pull	3600 daN / 8,093 lb _f
Hydraulic system	
n.2 piston pumps	Flow : 2 X 191 l/min / 2 X 42 gal _(UK) /min
n.1 auxiliary pump	Flow : 33.6 l/min / 7.39 gal _(UK) /min
n.1 servocontrol pump	Flow : 33.6 l/min / 7.39 gal _(UK) /min
Weight	
mod.DTC80	24000 kg / 52,910 lb

Technical data are indicative and subject to change without notice.

DTC80

HYDRAULIC DRILLING RIG

Dimensions [mm] :

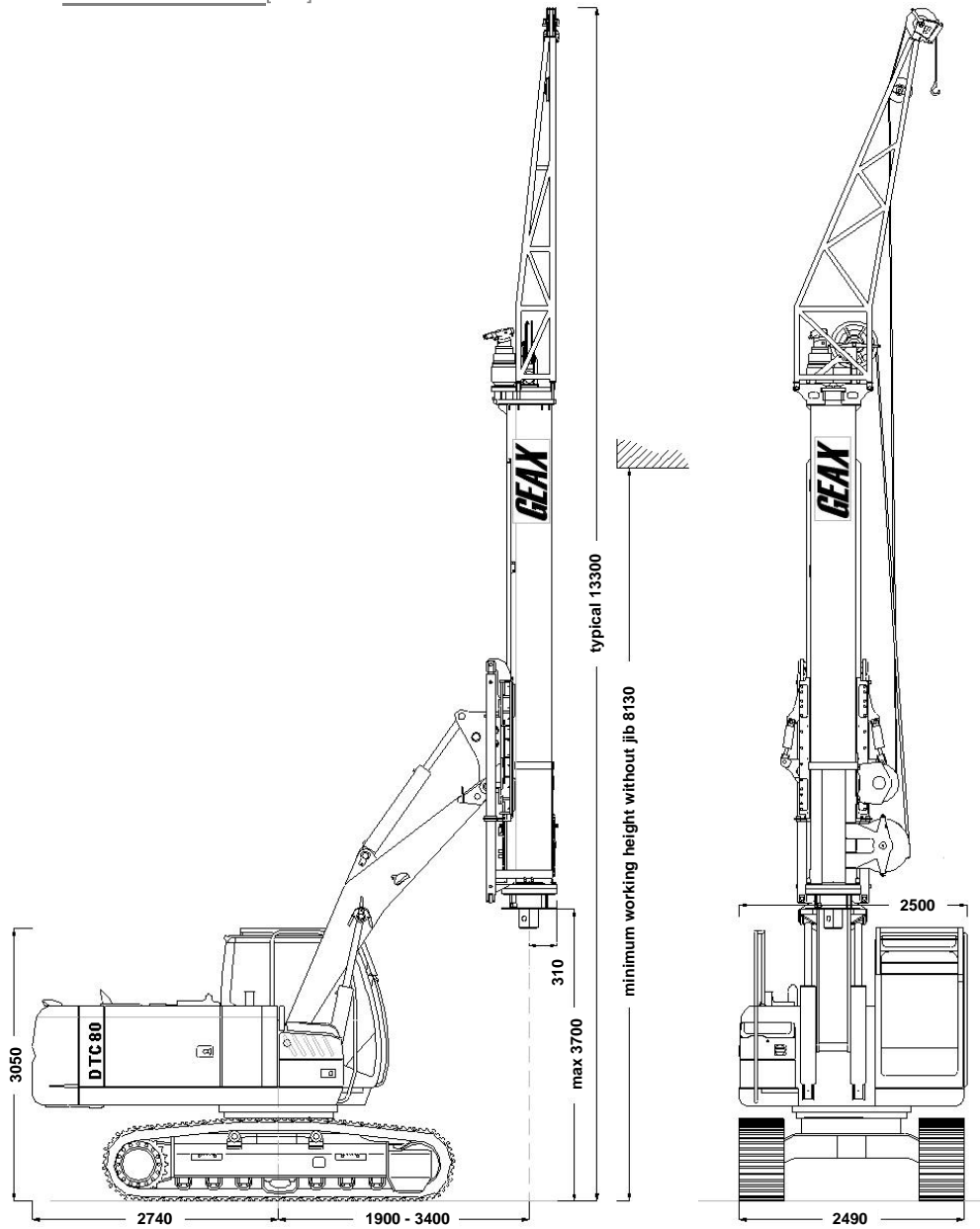

WORKING CONDITION

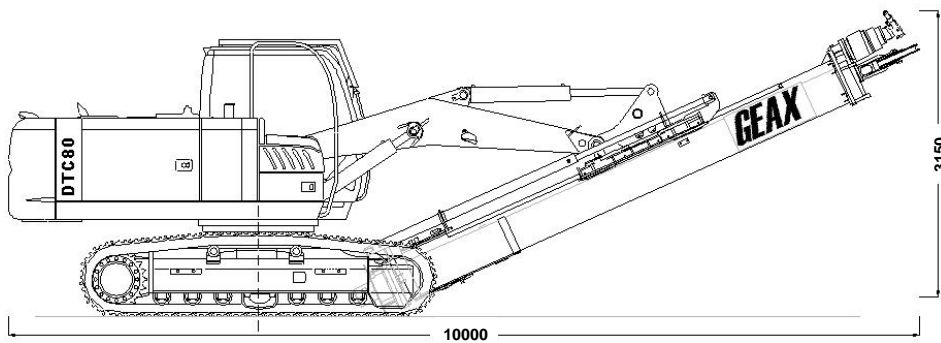

TRANSPORT CONDITION

DTC80

HYDRAULIC DRILLING RIG

Photogallery:



DTC80

HYDRAULIC DRILLING RIG



BORN TO WORK



GEAXs.r.l.

Drilling equipment
via Campoceraso n.11
60027 Osimo (AN) Italy
tel. +39 071 715199
<http://www.geax.it>
info@geax.it