



GEAX s.r.l.

DRILLING EQUIPMENT



DTC30E50

DTC30

HYDRAULIC DRILLING RIG

The machine's innovative concept is based on a monolithic steel structure where the telescopic bars rotate. The main advantages are :

- high overall rigidity;
- guided bars;
- vertical alignment of the mast achievable with simple and fast movements;
- passages of the steel-wire ropes not dependent on the inclination, the winches being integral with the mast;
- more positioning freedom thanks to the arm-structure;
- perfect visibility of the tool and the working area;
- easy maintenance thanks to the simple accessibility to the components;
- noise reduction during the spin off operation.

TECHNICAL FEATURES

Base	Eurocomach 500 ZT
Undercarriage length	2480 mm / 8.13 ft
Undercarriage width	1980 mm / 6.49 ft
Shoe	400 mm / 77.95 in
Engine type	KUBOTA V2403-M
Engine power	36,8 kW (50 HP)
Mast	Minimum working height without jib 4000 mm / 13.12 ft
Side rake	± 6,5°
Stroke	1200 mm / 3.94 ft
Telescopic kelly bar	Square / circular
Square connection	100 mm / 3.94 in
Max pile depth	12,5 - 15 m / 14 m interlocking bar 41- 49.2 ft / 45.9 ft
Max pile diameter	800 mm / 31.5 in
Rotary	Hydraulic
Max nominal torque	2700 daNm / 19,860 lb _f ft
Drilling speed	10 - 45 rpm
Spin off speed	45 rpm
Winches	Hydraulic
Main winch line pull	3500 daN / 7,868 lb _f
Auxiliary winch line pull	1100 daN / 2,473 lb _f
Hydraulic system	
n.2 piston pumps	flow: 2 X 60 l/min 2 X 13.2 gal _(UK) /min
n.1 auxiliary pump	flow: 45 l/min 9.9 gal _(UK) /min
Transport condition	
Length	5100 mm / 16.73 ft
Width	1980 mm / 6.49 ft
Height	2550 mm / 8.36 ft
Weight	9000 kg / 19,840 lb

DTC30

HYDRAULIC DRILLING RIG

WORKING CONDITION

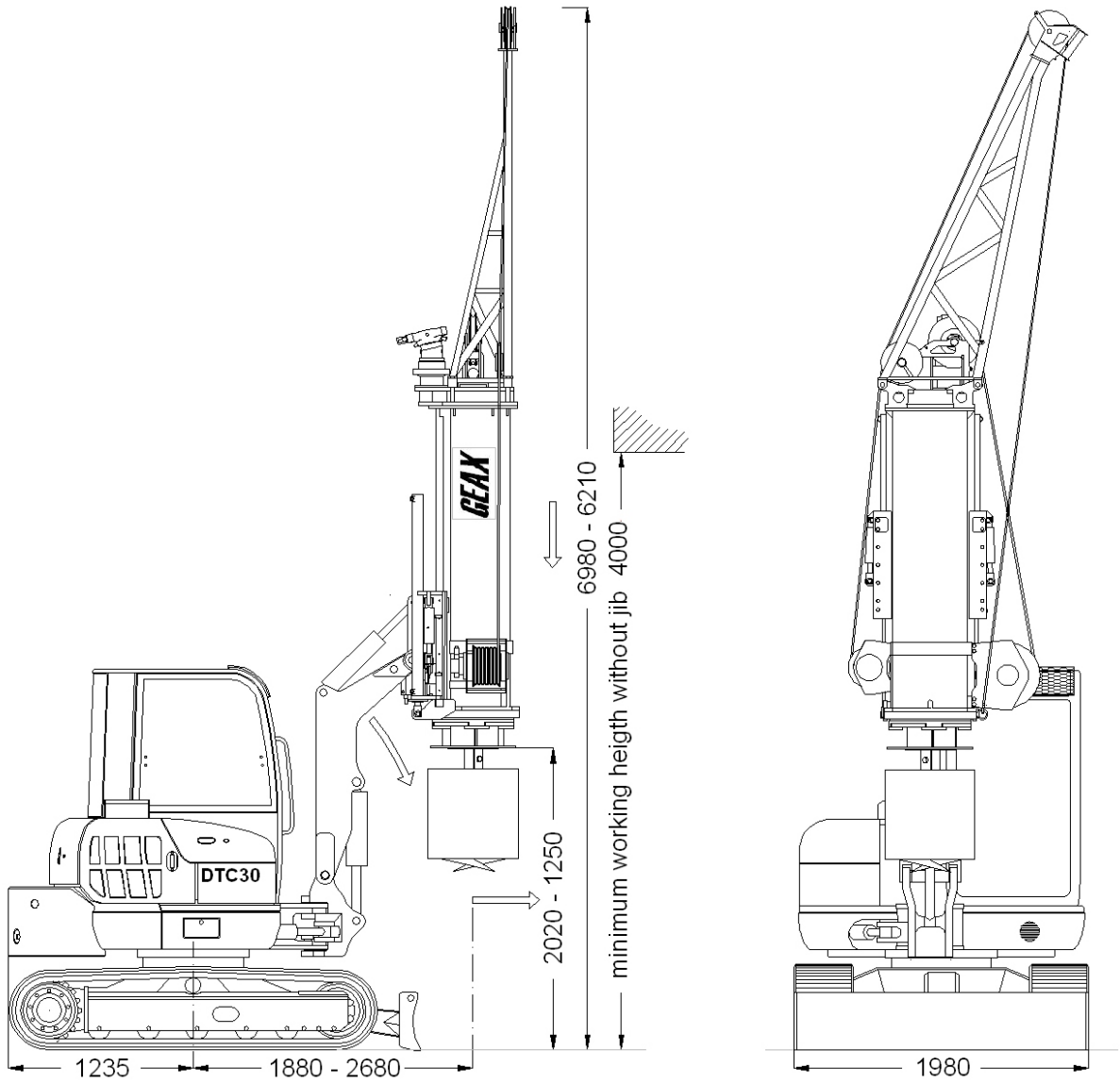

TRANSPORT CONDITION

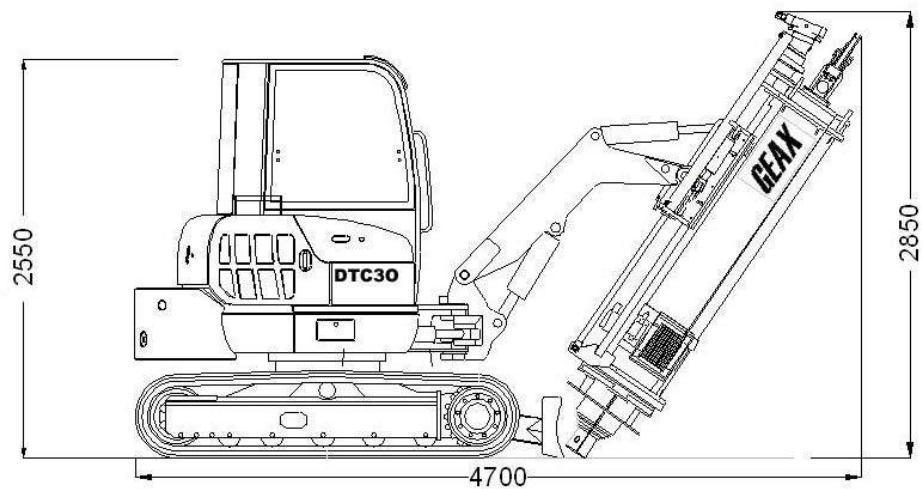



GEAX s.r.l.
Drilling equipment
via Campoceraso n.13
60027 Osimo (AN) Italy
tel/fax+39 071 715199
<http://www.geax.it>
info@geax.it

