



GB

- Extraction arm with internal bar system
- Arm balancing by gas springs and spring balancer
- Mountings for wall
- TGI can rotate free 360° for hose relief
- Hood standard without damper. Hood with damper is available against additional payment
- Length 2m (channel connection by nipple)
- Length 3-7m (channel connection by hose)
- Flow technical optimized hood
- Suitable for welding smoke, light dust and gases

D

- Absaugarm with Innen-Gestängesystem
- Arm-Auswuchten durch Gasfeder und Federbalancer
- Montagebeschlag für Wand
- TGI kann frei 360° drehen, um Schlauch zu entlasten
- Trichter Standard ohne Klappe. Trichter mit Klappe ist gegen Zulage erhältlich
- Länge 2m (Kanalanschluß durch Nippel)
- Länge 2-7m (Kanalanschluß durch Schlauch)
- Geeignet für Schweißrauch, leichten Staub und Gasen



Telescopic function

Based on double telescopic system inclusive spring balancer.

Extraction hood

Efficient high-performance extraction field is achieved with this hood type.

Quick coupling

Hood standard prepared for quick coupling for extension hose.

Space saving

Very space saving - can either hang completely horizontal or vertical against wall.

Teleskop-Funktion

Basiert auf doppeltes Teleskopsystem einschl. Federbalancer.

Absaugtrichter

Effizientes Hochleistungssaugfeld wird mit diesem Trichtertyp.

Schnellkupplung

Trichter Standard für Schnellkupplung für Verlängerungsschlauch vorbereitet.

Platzersparung

Sehr platzsparend - kann entweder ganz waagrecht oder senkrecht an der Wand ent-lang hängen.

Colour/Farbe: RAL 9005/9006 (structure/Struktur)

Extraction arm Punktabsaugarm

type
Typ

TGI

Diameter	Hose type*	Max. vacuum	Damper	See page
ø160-ø200mm	S1	1500 Pa	Yes	8.02

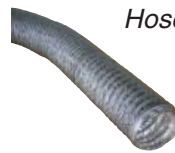

Hose type S1

* Special hoses are available

Type TGI 2000:

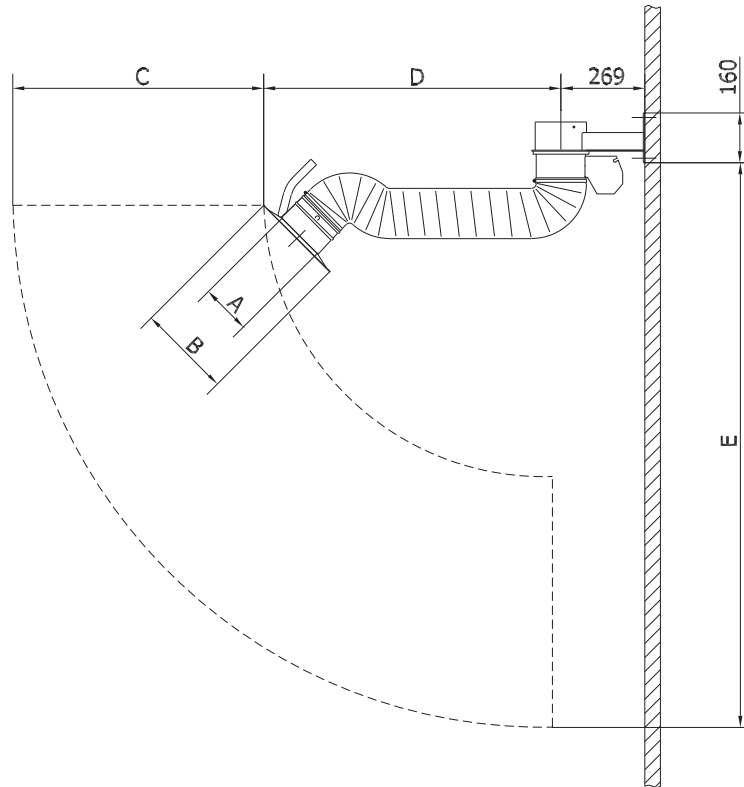

Order no.	Type	Hose diameter	A	B	C	D	E
01 994 500	TGI 2000	ø160mm	ø160	ø300	804	954	1812
01 995 500	TGI 2000	ø200mm	ø200	ø380	804	1017	1875

Telescopic arm type TGI with extension arm/single swing arm:

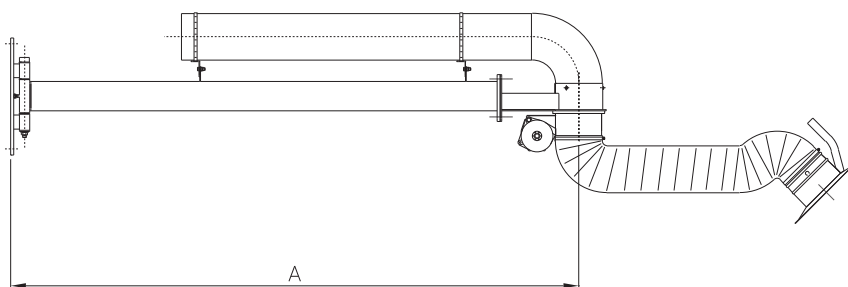

Type	A	Hose diameter	Range (ø160mm)
TGI 3000	1050	ø160-ø200mm	2808
TGI 4000	1950	ø160-ø200mm	3708

Recht auf Änderungen bleibt vorbehalten. / Data is subject to alterations.

Extension arm/double swing arm (can be folded together against wall):

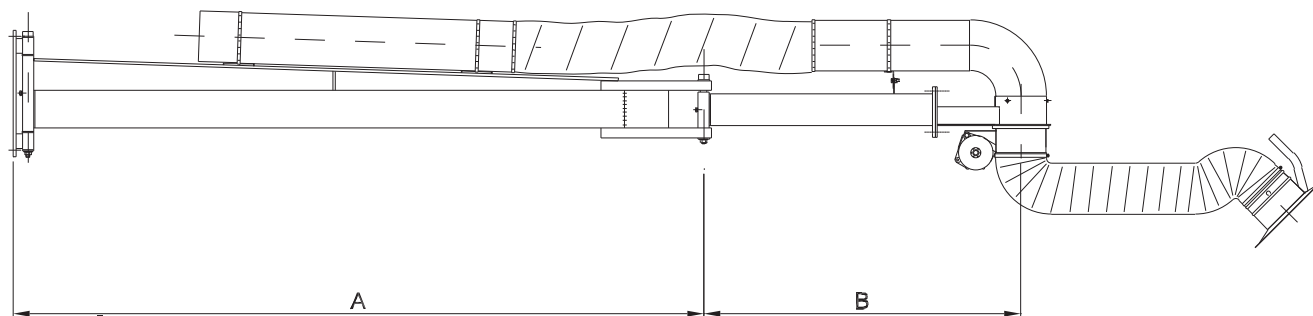

Type	A	B	Hose diameter	Range (ø160mm)
TGI 5000	2185	1000	ø160-ø200mm	4943
TGI 6000	2185	1885	ø160-ø200mm	5837
TGI 7000	3185	1895	ø160-ø200mm	6837

Pressure drop: Pa

Pressure drop TGI-telescopic arms

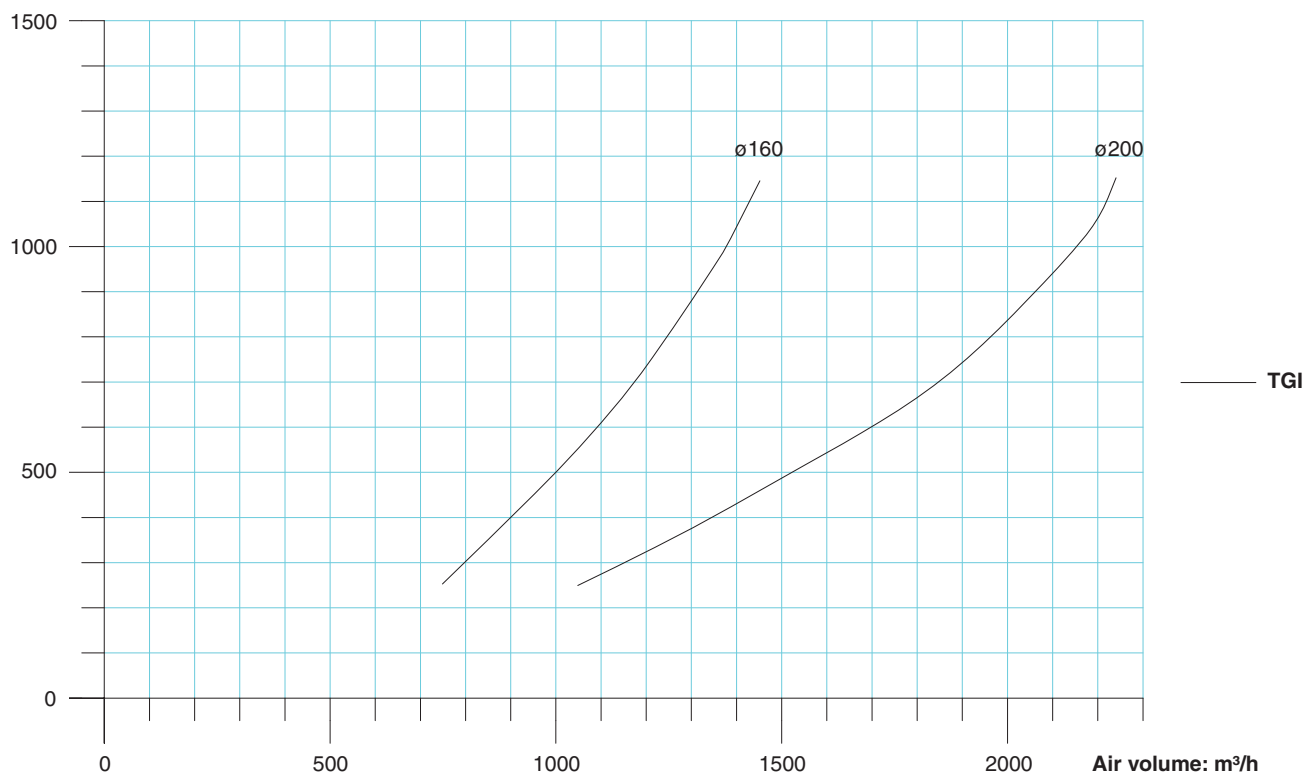

Performance table for cantilever joints for TGI (ø160 - ø200mm):

Diameter	ø160mm	ø200mm
at m³/h	1000	1600
1m joint	60 Pa	60 Pa
2m joint	70 Pa	70 Pa
2m + 1m joint	150 Pa	150 Pa
2m + 2m joint	185 Pa	185 Pa
3m + 2m joint	220 Pa	220 Pa

Recht auf Änderungen bleibt vorbehalten. / Data is subject to alterations.

Rev. 04.11