

GB

- Very large motion pattern - vertical
- RFF can rotate free 360° for hose relief
- Mountings for wall
- Length 2 - 4m is connected to channel by nipple
- Length 5 - 9m is connected to channel by hose (not inclusive)
- Suitable for welding smoke, light dust and gases
- With fixed-mounted, powder enamelled steel pipes for optimal flow and design
- Fan type VT/VL can be built-on
- Construction with external bar system
- Flow technical optimized hood

D

- Sehr großes Bewegungsmuster - senkrecht
- RFF kann frei 360° drehen
- Montagebeschlag für Wand
- Länge 2 - 4m wird mit Nippel an Kanal angeschlossen
- Länge 5 - 9m wird mit Schlauch an Kanal (nicht einschl.) angeschlossen
- Geeignet für Schweißrauch, leichten Staub und Gasen
- Mit festmontierten, pulverlackierten Stahlrohren für optimalen Flow und Design
- Ventilator Typ VT/VL kann angebaut werden
- Konstruktion mit Außen-Gestängesystem
- Strömungstechnisch optimierter Trichter



Built-on fan

Possibility for direct mounting of fan type VT/VL on extraction arm.



Quick coupling

Can be equipped with quick coupling for extension hose.



Extraction hood

Extraction hood is standard fitted with damper. Against additional payment automatic action switch and spotlight can be fitted.



Ceiling mounting

Ceiling brackets/extension pipe. Ceiling suspension up to 2 metres. Can revolve 360°

Aufgebauter Ventilator

Möglichkeit für Anbau von Ventilator Typ VT/VL direkt auf Absaugarm.

Schnellkupplung

Kann mit Schnellkupplung für Verlängerungsschlauch ausgestattet werden.

Absaugtrichter

Absaugtrichter Standard mit Absperrklappe. Gegen Zulage mit Licht und Start/Stop-Schalter.

Deckenmontage

Deckenbeschlag/Verlängerungsrohr für Deckenaufhängung bis zu 2 Meter. Drehbarkeit: 360°

Colour/Farbe: RAL 9005/9006 (structure/Struktur)

Recht auf Änderungen bleibt vorbehalten. / Data is subject to alterations.

Rev. 04.11

Extraction arm Punktabsaugarm

type
Typ

RFF

Diameter	Hose type*	Max. vacuum	Damper	See page
ø125-ø200mm	S1	1500 Pa	Yes	8.02



Hose type S1

* Special hoses are available

Type RFF 2000 - 4000:

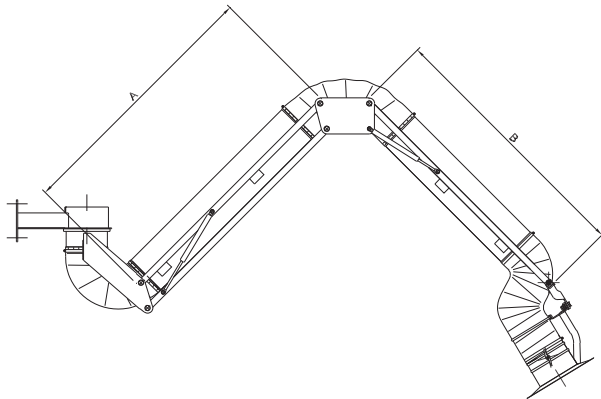

Type	Order no.	A	B
RFF 2000	01 370 600	500	450
RFF 3000	01 371 600	1000	900
RFF 4000	01 372 600	1500	1400

Range RFF 2000 - 4000 (ø160mm):

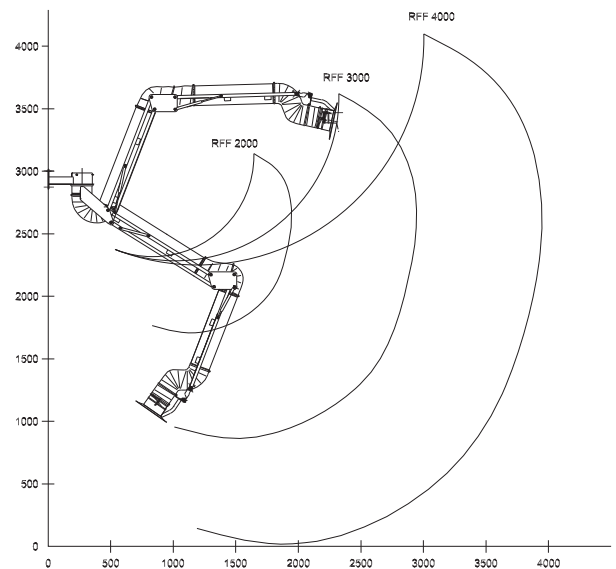

Extraction arm type RFF with extension arm/single swing arm:

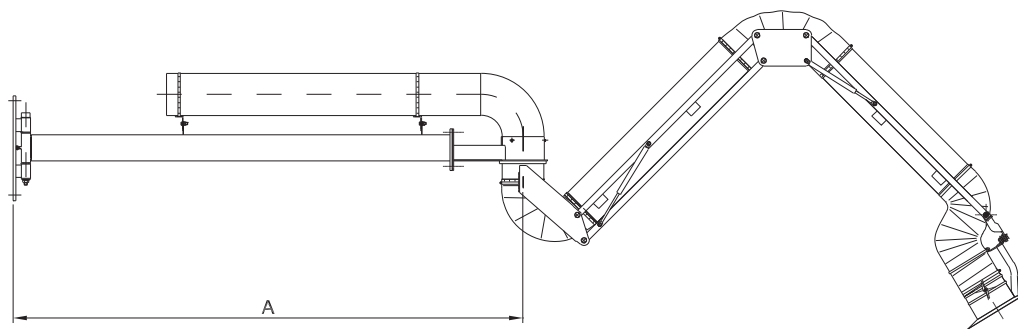

Type	A	Hose diameter	Range (ø160mm)
RFF 4000E	1050	ø125-ø200mm	3950
RFF 5000	1950	ø125-ø200mm	4850

Recht auf Änderungen bleibt vorbehalten. / Data is subject to alterations.
Rev. 04.11

Extraction arm Punktabsaugarm

type
Typ

RFF

Extension arm/double swing arm, max. 9m (can be folded together against wall):

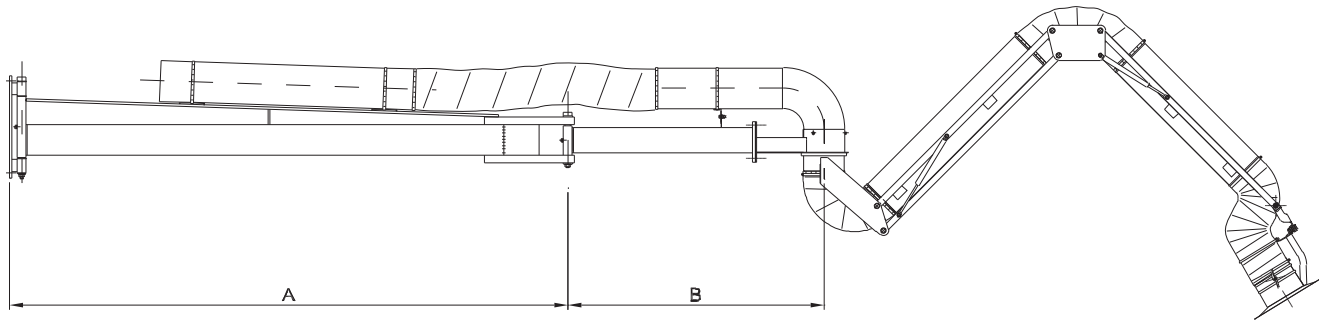

Type	A	B	Hose diameter	Range (ø160mm)
RFF 6000	2185	1000	ø125-ø200mm	6085
RFF 7000	2185	1895	ø125-ø200mm	6980
RFF 8000	3185	1895	ø125-ø200mm	7980
RFF 9000	3185	1895	ø125-ø200mm	8980

Extraction arm type RFF with lead-in mountings for table:

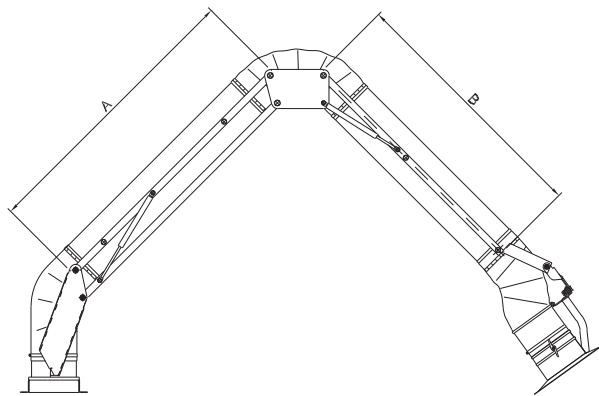

Type	A	B	Hose diameter
RFF 2000	500	450	ø125-ø160mm
RFF 3000	1000	900	ø125-ø160mm
RFF 4000	1500	1400	ø125-ø160mm

Range RFF 2000-4000 (ø160 mm):

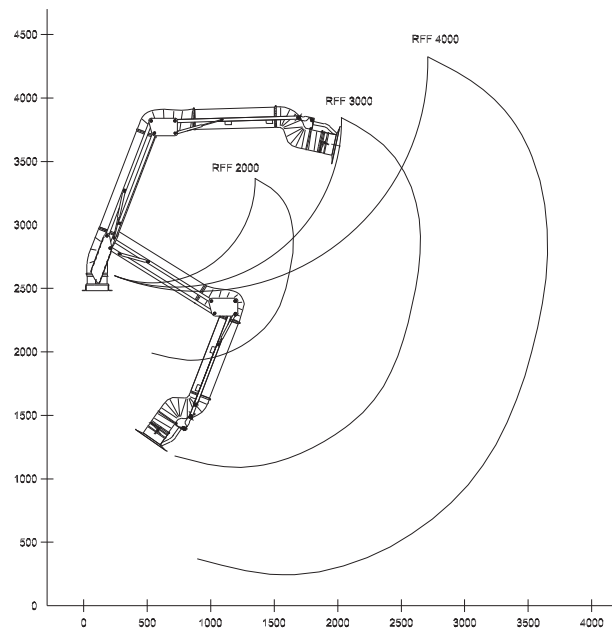

Performance curve for RFF 1000 - 4000 (ø125 - ø200mm):

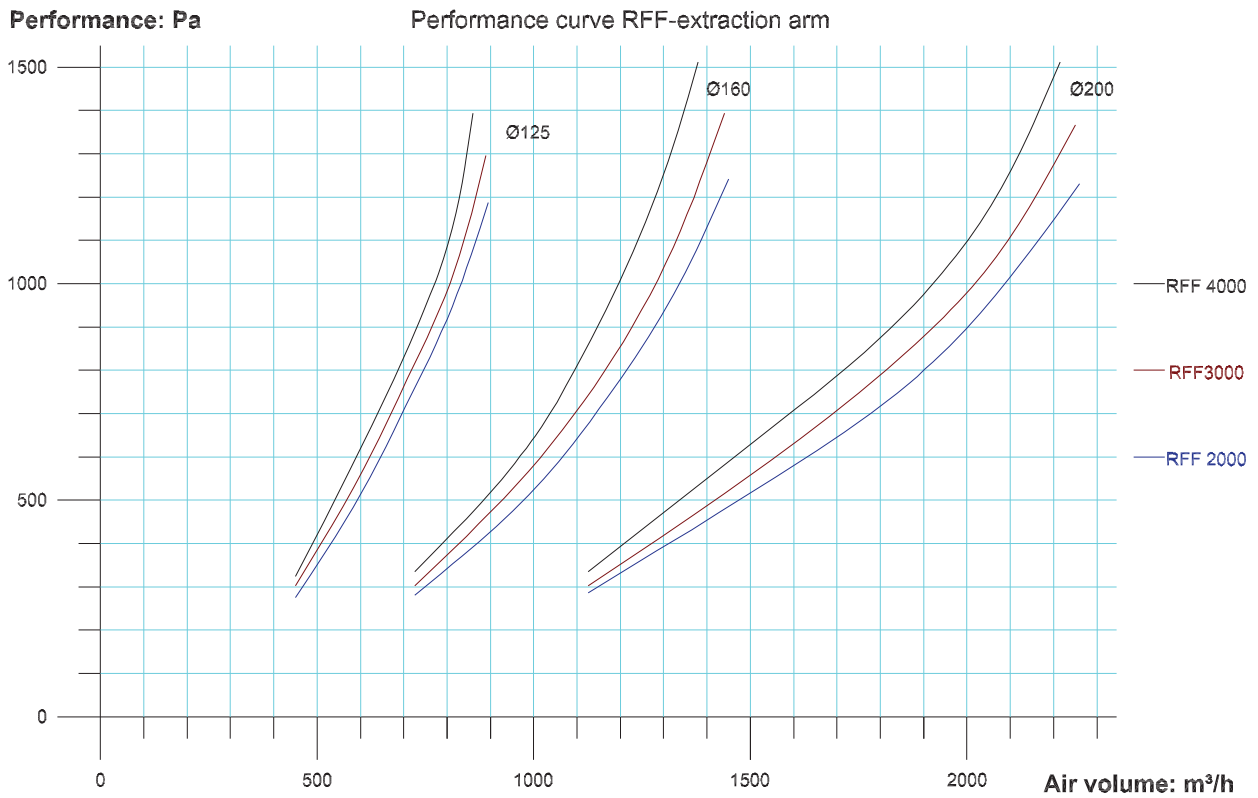

Performance table for cantilever joints for RFF (ø125 - ø160mm):

Diameter	ø125mm	ø160mm	ø200mm
at m³/h	600	1000	1600
2m joint	70 Pa	70 Pa	70 Pa
2m + 1m joint	150 Pa	150 Pa	150 Pa
2m + 2m joint	185 Pa	185 Pa	185 Pa
3m + 2m joint	220 Pa	220 Pa	220 Pa