



GB

- Large extraction surface
- Saving air volume
- Must be mounted on firm surface
- No wearing parts
- Is available in 2 standard models and 5 sizes
- Suitable for extraction of fumes, gases and lighter dust sorts

D

- Grosse Saugfläche
- Luftmenge-einsparend
- Muss auf fester Unterlage aufgestellt werden
- Keine Verschleißteile
- Wird in 2 Standard-Ausführungen und 5 Größen geliefert
- Geeignet zur Absaugung von Dämpfen, Gasen und leichteren Staubarten

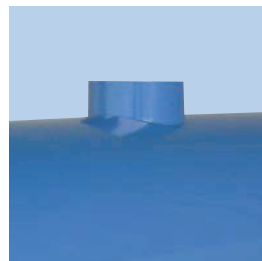
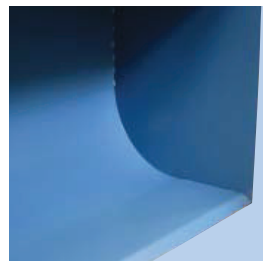

Model A

Turbo wall with straight backside for maximum work space.

Model B

Turbo wall with curved backside for optimal air flow.

Connection piece

Connection piece diameter from $\varnothing 125$ - $\varnothing 200$ mm.

Side plates

Side plates are available. See accessories.

Modell A

Turbowand mit gerader Rückwand für maximale Arbeitsfläche.

Modell B

Turbowand mit gekrümmter Rückwand, um die Saugleistung zu optimieren.

Stutzen

Stutzen-Diameter von $\varnothing 125$ - $\varnothing 200$ mm.

Seitenplatten

Seitenplatten sind erhältlich. Sehen Sie unter Zubehör.

Accessories:

Order no.	Description
02 476 000	Additional payment for slant cut side plates 400mm for GT 500/800/1000
02 476 100	Additional payment for slant cut side plates 400mm for GT 1500
02 476 200	Additional payment for slant cut side plates 400mm for GT 2000

Colour/Farbe: RAL 5007 (structure/Struktur)

Model/Modell A

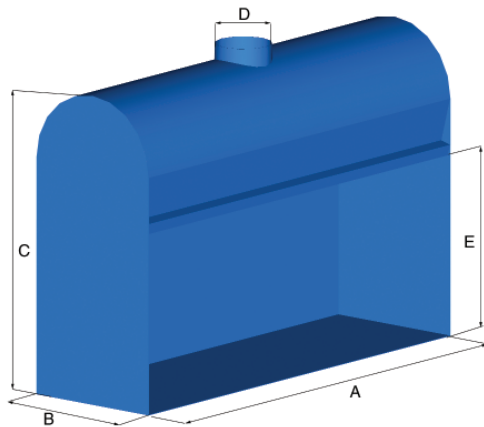

Model/Modell B

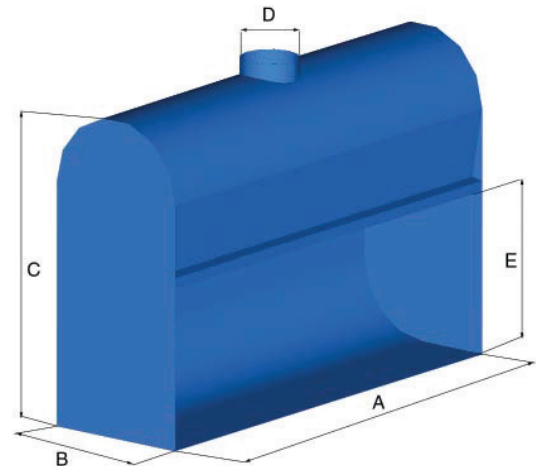

Type	Order no.	A	B	C	D	E	Backside (Form)	Minimum [m³/h]	Weight [kg]	Δ P [Pa]
GT 500/A	02 480 000	500	315	680	ø125	400	Straight	300	18	300
GT 500/B	02 481 000	500	315	680	ø125	400	Curved	300	18	300
GT 800/A	02 482 000	800	315	680	ø125	400	Straighth	400	24	300
GT 800/B	02 483 000	800	315	680	ø125	400	Curved	400	24	300
GT 1000/A	02 470 000	1000	315	680	ø125	400	Straight	500	28	300
GT 1000/B	02 471 000	1000	315	680	ø125	400	Curved	500	28	300
GT 1500/A	02 472 000	1500	400	900	ø160	550	Straight	1000	44	300
GT 1500/B	02 473 000	1500	400	900	ø160	550	Curved	1000	44	300
GT 2000/A	02 474 000	2000	450	1000	ø200	600	Straight	1500	59	300
GT 2000/B	02 475 000	2000	450	1000	ø200	600	Curved	1500	59	300

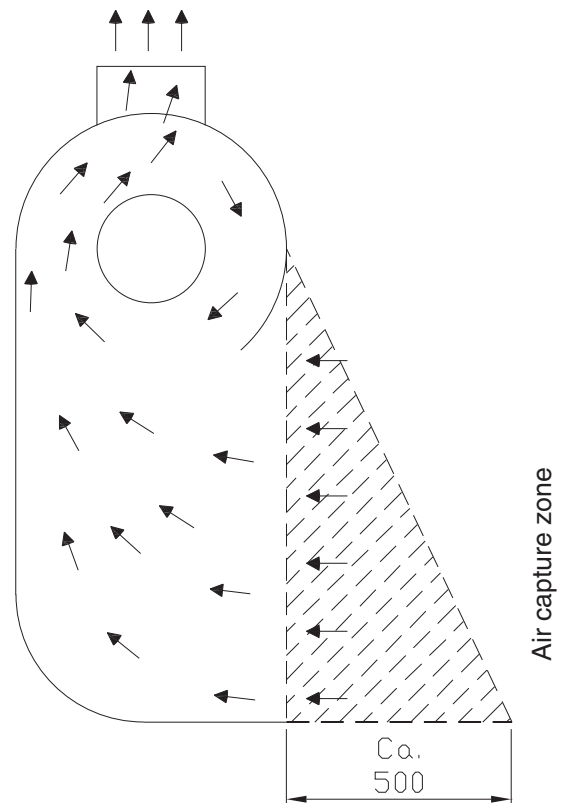
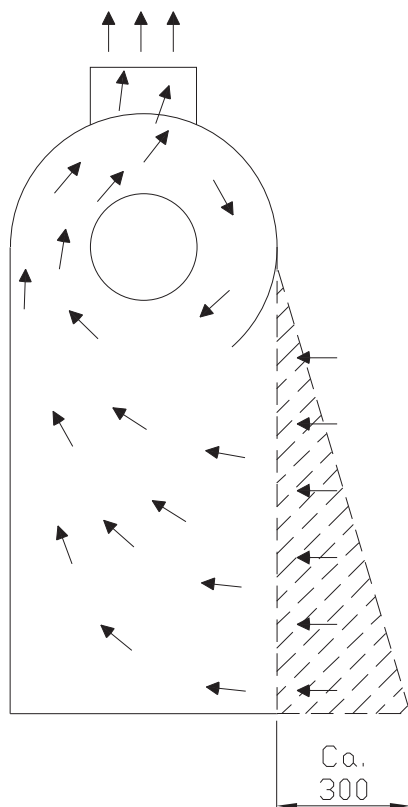

Recht auf Änderungen bleibt vorbehalten. / Data is subject to alterations.
Rev. 09.10