



GB

- Efficient filter unit with manual compressed air cleaning
- Equipped with fan type VL 1150, 1.10 kW
- Max. fan vacuum in standard version: 2,000 Pa
- Equipped with motor protection
- Delivered standard with filter cartridge G105, dust class M
- Made in powder enamelled steel
- Standard equipped with extraction arm type SA (exclusive damper in hood)
- Extraction arm can rotate 360°
- Spark arrest
- 1 pc. cable with plug
- Suitable for extraction air recirculation and therefore no application in Denmark (DK)

D

- Effiziente Filtereinheit mit manueller Druckluftreinigung
- Ausgestattet mit Ventilator Typ VL 1150, 1,10 kW
- Max. Ventilator-Vakuum in Standard-Ausführung: 2.000 Pa
- Ausgestattet mit Motorschutz
- Wird Standard mit Filterpatrone G105, Staubklasse M, geliefert
- Ausgeführt in pulverlackiertem Stahl
- Standard mit Punktabsaugarm Typ SA (ausschl. Klappe im Trichter) ausgerüstet
- Punktabsaugarm kann 360° drehen
- Funkenfang
- 1 Stck. Kabel mit Stecker
- Geeignet für Rezirkulation von abgasaugter Luft und darf deshalb in Dänemark (DK) nicht verwendet werden



Extraction arm
Arm is delivered with flow technical optimized hood and internal bar system



Motor protection
Integrated motor protection.



Service
Easy service of dust container.



Outlet
Noise damped outlet with diffused exhaust.

Colour/Farbe: RAL 5007/7011 (structure/Struktur)



Punktabsaugarm
Arm wird mit strömungstechnisch optimiertem Trichter und Innen-Gestängesystem geliefert.



Motorschutz
Integrierter Motorschutz und Alarm.



Wartung
Einfache Wartung von Staubschublade.



Abluft
Schallgedämpfte Abluft mit diffusem Ausblasen.

Mobile filter unit type SFPM:

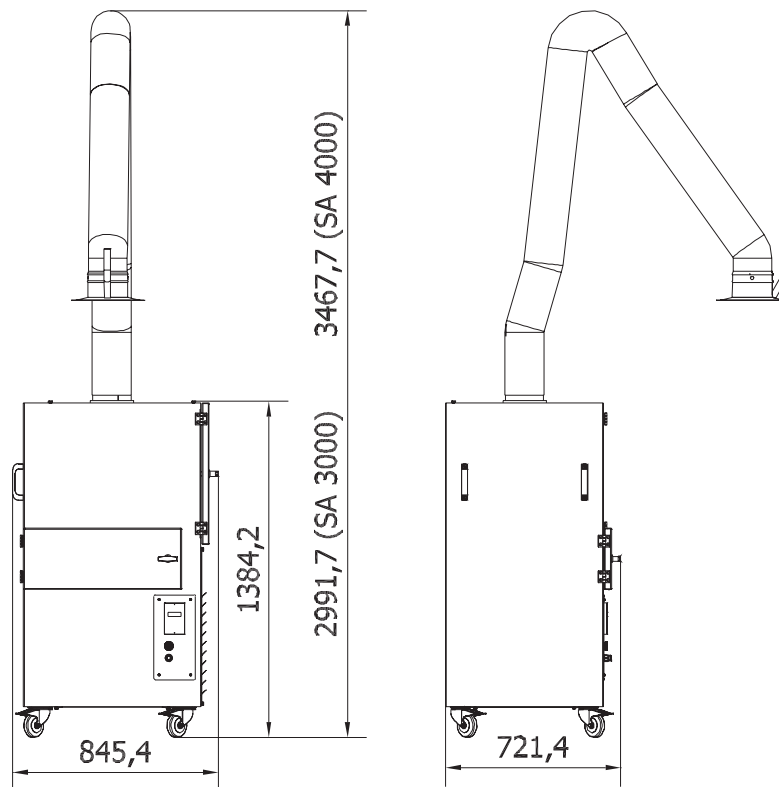

Type	Order no.	Fan	Motor [kW]	Voltage [V]	Arm type	Filter	Filter material*
SFPM1	04 142 500	VL 1150	1.10	1x230	SA 3000/ø160	1 x 21 m ²	G105
SFPM1	04 142 550	VL 1150	1.10	1x230	SA 4000/ø160	1 x 21 m ²	G105

* Filter type: Jet filter cartridge ø325x660mm/ø13,5mm, 21m², G105 (08 128 000).
For other filter materials - see price list.

Recht auf Änderungen bleibt vorbehalten. / Data is subject to alterations.

Rev. 04.11



GB

Filter unit type SFPM for wall mounting

- Delivered inclusive wall fittings

D

Filteranlage Typ SFPM für Wandmontage

- Wird einschl. Wandbeschläge geliefert

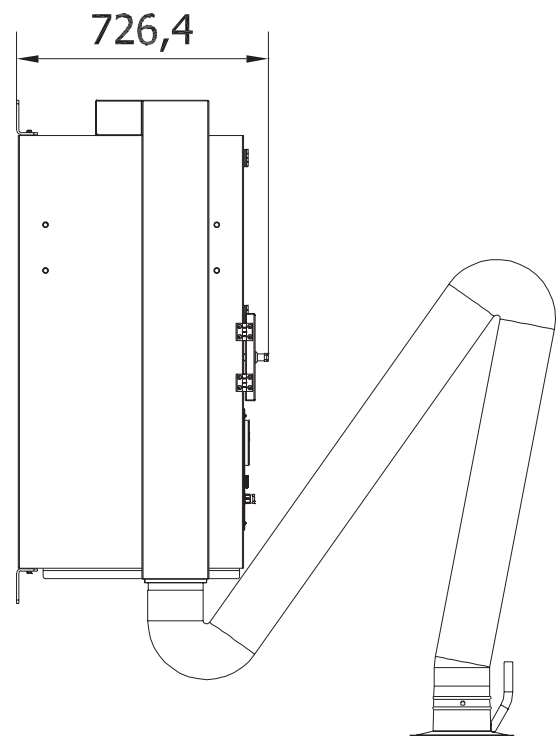
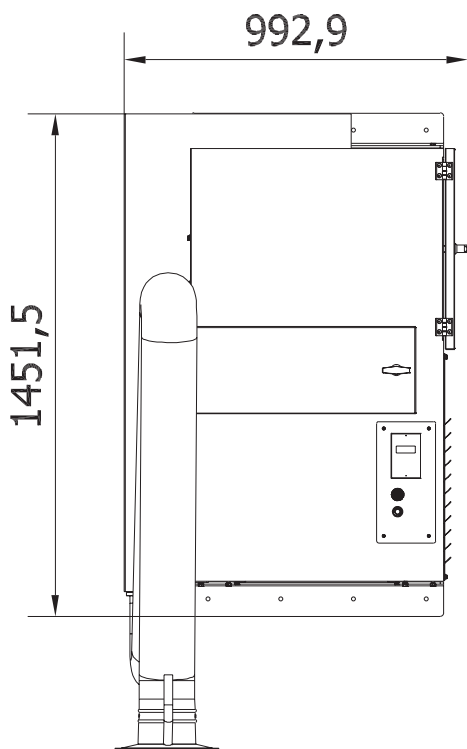

Type	Order no.	Fan	Motor [kW]	Voltage [V]	Arm type	Filter	Filter material*
SFPM1	04 143 500	VL 1150	1.10	1x230	SA 3000/ø160	1 x 21 m ²	G105
SFPM1	04 143 550	VL 1150	1.10	1x230	SA 4000/ø160	1 x 21 m ²	G105

* Filter type: Jet filter cartridge ø325x660mm/ø13,5mm, 21m², G105 (08 128 000).
For other filter materials - see price list.

Recht auf Änderungen bleibt vorbehalten. / Data is subject to alterations.
Rev. 04.11