

RK250-7

CITY CRANE

RK250

Max. Lifting Capacity: 25.0 metric ton at 3.5 m
Max. Boom Length: 30.62 m

KOBELCO



Note: Optional items shown above may change without notice.

SPECIFICATIONS

CRANE PERFORMANCE		
Max. rated load	7.35 m boom	25,000 kg x 3.5 m (7 parts)
	12.00 m boom	20,300 kg x 3.5 m (6 parts)
	16.66 m boom	19,000 kg x 4.0 m (6 parts)
	21.31 m boom	14,450 kg x 4.0 m (4 parts)
	25.97 m boom	10,450 kg x 5.5 m (4 parts)
	30.62 m boom	7,000 kg x 8.0 m (4 parts)
	5.8 m jib	4,000 kg x 10.6 m (1 part)
	8.9 m jib	2,300 kg x 14.0 m (1 part)
	12.0 m jib	2,000 kg x 12.0 m (1 part)
	Auxiliary sheave	4,000 kg (1 part)
Max. lifting height	25 t hook (Main boom)	31.5 m
	4 t ball hook (Twist jib)	43.2 m
Max. working radius	Boom	28.2 m
	Jib	33.6 m
Main boom length	7.35 m to 30.62 m	
Boom telescoping speed	100 sec/23.27 m	
Jib length	5.8 m, 8.9 m, 12.0 m	
Line speed	Main: 122 m/min at 4th layer, Aux.: 107 m/min at 1st layer	
Line pull	4,200 kg at 5th layer	
Boom raising speed	49.6 sec/ -8° to 82°	
Swing speed	1.9 min ⁻¹ (1.9 rpm)	
CRANE MAIN STRUCTURE		
Main boom	Box type, 6 sections, 2nd, 3rd, and 4th singly and 5th and 6th simultaneous telescoping Hydraulic telescoping, use in combination with wire rope	
Jib	Side storage, compressed truss and box type, 2nd and 3rd drawing out type. Sky tilt jib: hydraulic no-step tilt type (3° to 45°) Manual jib (optional): 3 step variable tilt type (5°, 25°, 45°)	
Aux. sheave	Mounted on boom tip, upward storage, hook winding up type	
Winch system	Hydraulic motor drive, planetary gear reduction and automatic brake, independent 2 winches (without free-fall) High to low variable speed	
Boom hoist system	Direct forced type by double acting hydraulic cylinder (-8° ~ 82°)	
Swing system	Hydraulic motor drive, planetary gear reduction type, with parking (negative) brake, half-free/lock selectable	
Outriggers	Type	All hydraulic, H-type or X-type
	Extension width	H-type: 6.3 m/5.9 m/5.1 m/3.8 m/2.12 m X-type: 6.3 m/5.9 m/5.1 m/3.8 m/2.98 m

WIRE ROPE		
Main	Ø 16 mm x 170 m IWRC 6 x Fi (29) C/O anti-twist	
Aux.	Ø 16 mm x 90 m IWRC 6 x WS (26) C/O anti-twist	
HYDRAULIC SYSTEM		
Hydraulic pumps	for travel	2 variable displacement plunger pumps for travel, and 3 gear pumps for steering and one gear pump for emergency steering
	for crane	2 variable displacement plunger pumps, and 3 gear pump
Hydraulic oil tank	410 liters	
CARRIER PERFORMANCE		
Max. travel speed	49 km/h	
Gradeability	High gear: 19 % (11°) /Low gear: 50 % (27°)	
Min. turning radius	Normal steering	8.5 m
	Cramp steering	4.8 m
Engine	Make/model	HINO J08E-TM
	Type	Water cooled, 4 cycle, 6 cylinders, direct injection diesel with turbocharger, intercooler
	Displacement	7,684 liters
	Max. output	209 kW/2,100 min ⁻¹ {284 PS/2,100 rpm}
	Max. torque	998 Nm/1,600 min ⁻¹ {102 kgf m/1,600 rpm}
CARRIER MAIN STRUCTURE		
Travel drive	All wheel drive and steering (4 x 4)	
Transmission	Type	HST (Hydrostatic transmission), full-time 4 wheel drive
	No. of speed shift	CVT by HST + High/Low 2-step
Axles	All axles steered and driven by variable displacement hydraulic motors, differential locks for transverse lock. 2-step axle intermediate gear	
Suspension	Hydro-pneumatic suspension (with hydraulic cylinder)	
Steering	Type	All hydraulic power steering with emergency steering device and about-face steering compensation device
	Mode	Normal (front 2W), clamp (4W), crab (4 W) and rear (2W)
Brake	Main service brake	Internal expansion drum type with full air booster, on all wheels
	Aux. brake	HST brake
	Parking brake	Spring locked type, acting on all wheels
Tires (front and rear)	385/95 R25 170E ROAD	
Fuel tank	300 liters	

LIFTING CAPACITIES

MAIN BOOM

Main boom length: 7.35 - 30.62 m
 Outriggers: 6.3 m position
 Swing area: 360°

Unit: ton

Boom length (m)	7.35	12.00	16.66	21.31	25.97	30.62
2.5	25.00	20.30				
3.0	25.00	20.30	19.00	14.45		
3.5	25.00	20.30	19.00	14.45		
4.0	22.40	19.75	19.00	14.45	10.45	
4.5	20.00	19.10	18.00	13.85	10.45	
5.0	11.50/4.9m	18.50	16.70	13.20	10.45	7.00
5.5		16.90	15.60	12.60	10.45	7.00
6.0		15.50	14.60	12.00	10.00	7.00
6.5		14.30	13.80	11.50	9.60	7.00
7.0		13.20	13.00	10.95	9.20	7.00
7.5		12.20	12.20	10.40	8.80	7.00
8.0		10.65	10.70	9.80	8.40	7.00
8.5		9.35	9.60	9.30	8.05	6.70
9.0		8.25	8.55	8.80	7.70	6.40
9.5		7.20	7.65	8.10	7.40	6.15
10.0			6.90	7.30	7.10	5.90
11.0			5.65	6.05	6.55	5.35
12.0			4.70	5.10	5.55	4.90
13.0			3.90	4.30	4.75	4.50
14.0			3.30	3.70	4.10	4.15
15.0			3.15/14.2m	3.15	3.55	3.85
16.0				2.70	3.10	3.35
17.0				2.30	2.75	2.95
18.0				1.90	2.40	2.60
19.0				1.60/18.8m	2.10	2.35
20.0					1.80	2.10
22.0					1.30	1.60
24.0					1.00/23.5m	1.25
26.0						0.95
28.0						0.70
30.0						0.70/28.2m

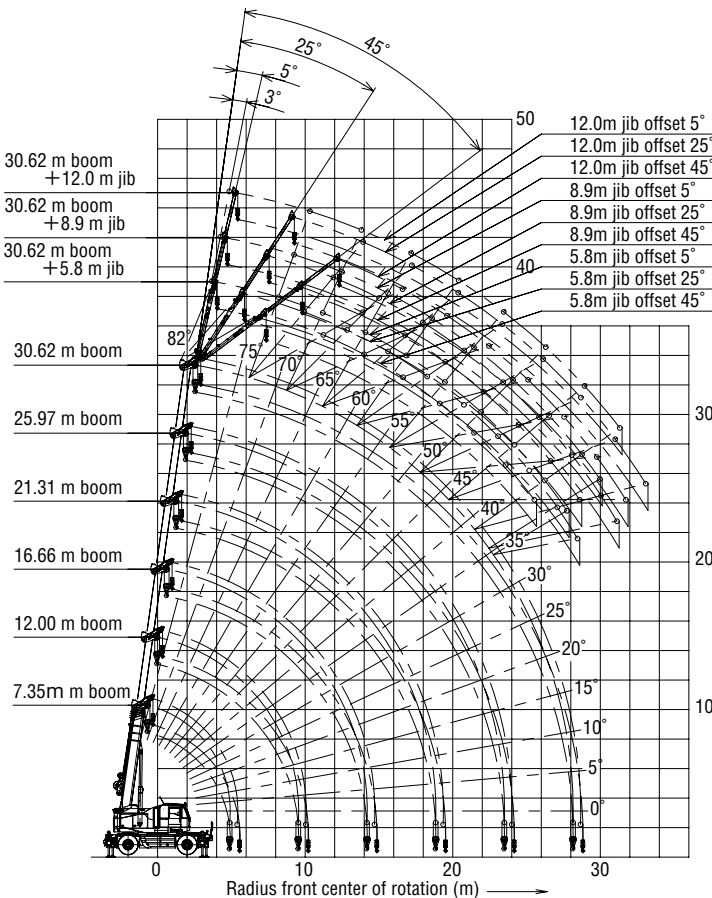

Boom and jib geometry shown does not reflect any deflection of boom and jib. Boom deflection and subsequent radius and boom angle change must be accounted for when at actual operation.

LIFTING CAPACITIES

TWIST JIB

Main boom length: 30.62 m
 Jib length: 5.8, 8.9, 12.0 m
 Outriggers: 6.3 m position
 Swing area: 360°

Unit: ton

Jib length (m)	5.8 m					
Jib angle (°)	3 to 5		25		45	
	Operating radius (m)	Lifting capacity (kg)	Operating radius (m)	Lifting capacity (kg)	Operating radius (m)	Lifting capacity (kg)
82.0	5.1	4.00	6.9	3.10	8.4	2.13
80.0	6.5	4.00	8.3	3.10	9.6	2.13
75.0	9.7	4.00	11.4	3.10	12.6	2.04
73.5	10.6	4.00	12.3	2.95	13.5	2.01
71.0	12.0	3.80	13.7	2.73	14.8	1.98
70.0	12.6	3.63	14.2	2.65	15.3	1.97
69.0	13.2	3.48	14.8	2.57	15.9	1.96
65.0	15.5	2.93	17.0	2.29	17.9	1.92
62.0	17.1	2.60	18.5	2.12	19.4	1.86
60.0	18.2	2.29	19.5	2.01	20.3	1.79
56.0	20.2	1.70	21.5	1.56	22.2	1.50
55.0	20.7	1.58	22.0	1.45	22.6	1.40
53.0	21.7	1.36	22.9	1.25	23.4	1.21
52.0	22.2	1.26	23.3	1.16	23.9	1.13
50.0	23.1	1.07	24.2	1.00	24.7	0.97
48.0	24.0	0.91	25.0	0.85	25.4	0.83
45.0	25.3	0.70	26.2	0.65	26.4	0.64
40.0	27.2	0.41	27.9	0.39		
37.0	28.3	0.28	28.7	0.26		
Min. boom angle	37°		37°		45°	

Unit: ton

Jib length (m)	8.9 m					
Jib angle (°)	3 to 5		25		45	
	Operating radius (m)	Lifting capacity (kg)	Operating radius (m)	Lifting capacity (kg)	Operating radius (m)	Lifting capacity (kg)
82.0	5.8	2.30	8.7	2.10	11.0	1.40
80.0	7.2	2.30	10.1	2.10	12.3	1.40
75.0	10.8	2.30	13.4	1.82	15.3	1.35
73.5	11.8	2.30	14.3	1.74	16.2	1.33
71.0	13.4	2.30	15.9	1.62	17.6	1.30
70.0	14.0	2.30	16.5	1.57	18.2	1.28
69.0	14.6	2.28	17.1	1.53	18.7	1.27
65.0	17.1	1.95	19.4	1.39	20.8	1.20
62.0	18.8	1.76	21.0	1.30	22.4	1.15
60.0	20.0	1.65	22.1	1.25	23.3	1.12
56.0	22.2	1.47	24.2	1.16	25.2	1.06
55.0	22.7	1.37	24.7	1.14	25.6	1.05
53.0	23.8	1.17	25.6	1.05	26.5	1.00
52.0	24.3	1.08	26.1	0.97	26.9	0.93
50.0	25.3	0.92	27.0	0.83	27.7	0.80
48.0	26.3	0.77	27.9	0.70	28.5	0.68
45.0	27.7	0.58	29.1	0.53	29.5	0.52
40.0	29.8	0.33	31.0	0.30		
39.0	30.2	0.29	31.4	0.26		
38.0	30.6	0.25				
Min. boom angle	38°		39°		45°	

Unit: ton

Jib length (m)	12.0 m					
Jib angle (°)	3 to 5		25		45	
	Operating radius (m)	Lifting capacity (kg)	Operating radius (m)	Lifting capacity (kg)	Operating radius (m)	Lifting capacity (kg)
82.0	7.1	2.00	10.7	1.25	13.6	1.00
80.0	8.5	2.00	12.1	1.25	14.9	1.00
75.0	12.0	2.00	15.6	1.18	18.1	1.00
73.5	13.1	1.87	16.6	1.15	19.0	1.00
72.0	14.1	1.75	17.5	1.12	19.9	0.97
71.0	14.8	1.70	18.2	1.10	20.5	0.95
69.0	16.1	1.58	19.4	1.06	21.6	0.91
65.0	18.8	1.40	21.9	1.01	23.8	0.84
60.0	21.9	1.20	24.8	0.94	26.4	0.74
55.0	24.9	1.10	27.5	0.88	28.7	0.64
53.0	26.0	1.03	28.5	0.85	29.6	0.60
52.0	26.6	0.95	29.0	0.84	30.0	0.58
51.0	27.1	0.87	29.4	0.77	30.5	0.56
50.0	27.6	0.80	29.9	0.71	30.9	0.54
48.0	28.7	0.67	30.8	0.60	31.6	0.50
45.0	30.2	0.50	31.9	0.45	32.6	0.44
41.0	32.0	0.32	33.3	0.28		
40.0	32.5	0.27	33.6	0.25		
Min. boom angle	40°		40°		45°	

Lifting capacity

Stationary: Max., Operating radius 3.0 m

Swing area	Stationary			
	360			
Boom length (m)	7.35	12.00	16.66	21.31
Lifting capacity (ton)	7.65	7.50	7.30	4.50

Stationary: Max., Operating radius 3.0 m

Swing area	Stationary			
	Over the front			
Boom length (m)	7.35	12.00	16.66	21.31
Lifting capacity (ton)	14.00	14.00	9.00	6.50

Pick & Carry: Max., Operating radius 3.0 m

Swing area	Pick & Carry (under 2 km/h)			
	360			
Boom length (m)	7.35	12.00	16.66	21.31
Lifting capacity (ton)	7.65	6.40	5.10	3.20

Pick & Carry: Max., Operating radius 3.0 m

Swing area	Pick & Carry (under 2 km/h)			
	Over the front			
Boom length (m)	7.35	12.00	16.66	21.31
Lifting capacity (ton)	13.80	10.50	7.50	5.50

Steering

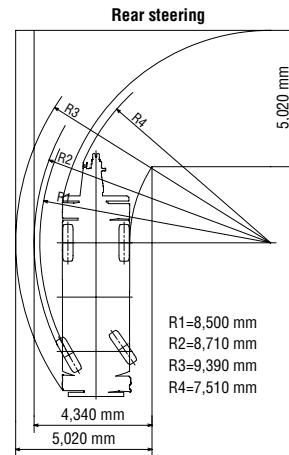
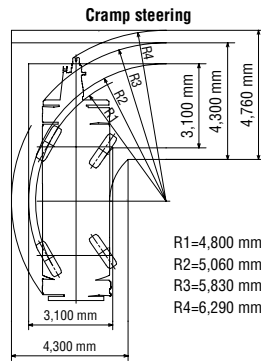
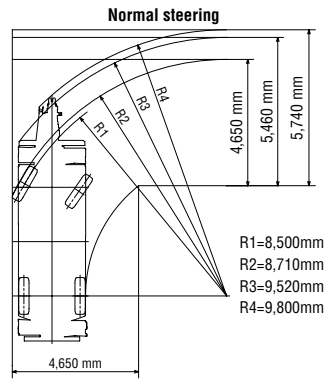

Reference

Ratings according to Japanese Construction Codes for mobile cranes and Japanese Safety Ordinance on Cranes, etc.

Classification of the crane

The crane is classified as follows. (ISO 4301-2 or FEM 1.001):

- Operating classification → U2
- Collective classification → Q2
- Crane group → A1

All the major components of the crane are designed and manufactured for standard construction operations. It is assumed that there is a normal working time relation between the maximum usage of the crane, work periods with relatively light usage of the crane, and the rest periods for the machinery; this ratio should be a value which is typical for an erection crane. Under more severe operating conditions, a shorter service life would be inevitable and must be expected. If the crane will be used under uncommon operating conditions or for special tasks which are different from standard assembly work, the prior approval of manufacturer must be obtained; in such a case, it can be assumed that the load carrying capacity will be restricted.

Notes

- The rated crane load is the maximum lifting capacity when the crane is set on firm and level ground and includes the weight of the hook block, sling wire, etc.
Area marked with \square indicates that the rated load is decided by machine stability.
- In the area where the chart is blank, crane lifting can not be done there.
If the boom is lowered exceeding the minimum boom angle, crane may turnover even without load. Take extra care not to do this.
- If the required boom length for actual work exceeds the specified boom length or one rank above that boom length, whichever the rated load is smaller.
- The crane load of aux. sheave is equal to that of the boom rated load minus 25 ton hook weight (200 kg) and limited to 4,000 kg.
- Operating radius is horizontal distance from swing center to the gravity point of the load.
- Radius shown on the above capacity chart are on actual base taking in account of boom and jib deflection under loaded condition at 100% of rated load.
When using boom only, always refer to radius over your operation.
- Type of the hooks and their weight is as per the following table.

Kind of hooks	25 ton	4.0 ton
Weight	200 kg	70 kg

- Minimum no. of reeving part of the hook is determined so that the sling line load does not exceed 4,000 kg.
The maximum reeving for each boom length is shown below.

Boom length	7.35 m	12.00 m	16.66 m	21.31 m	25.97 m	30.62 m	Jib/aux. sheave
Used hook	25.0 hook						4.0 ton hook
No. of reeving	7	6	6	4	4	4	1

OPERATION WITHOUT OUTRIGGERS (ON TIRE)

- The rated crane load means the maximum load that the crane can lift when the air pressure of tires is at the specified pressure on firm and level ground and when the suspension cylinder is retracted to the maximum rate and includes the weight of the hook block and sling wire, etc.
The \square part is decided by the strength of machine and other area are decided by the stability of the crane body.
(Tires specified air pressure: 900 kPa)
- The rated crane load is different in capacity at the forward and lateral directions. When the crane swings from the forward area to the lateral area, take extra care because the crane may be overloaded.

OVER FRONT



On tire	Stationary lifting	Pick and carry
Area α°	1°	1°

- Do not attempt the operation with jib.
- Operate the lifting work at the fixed position with the parking brake engaged.
- Operate the lifting work during propelling with the high and low selector switch set to the low range.
- Operate the lifting work during propelling so that it is not swung while holding the load close to the ground at a speed of 2 km/h or lower.
Special care should be taken on the cornering, sudden acceleration and braking.
- Do not attempt the crane operation through the lifting work during propelling.

OPERATION WITH OUTRIGGERS

- The maximum extension width of outrigger is 6.3 m, medium extension width is 5.9 m, 5.1 m and 3.8 m. The minimum extension width is 2.12 m for H type and 2.98 m for X type.
- The lifting capacity in side areas may differ depending on the extending condition of outriggers.
If the extension width is different depending on the right and left, front and rear outriggers, carry out operation under the rated crane load according to the right front and rear outriggers with less extension width in the right side area, and the left front and rear outriggers with less extension width in the left side area.
For the lifting capacity in the front and rear areas, make sure to work following the rated crane load chart with the outriggers maximum extension. However, the rated crane load indicated by the load safety device in the lateral area is designed to change continuously from the forward, backward to the lateral area by the calculation excluding the outriggers minimum extension width.

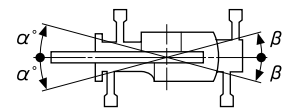

Outrigger extension condition	MID extension (5.9m)	MID extension (5.1m)	MID extension (3.8 m)	Minimum extension (H type 2.12 m) (X type 2.98 m)
Area α°	31	27	19	H 7 X 14
Area β°	31	27	19	H 7 X 14

- When using jib, the above chart shows only the actual radius under 30.62 m boom, therefore, always refer to boom angle when operating jib with boom length shorter than 30.62 m.
- In case of jib work, jib rated load 4.0 ton minus ball hook weight and sling wire rope weight should be used.
- In case of boom work with jib extended, boom rated load minus lifting sling weight and 1,200 kg should be used in case of 1 to 3 step jib extended condition.
- Do not use aux. sheave when the jib extended.
- Regarding stability in the oblique direction (outrigger direction), the outrigger float at the diagonal position against the lifted load may float depending of the condition during lifting work in the oblique direction (Outrigger direction). This phenomenon is caused due to the torsional rigidity of carrier frame and deflection and not by the loss of stability. This crane is set and operated horizontally on firm and level ground through out the work within the rated crane load and the stability is ensured. The oblique (outrigger direction) means the direction of (1) to (4).

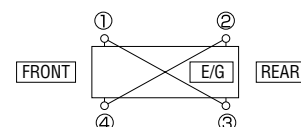

Warning

RK250 is designed for lifting purpose only. Do not use and/or lift attachments which cause vibration or shock.
The machine may be damaged.

General Dimensions (Unit: mm)

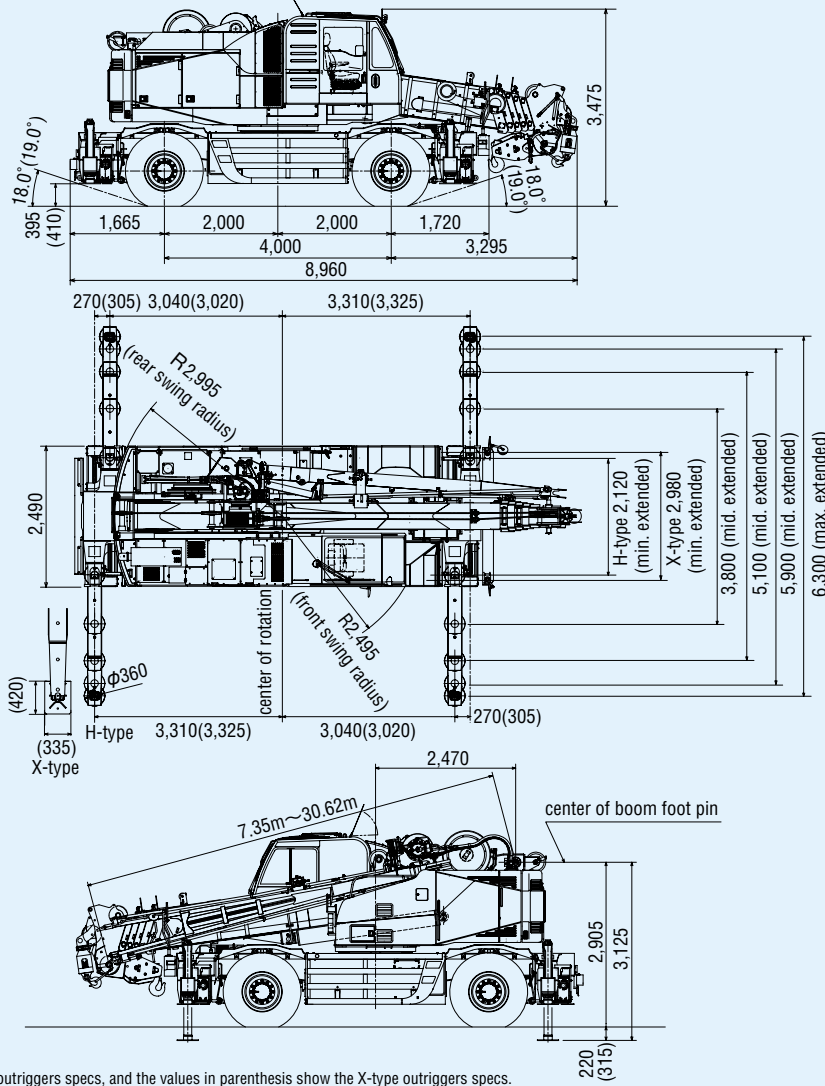

WEIGHT	
Total weight	25,955 kg
Front axle load	12,995 kg
Rear axle load	13,000 kg

*Figures show the H-type outriggers specs, and the values in parenthesis show the X-type outriggers specs.

SAFETY DEVICE

Crane System

- Moment limiter (auto-stop)
- Overhoist prevention device (auto-stop)
- Swing automatic stop device
- Working range limit device
- Swing brake
- Interceptive lever lock for on and off
- Check & Safety Monitor
- Sling wire lock
- Auxiliary hoist drum camera
- Overload state record
- Emergency directly connected cable

Travel System

- Rear view camera
- Emergency steering pump
- Rear steering auto-lock
- Suspension lock device
- Engine overrun warning device
- Reverse sound alarm
- Seat belt

STANDARD EQUIPMENT

- Spotlights
- Auxiliary hoist drum/ rear view camera
- Reverse sound alarm
- Hook block 25t (3-sheave)
- Hook block 4t (ball)
- Tacho-graph (analog)
- Tools
- Twist jib hydraulically tilt
- Auxiliary sheave
- Centralized greasing system
- One way call
- Outrigger-pads (rubber type)
- Grease gun
- Air conditioner
- Main and auxiliary winch
- Foot pedals (boom raise/lower, auxiliary hoist)
- Outrigger control box (left side)
- Radio and antenna (Japanese type)

OPTIONAL EQUIPMENT

- Twist jib, manually tilt
- Stowage box
- Spare wheel: 385/95 R25
- Spare rim: 385/95 R25
- Radio and antenna (on request)
- Fire extinguisher (on request)
- ABS (on request)

*Optional equipment may vary by countries.

Note: This catalog may contain photographs of machines with specifications, attachments and optional equipment not certified for operation in your country. Please consult KOBELCO for those items you may require. Due to our policy of continual product improvements all designs and specifications are subject to change without advance notice.

Copyright by KOBELCO CRANES CO., LTD. No part of this catalog may be reproduced in any manner without notice.

KOBELCO CRANES CO., LTD.

17-1, Higashigotanda 2-chome, Shinagawa-ku, Tokyo 141-8626 JAPAN
 Tel: +81-3-5789-2130 Fax: +81-3-5789-3372
 URL: <http://www.kobelco-cranes.com/>

Inquiries To: