

RKE450-3.1 EUR

CITY CRANE**RKE450****Max. Lifting Capacity: 45.0** metric ton at 2.5 m****Max. Boom Length: 34.0 m****KOBELCO**

Note: Optional items shown above may change without notice.

SPECIFICATIONS

CRANE PERFORMANCE		
Max. rated load	7.90 m boom (over front/over rear)	45,000 kg** x 2.5 m (10 parts) 40,000 kg* x 2.5 m (10 parts)
	7.90 m boom (all around)	35,000 kg x 3.0 m (10 parts)
	10.51 m boom	24,500 kg x 5.0 m (7 parts)
	13.12 m boom	22,500 kg x 5.0 m (7 parts)
	18.34 m boom	17,000 kg x 6.0 m (5 parts)
	23.56 m boom	15,000 kg x 6.0 m (4 parts)
	28.78 m boom	11,400 kg x 8.0 m (3 parts)
	31.39 m boom	9,450 kg x 8.0 m (3 parts)
	34.00 m boom	7,200 kg x 10.0 m (3 parts)
	Max. lifting height	25 t hook (Main boom)
4 t ball hook (Twist jib)		44.4 m
Max. working radius		
Max. working radius	Boom	31.1 m
	Jib	36.0 m
Main boom length	7.90 m to 34.0 m	
Boom telescoping speed	120 sec/26.1 m	
Jib length	6.3 m, 10.2 m (1.2 m: Heavy duty jib)	
Line speed	120 m/min at 4th layer, 98 m/min at 1st layer	
Line pull	4,500 kg at 5th layer	
Boom raising speed	55 sec/ - 9° to 80°	
Swing speed	2.1 min ⁻¹ (2.1 rpm)	
CRANE MAIN STRUCTURE		
Main boom	Box type, 6 sections, 2nd, 3rd and 4th singly, and 5th and 6th simultaneous telescoping Hydraulic telescoping, use in combination with wire rope	
Jib	Side storage, compressed truss and box type, 2nd drawing out type. Manual jib, 3 step variable tilt type (5°, 25°, 45°)	
Winch system	Hydraulic motor drive, planetary gear reduction and automatic brake (without free-fall). High to low variable speed	
Boom hoist system	Direct forced type by double acting hydraulic cylinder (-8°~ 82°)	
Swing system	Hydraulic motor drive, planetary gear reduction type with pedal brake and parking brake.	
Outriggers	All hydraulic H-type Extension width: 6.47/6.10/5.10/3.60/2.17 m	
WIRE ROPE		
Main	φ 16 mm x 160 m, P·S (19) + 39 x P·7	
HYDRAULIC SYSTEM		
Hydraulic pumps	for travel	2 variable displacement plunger pumps for travel, and 2 gear pumps for steering and 1 gear pump for emergency steering
	for crane	2 variable displacement plunger pumps and 3 gear pumps
Hydraulic oil tank	558 liters	
CARRIER PERFORMANCE		
Max. travel speed	80 km/h	
Gradeability	High gear: 19 % (11°) / Low gear: 50 % (27°)	
Min. turning radius	Over outside front bumper	8.02 / 6.51 m (normal/cramp steering)
	Over boom head	8.33 / 6.87 m (normal/cramp steering)
Engine	Make/model	HINO E13C
	Type	Water cooled, 4 cycle, 6 cylinders, direct injection diesel with turbocharger, intercooler (Anti-pollution conforming to Euromot III)
	Displacement	12.913 liters
	Max. output	330 kW/1,800 min ⁻¹ {449 PS/1,800 rpm}
Max. torque	1,930 Nm/1,300 min ⁻¹ {197 kgf m/1,300 rpm}	
CARRIER MAIN STRUCTURE		
Travel drive	All wheel drive and steering (6 x 6)	
Transmission	Type	HST (Hydrostatic transmission), full-time 6 wheel drive
	No. of speed shift	CVT by HST + High/Low 2-step
Axles	All axles steered and driven by variable displacement hydraulic motors, differential locks for transverse lock. 2-step axle intermediate gear	
Suspension	Hydro-pneumatic suspension (with hydraulic cylinder)	
Steering	Type	Integrated power steering with emergency steering device
	Mode	On-road: 1st and 3rd axle (Steering lock: 2nd axle) Off-road: Clamp mode (all axles), Crab mode (all axles) Manual mode (2nd and 3rd axles)
Brake	Main service brake	Internal expansion drum type with full air booster on all wheels
	Aux. brake	ABS, HST brake
	Parking brake	Spring locked type, acting on wheels of the 2nd and 3rd axles.
Tires (front and rear)	385/95 R25	
Fuel tank	400 liters	

** Over rear/over front/require special equipment

* Over rear/over front/require additional equipment

LIFTING CAPACITIES

MAIN BOOM

• Main boom length: 7.90 - 34.0 m • Outriggers: 6.47 m position • Swing area: 360°

Unit: ton

Boom length (m)	7.90	10.51	13.12	18.34	23.56	28.78	31.39	34.00
Operating radius (m)	2.5	45.00** 40.00*						
	3.0	35.00	24.50	22.50	17.00			
	3.5	33.00	24.50	22.50	17.00			
	4.0	31.00	24.50	22.50	17.00	15.00		
	4.5	28.50	24.50	22.50	17.00	15.00		
	5.0	25.00	24.50	22.50	17.00	15.00	11.40	
	6.0		21.30	19.10	17.00	15.00	11.40	9.45
	7.0		17.80	17.00	16.00	14.00	11.40	9.45
	8.0			15.50	14.70	13.15	11.40	9.45
	9.0			13.05	12.90	11.75	10.60	9.25
	10.0			10.65	10.50	10.80	9.90	8.70
	12.0				7.85	7.80	8.10	7.65
	14.0				5.85	6.10	6.35	6.20
	16.0					4.95	4.95	4.95
	18.0					3.90	4.30	4.15
	20.0					3.15	3.55	3.65
	22.0						2.90	3.05
	24.0						2.40	2.55
26.0							2.10	
28.0							1.75	
30.0								
Boom angle 0°	21.00	14.10	9.15	4.35	2.65	1.85	1.60	1.05

**Over rear/over front/require special equipment

*Over rear/over front/require additional equipment

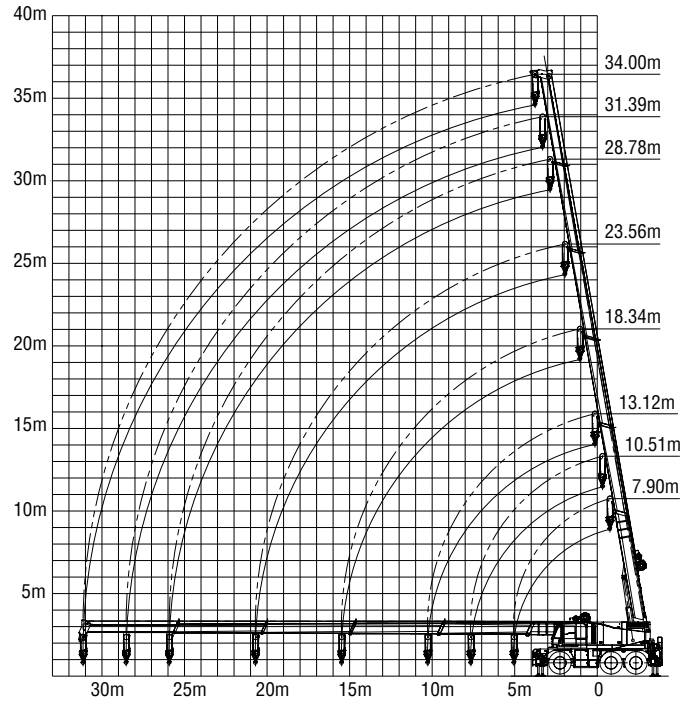

Driveline

Hydrostatic transmission system delivers engine horsepower to the final drive without conventional mechanical-type transmission. And together with our integrated HST brake, offers you advanced mobility and less mechanical trouble.

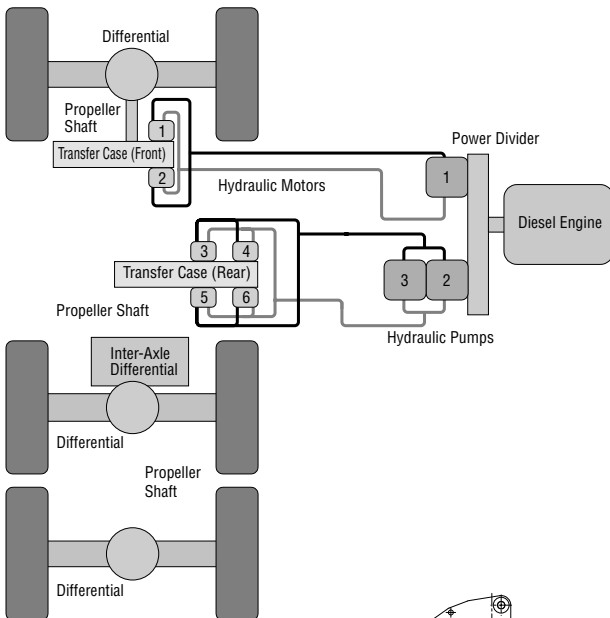

Steering (Unit: mm)

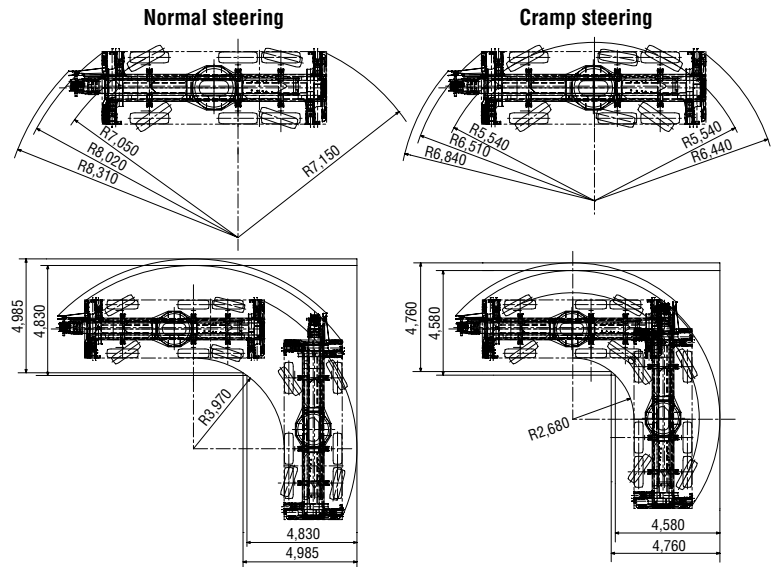

Searcher Hook (Unit: mm)

This 12.5 ton capacity direct hook on our 7.9 m compact boom allows you more access to the confined overhead spaces.

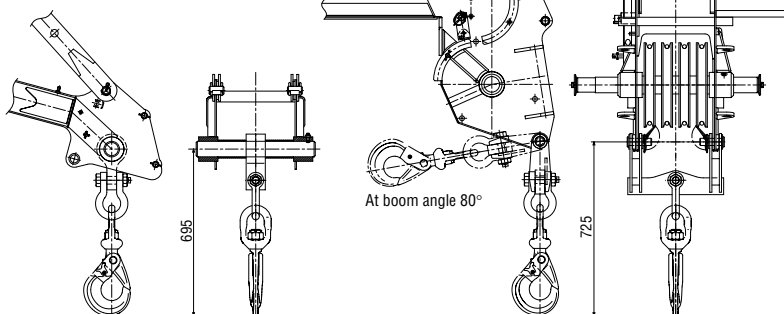

Limit of Hook Lifting (Unit: mm)

Main Boom 25t hook		
Jib offset angle 5° 4t ball hook		
Heavy Duty Jib offset angle 0° 25t hook		
	Boom angle: 0° (Horizontal)	Boom angle: 80° (Max. hoist)

Heavy Duty Jib

The adjustable heavy duty jib will gain further more access, suitable for indoor lifts.

LIFTING CAPACITIES

TWIST JIB

• Boom length: 28.78 - 34.0 m • Jib length: 6.30 - 10.20 m • Outriggers: 6.47 m position • Swing area: 360°

Unit: ton

Operating radius (m)	28.78			34.0		
	5	25	45	5	25	45
8.0	4.00			4.00		
9.0	4.00	3.90		4.00		
10.0	4.00	3.90		4.00	3.90	
11.0	4.00	3.80	1.60	4.00	3.90	
12.0	4.00	3.55	1.60	4.00	3.90	1.60
13.0	3.70	3.30	1.60	4.00	3.70	1.60
14.0	3.45	3.10	1.50	4.00	3.50	1.60
15.0	3.25	2.90	1.40	3.75	3.30	1.60
16.0	3.10	2.75	1.35	3.55	3.10	1.50
17.0	2.95	2.65	1.30	3.35	2.95	1.40
18.0	2.75	2.55	1.20	3.20	2.80	1.35
19.0	2.65	2.40	1.15	3.05	2.70	1.30
20.0	2.35	2.25	1.10	2.90	2.60	1.25
22.0	1.90	1.95	1.00	2.65	2.40	1.15
24.0	1.50	1.50	0.90	2.20	2.15	1.05
26.0	1.15	1.15		1.80	1.85	1.00
28.0	0.80	0.85		1.50	1.60	0.90
30.0				1.15	1.25	
32.0				0.90	0.90	
34.0				0.60	0.65	
No. of part line	1	1	1	1	1	1

Unit: ton

Operating radius (m)	28.78			34.0		
	5	25	45	5	25	45
8.0	3.00					
9.0	3.00			3.00		
10.0	3.00			3.00		
11.0	2.95	2.10		3.00		
12.0	2.90	2.10		3.00		
13.0	2.85	2.10		2.95	2.10	
14.0	2.80	2.10	1.00	2.90	2.10	
15.0	2.75	2.10	1.00	2.85	2.10	1.00
16.0	2.65	2.10	1.00	2.80	2.10	1.00
17.0	2.55	2.05	0.90	2.75	2.10	1.00
18.0	2.45	2.00	0.85	2.70	2.10	1.00
19.0	2.35	1.95	0.80	2.60	2.05	0.90
20.0	2.20	1.90	0.80	2.50	2.00	0.85
22.0	2.00	1.75	0.75	2.30	1.90	0.80
24.0	1.70	1.65	0.70	2.10	1.80	0.75
26.0	1.35	1.50	0.60	1.90	1.70	0.70
28.0	1.10	1.35	0.55	1.60	1.60	0.65
30.0	0.90	1.00		1.30	1.45	0.60
32.0	0.70	0.70		1.10	1.30	0.55
34.0				0.90	1.00	0.50
36.0				0.70	0.70	
No. of part line	1	1	1	1	1	1

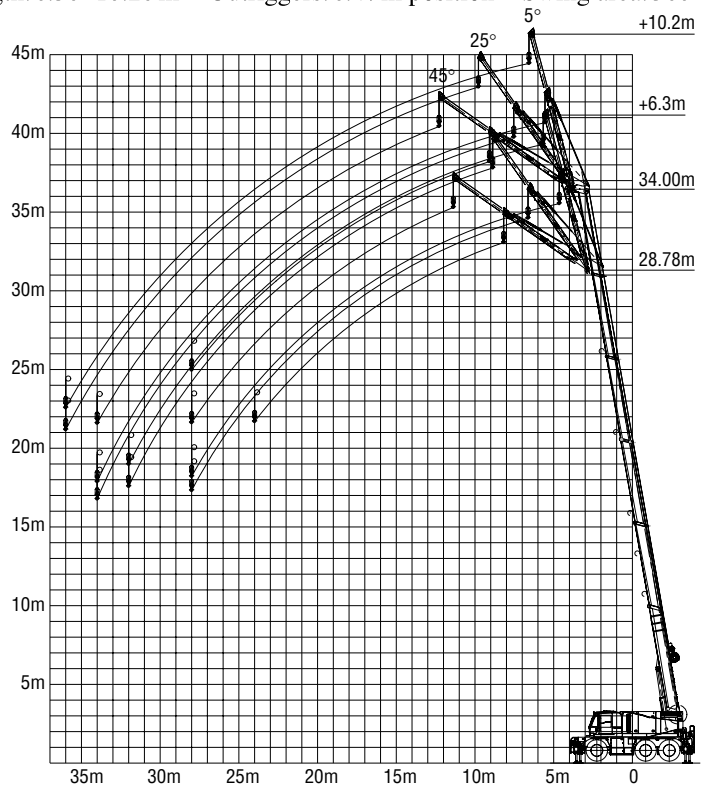

Boom and jib geometry shown does not reflect any deflection of boom and jib. Boom deflection and subsequent radius and boom angle change must be accounted for when at actual operation.

Reference

- RKE450 was designed and manufactured by KOBELCO CRANES CO., LTD. in accordance with the Standard: ASME code B30.5, EN13000:2010.
- The crane is classified as follows (ISO 4301-1, ISO 4301-2).
Class of utilization of cranes = U2
Normal load spectrum factor for cranes = Q2
Group classification of the crane as a whole= A1
- The hoist winch mechanism is classified as follows (ISO 4301-1, ISO 4301-2).
Class of utilization of cranes = T4
State of loading= L1
Group classification of the hoist mechanism as a whole= M3

Furthermore, KOBELCO CRANES CO., LTD. hereby confirms that the stability factor for the RKE450-3.1 EUR is 75% for stationary lifting and 66.6% for pick and carry.

Note

Since the operating radius given in the chart includes allowances for laden boom deflection, the crane must always be operated on the basis of actual operating radius.

Warning

RKE450 is designed for lifting purpose only. Do not use and/or lift attachments which cause vibration or shock. The machine may be damaged.

Lifting capacity

Stationary: Max.

Operating radius 4.5 m

Swing area	360°			
Boom length	m	7.90	10.51	13.12
Lifting capacity	ton	8.00	7.50	7.50

Pick & carry (under 2 km/h): Max.

Operating radius: 3.0 m / Boom length: 7.90-13.12m

Swing area	Over front	Over rear	
Lifting capacity	ton	12.00	15.50

Hook Blocks (Unit: mm)

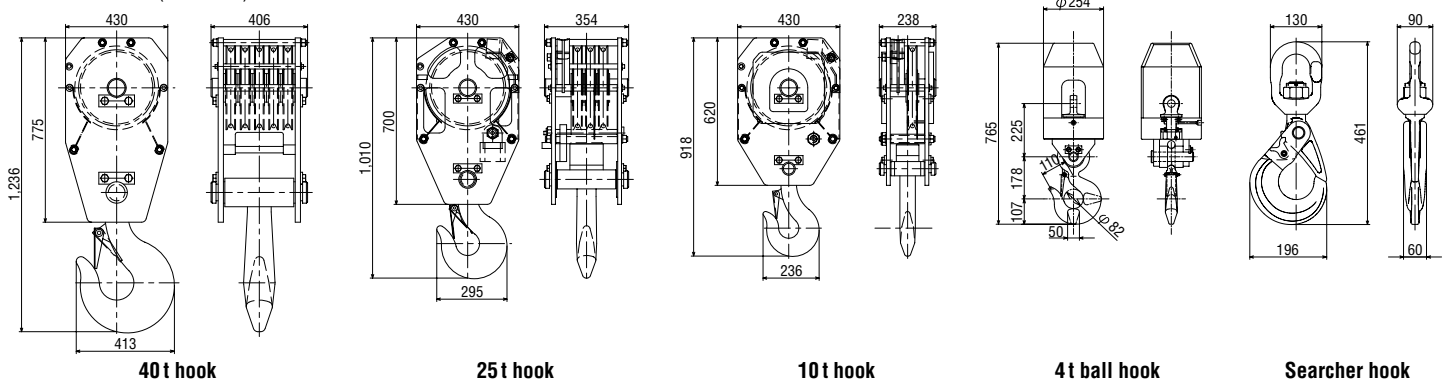

General Dimensions (Unit: mm)

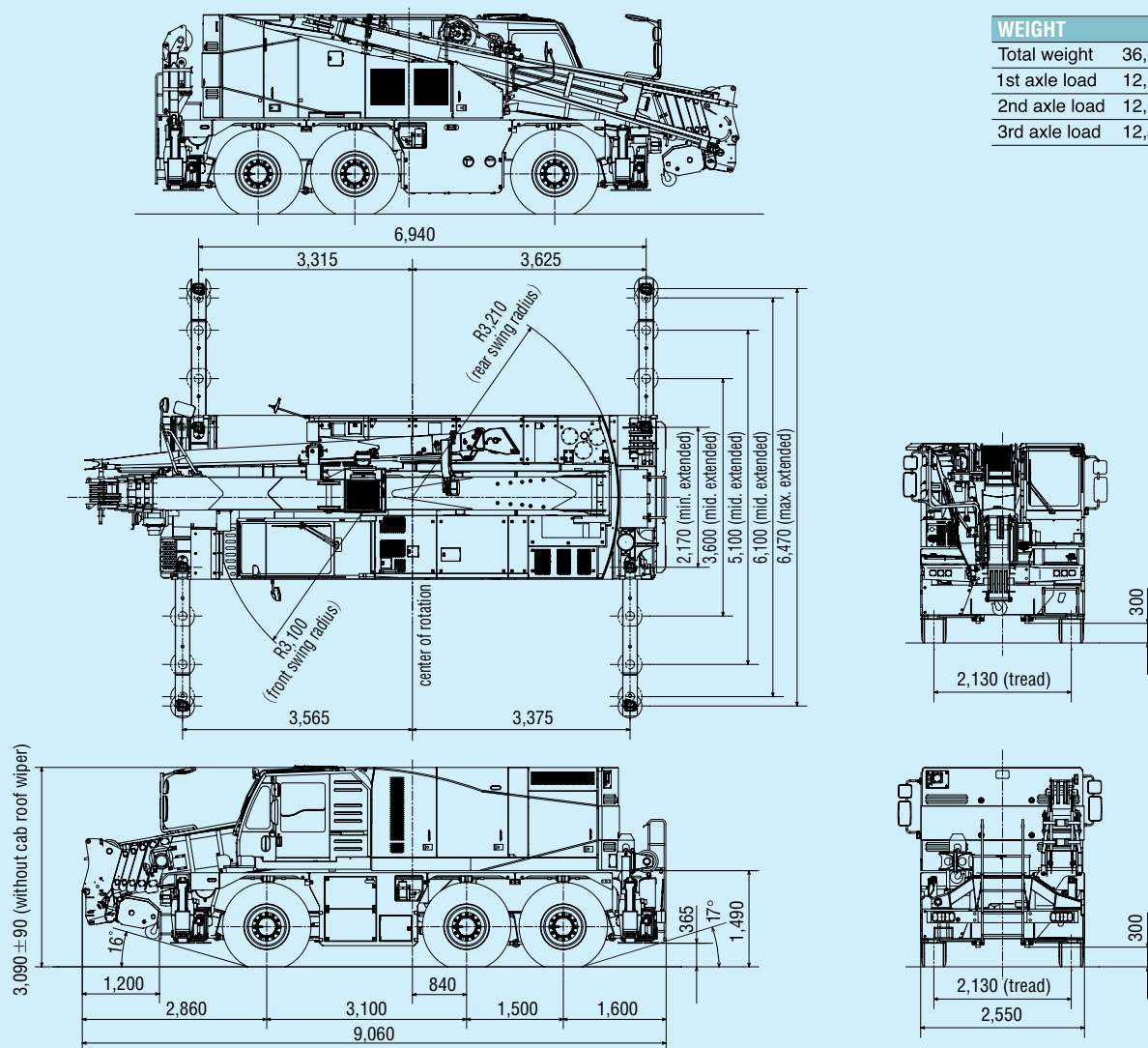

WEIGHT

Total weight	36,000 kg
1st axle load	12,000 kg
2nd axle load	12,000 kg
3rd axle load	12,000 kg

SAFETY DEVICE

Crane System

- Moment limiter (auto-stop)
- Overhoist prevention device (auto-stop)
- Swing automatic stop device
- Working range limit device
- Swing brake
- Swing lock device (front and rear)
- Interceptive lever lock for on and off
- Check & Safety Monitor
- Sling wire lock
- Hoist drum camera
- Overload state record
- Emergency directly connected cable
- Over lowering prevention device (auto-stop)
- Deadman switch

Travel System

- Rear view camera
- Emergency steering pump
- ABS
- Rear steering auto-lock
- Suspension lock device
- Engine overrun warning device
- Reverse sound alarm
- Seat belt

STANDARD EQUIPMENT

- Spotlights
- Hoist drum camera, rear view camera
- Reverse sound alarm
- Hook block 25t (3-sheave)
- Tacho-graph (analog)
- Tools
- Hydraulically retractable side-step for cabin
- Centralized greasing system
- Air conditioner
- Hoist winch
- Foot pedals (swing)
- Outrigger control box (left and right side)

OPTIONAL EQUIPMENT

- Twist jib
- Heavy duty jib
- 4.0t ball, 10.0 t, 25.0t, 40.0 t hook block
- 12.5t searcher hook
- Outrigger spotlight
- Engine pre-heater
- Stainless steel muffler with spark arrester
- Stowage box
- Spare wheel: 385/95 R25
- Spare rim: 385/95 R25
- One-way call
- Radio antenna (on request)
- Fire extinguisher (on request)
- Yellow rotating beacon (on request)
- Boom bumper (on request)

Optional equipment may vary by countries.

Note: This catalog may contain photographs of machines with specifications, attachments and optional equipment not certified for operation in your country. Please consult KOBELCO for those items you may require. Due to our policy of continual product improvements all designs and specifications are subject to change without advance notice.

Copyright by KOBELCO CRANES CO., LTD. No part of this catalog may be reproduced in any manner without notice.



KOBELCO CRANES CO., LTD.

17-1, Higashigotanda 2-chome, Shinagawa-ku, Tokyo 141-8626 JAPAN

Tel: +81-3-5789-2130 Fax: +81-3-5789-3372

URL: <http://www.kobelco-cranes.com/>

Inquiries To:

KOBELCO is the corporate mark used by Kobe Steel on a variety of products and in the names of a number of Kobe Steel Group companies.

Bulletin No.RKE450-3.1-EU1

100301IF Printed in Japan

