

SURFACE GRINDING

FLAT TOOTH QUICK-CHANGE SYSTEM



Flat Tooth Surface Finish

- Interchangeable bits for different grinding applications
- 100% surface coverage with Keystone's flat tooth bit eliminates the need for multiple passes during pavement marking removal
- Increase production by three times when compared to diamond blades and flail teeth
- Minimize surface damage during the removal process. Far less damage seen by the Flat Tooth System than by water blasting equipment and traditional grinding products
- Completely machined bit and block ensures a uniform surface unlike a milled or diamond ground surface pattern
- Carbide and diamond bit options available

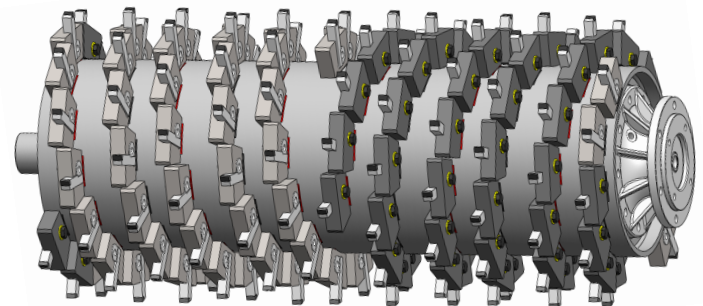
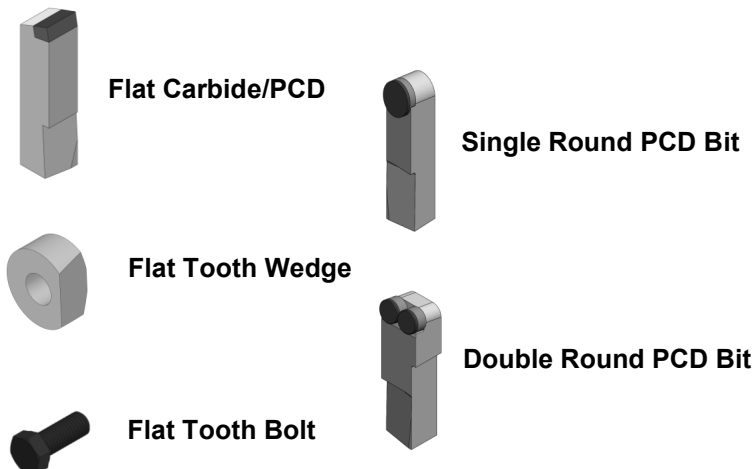
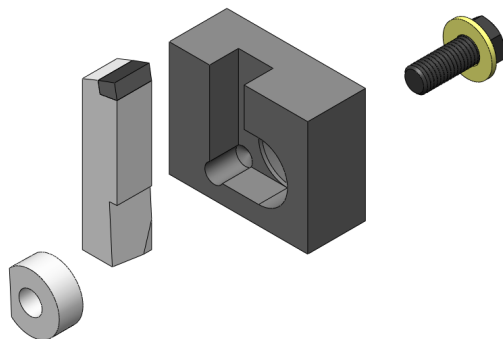

Custom built for any OEM grinding machine