



MINING

Surface Mining



Surface Mining

- **Surface Miner Cutting Systems**
- **Haul Road Maintenance**
- **Wear Protection**

No matter what your application, turn to Kennametal for expert tooling solutions to get your job done efficiently and economically.

Whether you need cutting tools, drums, or wear-protection parts, we have the high-performance products to keep you productive and profitable.





Table of Contents

Haul Road Maintenance	5
KenCast™ Wear Protection	15
Surface Miner Tools	18
Crusher Tooling and Sizing.....	23
Wear Solutions.....	33
Super C™.....	34
Tri-Braze™.....	35
Special Treated Pins.....	36
Prime Arc™.....	37



The foundation for a successful surface mining operation is built on rock-steady reliability and progress. Kennametal, the world's leading tooling and services provider, proudly introduces SOLID, our solution-focused platform that yields new levels of performance and productivity. SOLID-engineered tools deliver in the most challenging conditions. **For unmatched quality, value, innovation, and application expertise, make Kennametal your SOLID choice.**

Kennametal surface mining products are proven to give optimum performance, productivity, and value in the following mining applications:

**Gold | Copper | Diamonds | Coal and Lignite | Iron Ore
Oil Sands | Nickel | Cobalt | Base Metals | Platinum | Granite
Aggregates | Limestone | Phosphate | Potash**



Motor Grader Blades for Haul Road Maintenance

- Heavy-duty scarifier and dual carbide insert blades.
- Far outlast steel or cast-style blades by up to 12:1.
- Eliminate washboard effect and potholes.
- Better road maintenance with fewer passes.
- Easy to install and replace.

Surface Miner Drums

- Custom-designed and built drums to match your specific needs.
- Precision balanced for less machine vibration.
- Available in an array of sizes.
- Tooled with high-performance Kennametal blocks and cutting tools.

KenCast™ Tungsten Carbide Wear Protection

- Tungsten carbide particles metallurgically bonded to air-hardening steel.
- Extremely wear resistant in highly abrasive/impact conditions.
- Significantly extends up-time in high-wear applications.
- Easy to weld and available in many sizes.
- Outlasts overlay products by up to 4:1.



On the Web

Fast. Free. Easy.

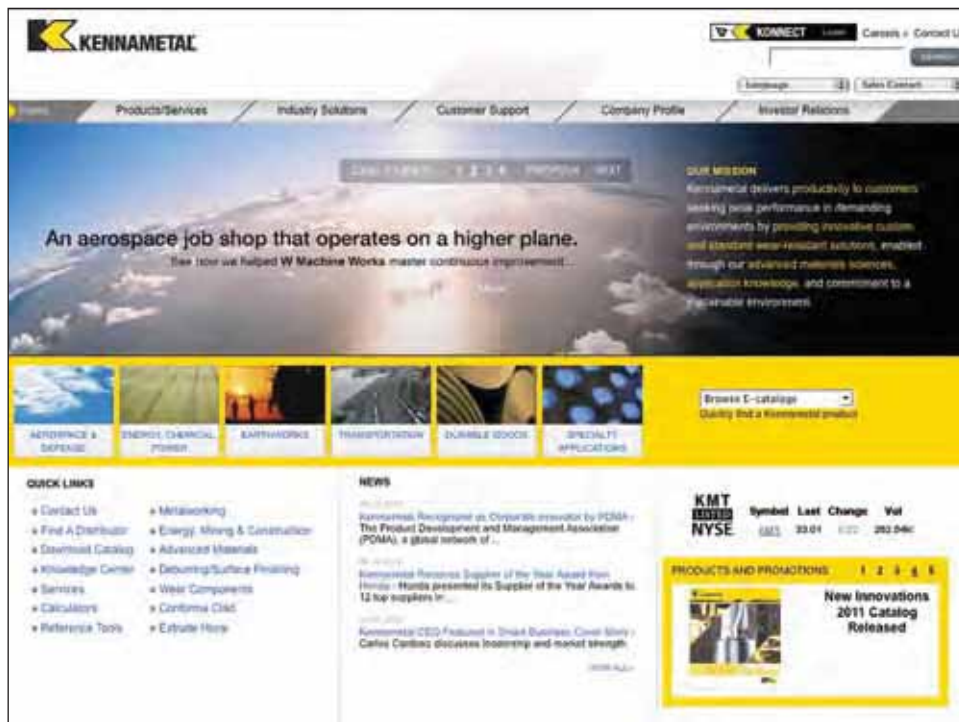

Fast, Free, and Easy Registration

Kennametal Konnect is our custom-crafted, dynamic online sourcing, ordering, and order management tool that features the industry's best products, knowledge, and, ultimately, power. To learn more and register online, visit us at www.kennametal.com.

Convenience

Access our website 24 hours a day, 7 days a week. No need to carry a catalogue when you travel. Just go to www.kennametal.com and you're there.

Timely Updates

Looking for the latest updates on tooling solutions? The measurements and specifications for a series of high-performance metalworking tools? Or do you need to determine the right insert with the best geometry and coating for a specific workpiece material? You'll find this information and more on www.kennametal.com.

e-Catalogue

Our e-Catalogue is driven by images, and our products are broken out exactly as they are in our trusted print catalogues. Check price, availability, and place orders instantly with e-Catalogue. Even download detailed CAD drawings at a product level.

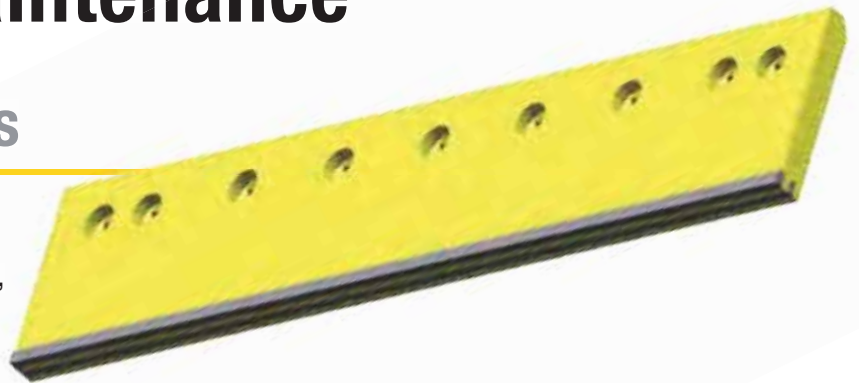

Image by Mike Stobbs

Haul Road Maintenance

Dual Carbide Blades

- Provides maximum wear resistance.
- Features two tungsten carbide inserts, designed for high-abrasion and low-impact applications.
- Outlasts imbedded carbide granule-style blades.
- Offers long-lasting blade life span.
- Reduces costs associated with replacement part inventory, downtime, labor, and overall operations.
- Resists “crowning” and maintains a straighter cutting edge.



Scarifier Blades

- Penetrates hard-packed-, gravel-, and frozen surfaces easily with less down pressure and horsepower.
- Eliminates “washboarding” and pot holes with fewer passes.
- Decreases number of passes necessary to properly maintain road surface.
- Features replaceable, rotating, self-sharpening, solid carbide-tipped cutting tools that wear uniformly and last longer than all-steel blades.
- Allows for quick change of individual tools, increasing machine up-time.

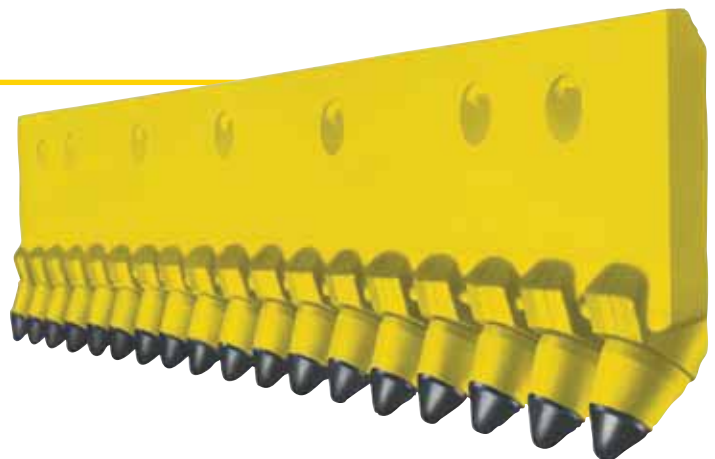

Scarifier Blades

Carbide-Tipped Cutting Tools, Blocks, and Accessories

Engineered to deliver economical, consistent, and reliable performance in a wide range of applications.

Features and Benefits:

- Kennametal's exclusive tungsten carbide-tipped cutting tools outlast all-steel blades.
- Features rotating, self-sharpening cutting tools for more uniform wear and longer tool life.
- Provides exceptional cutting action in demanding, tough surfaces, including hard-packed gravel roads and frozen ground.
- Maintains an even cutting height by enabling cutting tools to be rotated from position to position.
- Reduces machine and operator downtime significantly by enabling operators, in a matter of minutes, to individually change worn cutting tools without using special tools, and without replacing entire blade sections and bolts.

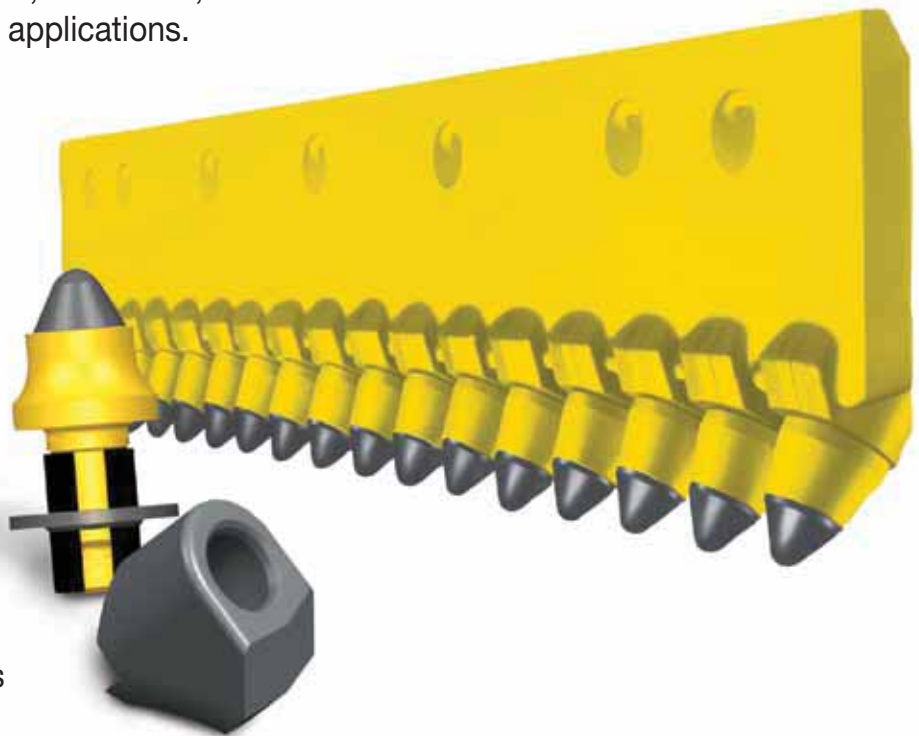

Our Cutting Tools and Blocks are Proven in:

Dirt and Gravel Road Maintenance | Hard-Packed Snow and Ice Removal

Chip and Seal Road Reclamation | Tar Sand Road Reclamation

Spot Asphalt Milling | Spreading Loose Material

Mixing Calcium Chloride, Magnesium Chloride, or other Dust Suppressants



Severe-Duty Scarifier Blades

- Ideal for grading in extreme road conditions and applications. Feature a 152,4mm (6") blade width instead of the 127mm (5") width of standard- and heavy-duty blades for more clearance between the toolholder blocks on the back of the blade and the "frog" of the moldboard. Include extra-heavy welds to reduce block breakout from the blade.
- Our scarifier blades are available in 0,91m (3') and 1,22m (4') lengths, with a variety of depths and widths. Additionally, all Kennametal scarifier blades use a universal bolt hole pattern, so they are compatible with all makes and models of motor graders.
- Using multiple, shorter-length blades to cover the entire moldboard length enables you to easily and safely install the lighter, smaller Kennametal scarifier blades. In addition, should a section become damaged, it is easily and economically replaced. Unlike competitive systems, Kennametal scarifier blades are repairable. Should an individual cutting toolholder (block) become worn or broken, it can be cut out and replaced. With other systems, you would need to replace the entire blade.
- Our blades are easier to use and more versatile than competitive systems. The attack angle of the cutting tools is preset for ease of use and optimum tool rotation and performance. Kennametal systems also accept a wider variety of cutting tool styles including both rotating- and non-rotating-type tools to handle a wider variety of conditions.
- Kennametal's scarifier blade systems are designed so that just the cutting tools get replaced, not the blades. Partially worn cutting tools can be easily repositioned along the moldboard to maintain a straighter edge and achieve balanced cutting tool wear life. A single person can change an entire set of cutting tools in a matter of minutes, even in the field, with no special tools required.

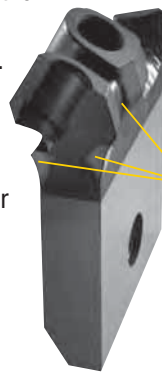

Extra-heavy welds



Weld chamfers around block pockets increase weld strength

Blade Selection Guide for Various Moldboard Lengths

Use the following table to determine the length and number of blades required to outfit your grader with a scarifier system. The length of your moldboard determines how many 0,91m (3') or 1,22m (4') blade sections you will need.

length of moldboard m ft		size and quantity of scarifier blade sections required for (1) moldboard assembly		number of conicals required
		0,91m (3') sections	1,22m (4') sections	
3,66	12	0	3	72
3,96	13	3	1	78
4,27	14	2	2	84
4,88	16	0	4	96

NOTE: Kennametal recommends the use of Grade 8, Number 3 head-plow bolts and nuts when installing blades.

Scarifier Blade Sizes • Ordering Information

Upon determining the length and number of scarifier blades required, use the following specifications table to determine the specific style of scarifier blade — standard-, heavy-, and/or severe-duty that you need. Also use this chart to determine the number of cutting tools required.

order number	blade size		bolt size		number of conicals required	kg	lbs
	mm	in	mm	in			
1083322	31,75 x 152,4 x 914,4	1-1/4 x 6 x 36	15,88	5/8	18	36,7	81
1083323	31,75 x 152,4 x 1219,2	1-1/4 x 6 x 48	15,88	5/8	24	49,4	109
1013086	31,75 x 152,4 x 914,4	1-1/4 x 6 x 36	19,05	3/4	18	36,7	81
1013087	31,75 x 152,4 x 1219,2	1-1/4 x 6 x 48	19,05	3/4	24	49,4	109

NOTE: The above blades feature conical toolholder blocks positioned on 50,8mm (2") centers. All blades are punched in a heavy-duty standard highway punch pattern, meaning the last two holes of each blade are on 76,2mm (3") centers with the rest of the holes on 152,4mm (6") centers. Kennametal scarifier blades can be used in combination to fit virtually every make and model of motor grader manufactured.

End Protectors

Dimensions below are shown in millimeters and (inches).

Kennametal recommends the use of our carbide end protectors for scarifier blades. The heavy-duty design and tough steel supports of our end protectors resist breakage and bending in any road application. Our end protectors feature KenCast™ composite material that combines the wear resistance of Kennametal's exclusive tungsten carbide with the ductility of air-hardening steel.

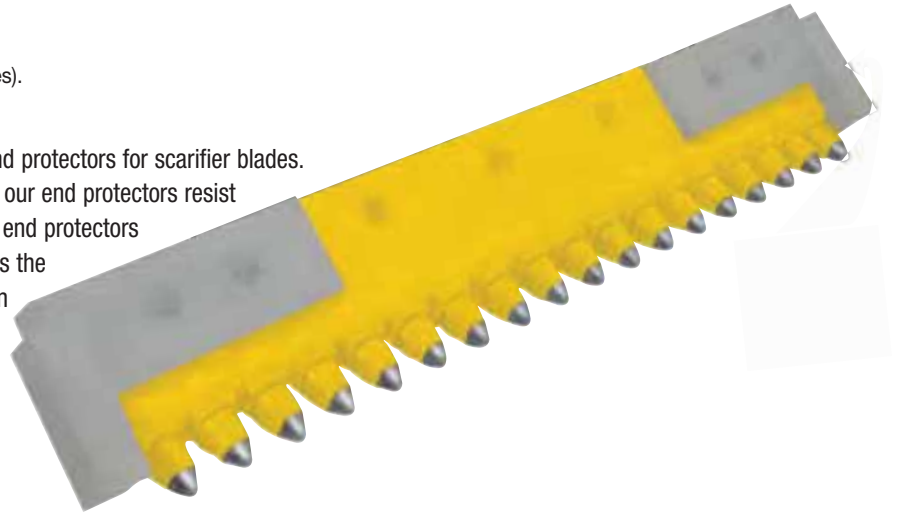

For Severe-Duty Blades

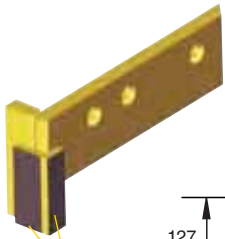

KenCast protection

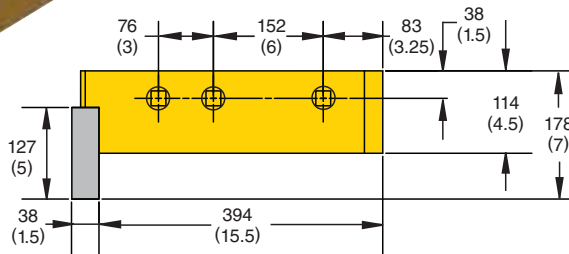

■ End Protectors • Ordering Information

order number	catalog number	bolt design	description	bolt diameter		approximate unit weight	
				mm	in	kg	lbs
for severe-duty blades:							
1821674	KCWB-0442	3-bolt design for severe-duty systems	right-hand end protector	19	.75	11	25
1821679	KCWB-0443	3-bolt design for severe-duty systems	left-hand end protector	19	.75	11	25



Dimensions below are shown in millimeters and (inches).

C87WFRKCSB

- Superior wear and rotation.
- Washer keeps out debris and improves rotation for longer bit life and less block wear.
- New full-sleeve retainer protects the inside of the bore to prevent uneven wear.
- Washer precompresses the retainer which makes it easier to install.
- Retainer grips tighter to prevent bit loss.

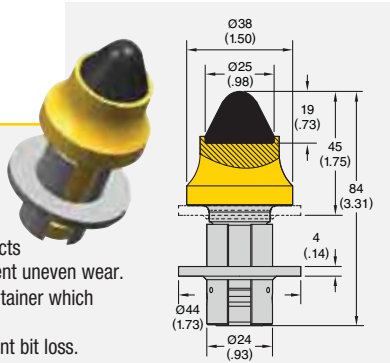

order number	catalog number	pieces per container	kg	lbs
2041786	C87WFRKCSB	50	,38	.841

C858KCSB

- Longest wearing carbide tip available.
- For use on all types of road surfaces.
- Specially designed carbide tip for extra-long tool life and added steel-wash protection.
- 37mm (1.45") diameter cutting tool shoulder protects block face from excessive wear.

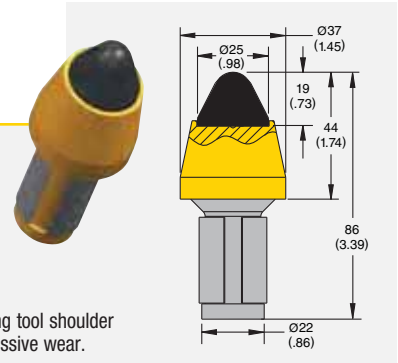

order number	catalog number	pieces per container	kg	lbs
1010880	C858KCSB	50	,38	.840

C87KCSBSR

- Same design as C858KCSB, with added "barbed" short retainer for improved cutting tool retention.

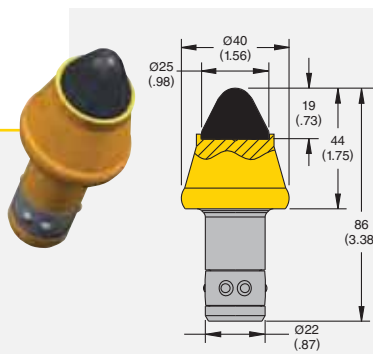

order number	catalog number	pieces per container	kg	lbs
1010937	C87KCSBSR	50	,37	.815

C87DSSR

- Same tip design as C387DS, but shank features "barbed" short retainer for improved retention in block.
- Larger steel body provides longer wear life.

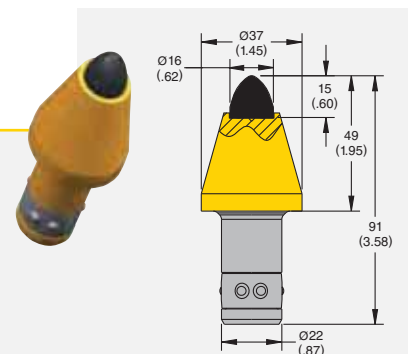

order number	catalog number	pieces per container	kg	lbs
1010935	C87DSSR	50	,35	.772

C855KCSB

- Designed for maximum wear life and durability (like C858KCSB), but made to fit most blade systems.
- Longer gage length for reduced wear on blades and blocks.
- Ideal for general-duty and heavy-impact applications.

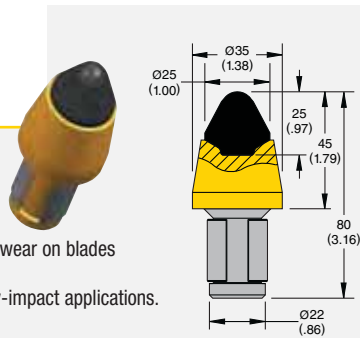

order number	catalog number	pieces per container	kg	lbs
1855704	C855KCSB	50	,35	.780

C100 24.43SB

- Specially designed and manufactured for use in competitive "mining duty" systems (This tool does NOT fit Kennametal blade systems).
- Contains more carbide than similar competitive designs.

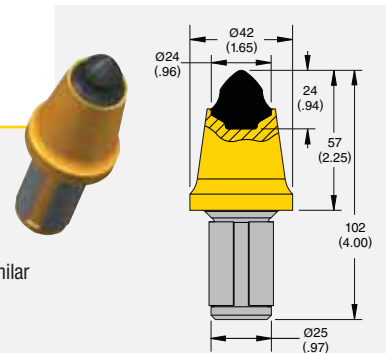

order number	catalog number	pieces per container	kg	lbs
1847237	C100 24.43SB	25	,54	1.180

C855LR

- Sharp carbide tip.
- Fits Kennametal and competitive blade systems.

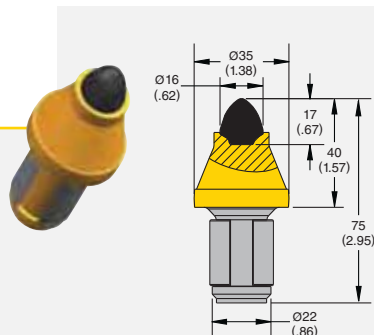

order number	catalog number	pieces per container	kg	lbs
1011001	C855LR	50	,25	.544

C387BF

- Sharp pointed tip for easy penetration of hard surfaces.
- Excellent in soft to medium-hard abrasive conditions.
- Specially designed flange protects block face from excessive wear.
- Ideal for removing high spots and washboard effect on asphalt-paved roads.

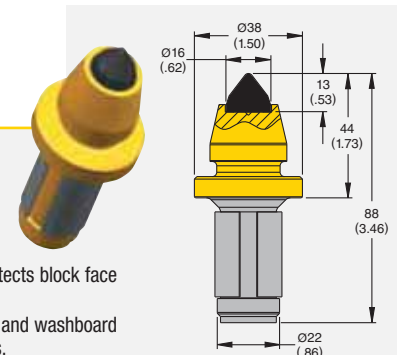

order number	catalog number	pieces per container	kg	lbs
1010817	C387BF	50	,30	.659

Surface Mining • Haul Road Maintenance

Dimensions below are shown in millimeters and (inches).

■ **C855HDX-4**

- Economy-sized carbide tip.
- Improved with 30% stronger braze.
- Additional steel in body style for added strength and wear life.
- Fits most blade systems.

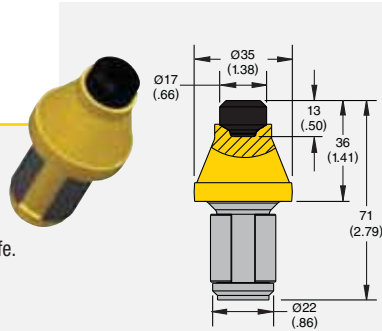

order number	catalog number	pieces per container	kg	lbs
3386038	C855HDX-4	50	,26	.570

■ **C87HDRP**

- Economy-sized carbide tip.
- Washer keeps out debris and improves rotation for longer bit life and less block wear.
- Full sleeve retainer protects inside of the bore to prevent uneven wear.
- Retainer grips tighter to prevent bit loss.
- Washer precompresses the retainer for easier installation.

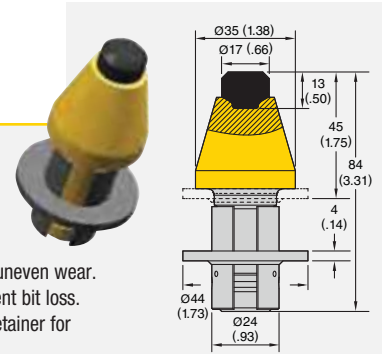

order number	catalog number	pieces per container	kg	lbs
3837213	C87HDRP	50	,34	.756

■ **C855HD**

- Larger carbide tip.
- Improved with 30% stronger braze.
- Blunt-nose tip style.
- Fits most blade systems.

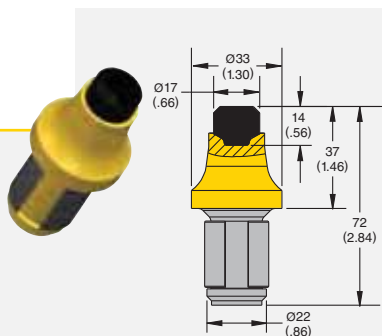

order number	catalog number	pieces per container	kg	lbs
1011208	C855HD	50	,24	.540

■ **C855HDX**

- Larger carbide tip.
- Improved with 30% stronger braze.
- Same body style as C855HD, but with added steel for increased strength and wear life.
- Fits most blade systems.

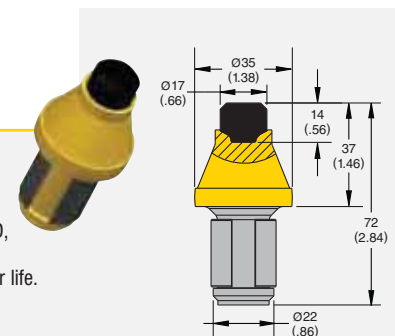

order number	catalog number	pieces per container	kg	lbs
1011206	C855HDX	50	,27	.597

■ **C387DS**

- Sharper carbide tip for increased penetration.
- Large carbide tip for long tool life.
- Specially designed flange protects block from excessive wear.
- Puller groove for easier tool extraction from front side of blade.

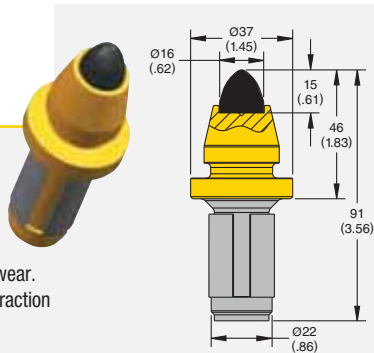

order number	catalog number	pieces per container	kg	lbs
1010906	C387DS	50	,31	.674

■ **C87GB Block**

- Replacement toolholder for Kennametal blade systems.
- Easily welded with a 7018 or 8018 low-hydrogen rod, with no pre-heating required.

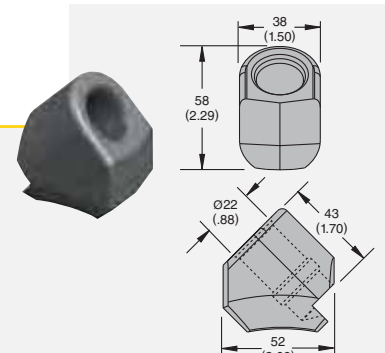

order number	catalog number	pieces per container	kg	lbs
1012234	C87GB Block	30	,43	.950

Surface Mining • Haul Road Maintenance

Extraction Tools

Make cutting tool changes easier and safer.

Dimensions below are shown in millimeters and (inches).

KHP2 Hammer Punch

- For removing cutting tools from blocks.
- Hardened tip for longer life; used with a hammer.
- Plastic hand protector for added safety.

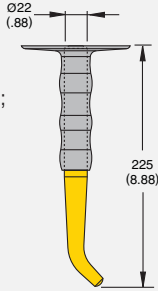

order number	catalog number
1012247	KHP2 KMTL PUNCH

KAHP1 Air-Hammer Punch

- For removing cutting tools from blocks.
- Hardened tip for durability.
- Fits all light-duty, air-hammer guns that have a 10mm (.375") chuck.

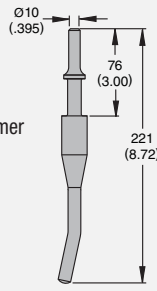

order number	catalog number
1012245	KAHP 1 AIR HAMMER PUNCH

KAHP 1D Air-Hammer Punch

- For removing cutting tools from blocks.
- Hardened tip for durability.
- Fits all heavy-duty, air-hammer guns that have a 13mm (.500") chuck.

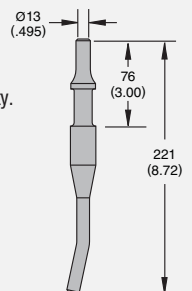

order number	catalog number
1012246	KAHP 1HD AIRHAMMER PUNCH

Retainers

LR87

- Replacement retainer for use with C387DS, AR15087, C387BF, KCWB-0448, and C87BF cutting tools.



order number	catalog number
1011935	LR87 RETAINER

C87SR

- Replacement retainer for use with C87KCSBSR and C87DSSR cutting tools.



order number	catalog number
1012363	C87SR RETAINER

LR858

- Replacement retainer for use with C858KCSB.



order number	catalog number
1012089	LR858 RETAINER

C100SB

- Replacement retainer for use with C100 24.43SB cutting tools.



order number	catalog number
1851733	C100SB RETAINER

RPR07 Retainer

- Replacement retainer for C87WFRKCSB.



order number	catalog number
1990418	RPR07

LR85

- Replacement retainer for use with C855DS, C855HD, C855HDX, C855LR, C855KCSB, and C855HDX-4 cutting tools.



order number	catalog number
1012117	LR85 RETAINER

SR Washer 44MM

- Replacement washer for C87WFRKCSB.



order number	catalog number
1992068	SR WASHER 44MM

Guidelines for Proper Use of Scarifier Blades

These guidelines are designed to help maximize Kennametal Scarifier Blade performance:

1. Kennametal recommends using only Grade 8, No. 3 head plow bolts and matching Grade 8 heavy hex nuts to install our scarifier blades.
2. Position and operate blades at a 90° angle to the road surface so cutting tools are at the proper cutting angle (see drawing).
3. Carbide-tipped cutting tools should be used to penetrate a depth no greater than 25mm (1.00").
4. Inspect the blade and cutting tools daily. Replace lost, worn, or broken cutting tools immediately.
5. Kennametal carbide cutting tools are self-rotating and self-sharpening. Inspect cutting tools daily by turning them with your hand to ensure they are rotating properly. Cutting tools that do not turn can usually be freed by several light taps with a soft-headed hammer. Clean cutting tool and block assemblies with a solvent cleaner when necessary to ensure proper rotation of the cutting tool. Do not use oil for this purpose. Oil will cause dirt to adhere to the cutting tool, preventing proper rotation.
6. Do not use these blades to remove large rocks or boulders. These blades are intended for use in scarifying roads to return them to their original aggregate condition. Using Kennametal scarifier blades to remove large rocks or boulders terminates and voids all warranties and obligations from Kennametal as manufacturer and supplier.
7. When transporting scarifier blades fitted with long-retainer cutting tools, be sure to roll the moldboard backward so the blade is horizontal and the cutting tools are pointed upward. This will prevent the cutting tools from vibrating out of the blade while in transit. This procedure is not necessary when using short-retainer cutting tools in the blade.
8. The travel speed of the grader may affect the performance of the blade. When working in heavy-impact applications, use a lower speed (such as second gear). This will reduce the risk of cutting tool breakage or blade damage.
9. "Backdragging" is not recommended. This procedure increases the risk of breakage or loss of cutting tools and puts unnecessary stress on the blade, bolts, and moldboard.
10. Use Kennametal carbide end protectors in applications that subject the side of the blade to wear (like ditching). End protectors do not interfere with penetration and protect the ends of the blade from excessive wear.

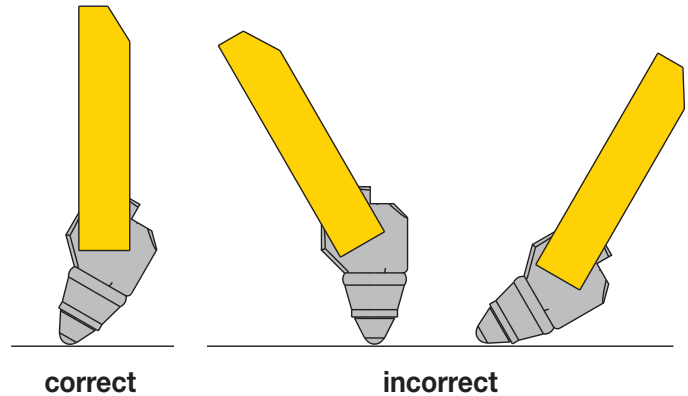

To replace a worn or broken block:

1. Cut out the broken block, if necessary, and clean the recess to remove rust and loose material.
2. Align the new block at the appropriate attack angle and tack weld into position.
3. Weld around the upper part of the block first on the front and back side of the blade.
4. Use Airco 7018M or equivalent welding material.
5. Use a welding rod (stick) with a maximum 3mm (.125") diameter or a welding wire with a maximum 1mm (.052") diameter.
6. Angle the weld gun or rod to run a root pass along the block base where it meets the 13mm (.500") wide steel "tongue" between the blocks. Do not weld back and forth between the blocks. Run one pass on each side of the block in opposite directions to weld it to the blade.

Dual Carbide Blades

Dual Carbide Blades with an Improved Braze and a Steel Body with Increased Wear-Resistance.

Engineered specifically to reduce costs associated with:

- Replacement part inventory.
- Downtime.
- Labor.
- Overall operations.

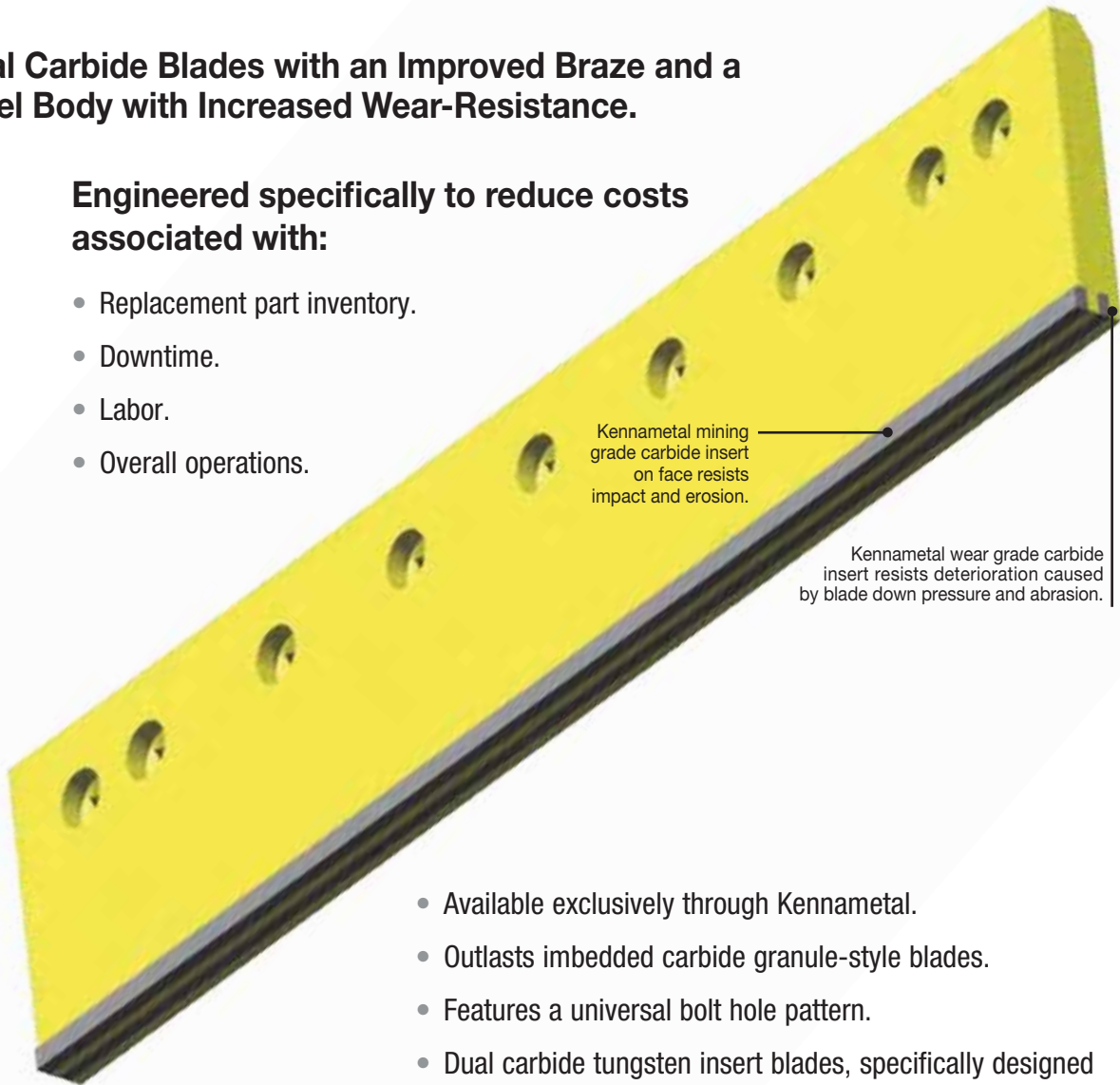

Kennametal mining grade carbide insert on face resists impact and erosion.

Kennametal wear grade carbide insert resists deterioration caused by blade down pressure and abrasion.

- Available exclusively through Kennametal.
- Outlasts imbedded carbide granule-style blades.
- Features a universal bolt hole pattern.
- Dual carbide tungsten insert blades, specifically designed for high-abrasion and low-impact applications to stay straight; maintain a sharp, clean edge; and stop crowning:
 - First insert is formulated with our proprietary macrocrystalline carbide grade, for toughness and impact resistance, and mounts on the front of blade.
 - Second insert is made from a wear-resistant carbide grade and mounts directly behind the first insert to resist wear caused by blade down pressure and abrasion.
- Backed by a comprehensive warranty program.

■ **Dual Carbide Insert Blade for C24H and Cat 16 G, H, and M Motor Graders**

Dimensions below are shown in millimeters and (inches).

order number	bolt size		blade size		kg	lbs
	mm	in	mm	in		
2421387	25,40	1	38,1 x 254 x 1219,2	1-1/2 x 10 x 48	93	205
2607102	19,05	3/4	25,4 x 203.2 x 1219,2	1 x 8 x 48	79,4	175

■ **Dual Carbide Blade Sizes • Ordering Information**
(Blades Beveled at Top to Fit Grader Moldboard)

order number	bolt diameter		thickness		width		length		kg	lbs
	mm	in	mm	in	mm	in	mm	in		
1011871	15,88	5/8	22,23	7/8	127	5	610	24	14,5	32
1011872	15,88	5/8	22,23	7/8	127	5	914	36	21,8	48
1011875	15,88	5/8	22,23	7/8	127	5	1219	48	28,6	63
1011879	19,05	3/4	22,23	7/8	127	5	914	36	21,8	48
1011877	19,05	3/4	22,23	7/8	127	5	1219	48	28,6	63

NOTE: When ordering, please provide the order number. Also specify hole size and moldboard length.

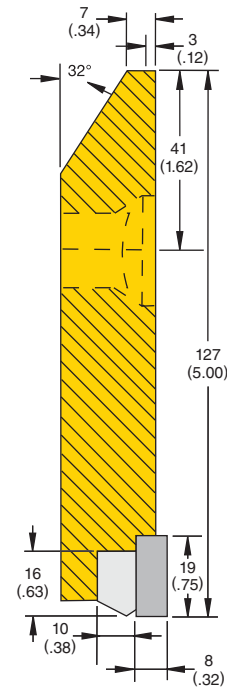

Surface Mining • Haul Road Maintenance



KenCast™ Wear Protection

KenCast is a unique wear protection material that can significantly increase tool life — and productivity.



- Specifically engineered to guard against premature and costly wear on your surface mining equipment.
- Tungsten carbide particles are metallurgically bonded to air-hardening steel to create this highly abrasion- and impact-resistant composite.
- Available in standard sizes or custom-made to fit your equipment.
- Easy to weld.

Proven Performance in:

Bucket Lips | Drill Stabilizers | Grouser Bars
Shovel Protection | Dozer Blade Wear Areas

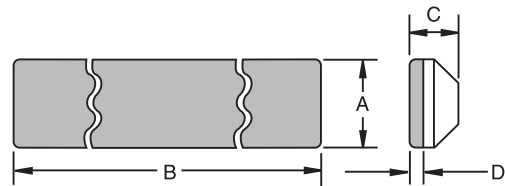

■ Standard Bars with Weld Bevel

order number	catalog number	A		B		C		D	
		mm	in	mm	in	mm	in	mm	in
1094287	KCWB-0367	25,4	1	50,8	2	12,7	1/2	3,18	1/8
1012536	KCWB-0246	25,4	1	50,8	2	12,7	1/2	6,35	1/4
1624932	KCWB-0414	15,88	5/8	133,35	5-1/4	15,88	5/8	6,35	1/4
1012544	KCWB-0254	15,88	5/8	50,8	2	19,05	3/4	6,35	1/4
1012504	KCWB-0201	15,88	5/8	101,6	4	19,05	3/4	6,35	1/4
1012545	KCWB-0255	19,05	3/4	50,8	2	19,05	3/4	6,35	1/4
1155344	KCWB-0378	19,05	3/4	127	5	19,05	3/4	6,35	1/4
1012633	KCWB-0055-20	25,4	1	50,8	2	19,05	3/4	6,35	1/4
1012634	KCWB-0055-30	25,4	1	76,2	3	19,05	3/4	6,35	1/4
1012635	KCWB-0055-35	25,4	1	88,9	3-1/2	19,05	3/4	6,35	1/4
1012636	KCWB-0055-40	25,4	1	101,6	4	19,05	3/4	6,35	1/4
1012637	KCWB-0055-50	25,4	1	127	5	19,05	3/4	6,35	1/4
1012638	KCWB-0055-60	25,4	1	152,4	6	19,05	3/4	6,35	1/4
1012639	KCWB-0055-80	25,4	1	203,2	8	19,05	3/4	6,35	1/4
1012447	KCWB-0096	25,4	1	254	10	19,05	3/4	6,35	1/4
1012448	KCWB-0097	25,4	1	304,8	12	19,05	3/4	6,35	1/4
1083967	KCWB-0362	38,1	1-1/2	50,8	2	19,05	3/4	6,35	1/4
1012436	KCWB-0067	38,1	1-1/2	127	5	19,05	3/4	6,35	1/4
1012640	KCWB-0056-20	50,8	2	50,8	2	19,05	3/4	6,35	1/4
1012641	KCWB-0056-35	50,8	2	88,9	3-1/2	19,05	3/4	6,35	1/4
1012642	KCWB-0056-40	50,8	2	101,6	4	19,05	3/4	6,35	1/4
1012643	KCWB-0056-60	50,8	2	152,4	6	19,05	3/4	6,35	1/4
1012644	KCWB-0056-80	50,8	2	203,2	8	19,05	3/4	6,35	1/4
1012628	KCWB-0342	50,8	2	254	10	19,05	3/4	6,35	1/4

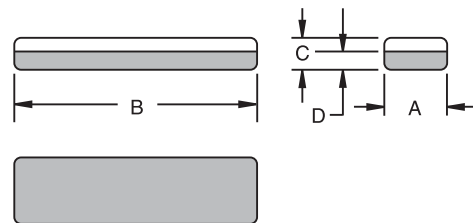

■ Standard Wear Bars

order number	catalog number	A		B		C		D	
		mm	in	mm	in	mm	in	mm	in
1012566	KDWB-0277	25,4	1	203,2	8	6,35	1/4	3,18	1/8
1012515	KCWB-0216	38,1	1-1/2	152,4	6	6,35	1/4	3,18	1/8
1012512	KCWB-0210	50,8	2	50,8	2	6,35	1/4	3,18	1/8
1012567	KCWB-0278	50,8	2	203,2	8	6,35	1/4	3,18	1/8
1012532	KCWB-0241	76,2	3	152,4	6	6,35	1/4	3,18	1/8
1012461	KCWB-0132	12,7	1/2	101,6	4	12,7	1/2	6,35	1/4
1012586	KCWB-0300	19,05	3/4	101,6	4	12,7	1/2	6,35	1/4
1174410	KCWB-0301	25,4	1	76,2	3	12,7	1/2	6,35	1/4
1012454	KCWB-0114	25,4	1	101,6	4	12,7	1/2	6,35	1/4
1012494	KCWB-0188	38,1	1-1/2	127	5	12,7	1/2	6,35	1/4
1012445	KCWB-0092	50,8	2	76,2	3	12,7	1/2	6,35	1/4
1012614	KCWB-0329	50,8	2	133,35	5-1/4	12,7	1/2	6,35	1/4
1012444	KCWB-0091	50,8	2	152,4	6	12,7	1/2	6,35	1/4
1012450	KCWB-0100	50,8	2	203,2	8	12,7	1/2	6,35	1/4
1012446	KCWB-0095	50,8	2	400,05	15-3/4	12,7	1/2	6,35	1/4
1012435	KCWB-0065	76,2	3	101,6	4	12,7	1/2	6,35	1/4
1012539	KCWB-0249	76,2	3	152,4	6	12,7	1/2	6,35	1/4
1714701	KCWB-0302	25,4	1	114,3	4-1/2	15,88	5/8	6,35	1/4
1012442	KCWB-0083	12,7	1/2	69,85	2-3/4	19,05	3/4	6,35	1/4
1012492	KCWB-0186	38,1	1-1/2	254	10	19,05	3/4	6,35	1/4
1012575	KCWB-0286	127	5	304,8	12	19,05	3/4	6,35	1/4
1714704	KCWB-0010	177,8	7	330,2	13	50,8	2	6,35	1/4

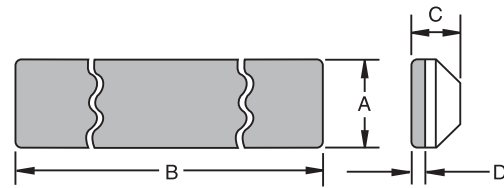
Standard Bars with Weld Bevel

order number	catalog number	A		B		C		D	
		mm	in	mm	in	mm	in	mm	in
1324494	KCWB-0384	63,5	2-1/2	203,2	8	19,05	3/4	6,35	1/4
1324495	KCWB-0395	63,5	2-1/2	304,8	12	19,05	3/4	6,35	1/4
1012437	KCWB-0073	66,68	2-5/8	133,35	5-1/4	19,05	3/4	6,35	1/4
1012645	KCWB-0057-20	76,2	3	50,8	2	19,05	3/4	6,35	1/4
1012646	KCWB-0057-35	76,2	3	88,9	3-1/2	19,05	3/4	6,35	1/4
1012647	KCWB-0057-40	76,2	3	101,6	4	19,05	3/4	6,35	1/4
1012648	KCWB-0057-60	76,2	3	152,4	6	19,05	3/4	6,35	1/4
1012649	KCWB-0057-80	76,2	3	203,2	8	19,05	3/4	6,35	1/4
1012622	KCWB-0337	101,6	4	330,2	13	19,05	3/4	6,35	1/4
1012618	KCWB-0333	152,4	6	254	10	19,05	3/4	6,35	1/4
1080018	KCWB-0345	44,45	1-3/4	228,6	9	22,23	7/8	6,35	1/4
1012422	KCWB-0019	50,8	2	228,6	9	22,23	7/8	6,35	1/4
1308317	KCWB-0389	15,88	5/8	76,2	3	25,4	1	6,35	1/4
1502226	KCWB-0399	19,05	3/4	203,2	8	25,4	1	6,35	1/4
1012443	KCWB-0084	25,4	1	101,6	4	25,4	1	6,35	1/4
1012423	KCWB-0022	50,8	2	254	10	25,4	1	6,35	1/4
1012452	KCWB-0105	50,8	2	304,8	12	25,4	1	6,35	1/4
1012449	KCWB-0098	127	5	203,2	8	25,4	1	6,35	1/4
1085557	KCWB-0094	222,25	8-3/4	273,05	10-3/4	25,4	1	6,35	1/4
1012573	KCWB-0284	50,8	2	330,2	13	31,75	1-1/4	6,35	1/4
1919347	KCWB-0471	38,1	1-1/2	152,4	6	25,4	1	6,35 + 101,6	1/4 + 4
2036144	KCWB-0496	152,4	6	152,4	6	31,75	1-1/4	6,35 + 101,6	1/4 + 4

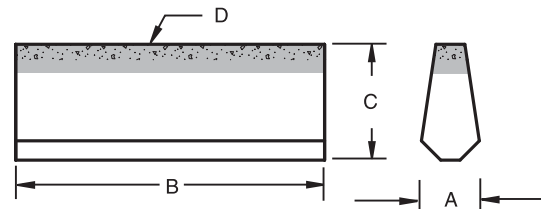
Standard Bars with Weld Bevel

order number	catalog number	A		B		C		D	
		mm	in	mm	in	mm	in	mm	in
1012598	KCWB0313	20,64	13/16	152,4	6	44,45	1-3/4	6,35 + 101,6	1/4 + 4
2259012	KCWB0515	19,05	3/4	101,6	4	38,1	1-1/2	negative 101,6 + 152,4	negative 4 + 6

Surface Mining • KenCast Wear Protection



Surface Miner Tools

No matter the cutting conditions, equipment, or budget, we have just the tools you need.

Gold

Choose from **our very best tools** to save time and money. Simply, these products — with their exceptionally durable bodies with our proprietary hardness (**throughout the entire head**) process — deliver ultra-high performance over their lifetime versus any existing tools. That results in fewer teeth required, less downtime, and greatly reduced operating costs — helping you become more productive and profitable. In addition, these tools incorporate our latest tip designs for maximum penetration and service. Plus, these tools have extra-wide collars for unmatched block protection.

- Unique body hardness process provides high-performance output over the life of the tool.
- Extra-wide collars safeguard blocks.
- Latest tip designs for ultimate penetration.

Silver

When your work calls for tools with **something beyond ordinary** performance, select from this series. Our unique carbide-tip grades and designs, in conjunction with Kennametal's exceptional retention methods, yield superior results, in even the most challenging applications.

- Extra-wide collars safeguard blocks.
- Latest tip designs for ultimate penetration.

Bronze

Kennametal's Classic tools. Time-tested and proven in the field. For your everyday cutting requirements, no comparable products can provide the same efficiency.

- Latest tip designs for ultimate penetration.

Tool Selection Guide

■ Select the right tool for your application

- Gold** (best)
- Silver** (better)
- Bronze** (good)

	catalog number	order number	shank		insert diameter		cutting width							
			mm	in	mm	in	<2500mm (98.43")				>2500mm (98.43")			
			cutting conditions											
						light (0-20 MPa)	medium (20-50 MPa)	heavy (50-80 MPa)	severe (>80 MPa)	light (0-20 MPa)	medium (20-50 MPa)	heavy (50-80 MPa)	severe (>80 MPa)	
TSCX/KSMX Series	TS19C X	4066765	38/30	1.5/1.18	17,5	0.69	■				■			
	TS31C X	4066872	38/30	1.5/1.18	19	0.75		■			■			
	TS32C X	4066821	38/30	1.5/1.18	22	0.87			■			■		
	TS30C X	4050638	38/30	1.5/1.18	25	0.98				■			■	
	KSM42 LW1	Made to Order	42	1.65	17,5	0.69	■				■			
	KSM42 LW2	Made to Order	42	1.65	19	0.75		■				■		
	KSM42 LW3	Made to Order	42	1.65	22	0.87			■				■	
	KSM42 LW4	Made to Order	42	1.65	25	0.98				■				■
TS/KSM Series	TS19	1750422	38/30	1.5/1.18	17,5	0.69	■				■			
	TS31	2602450	38/30	1.5/1.18	19	0.75		■			■			
	TS32	2602451	38/30	1.5/1.18	22	0.87			■			■		
	TS30	2458404	38/30	1.5/1.18	25	0.98				■			■	
	KSM42 S1	Made to Order	42	1.65	17,5	0.69	■				■			
	KSM42 S2	Made to Order	42	1.65	19	0.75		■				■		
	KSM42 S3	Made to Order	42	1.65	22	0.87			■				■	
	KSM42 S4	Made to Order	42	1.65	25	0.98				■				■
U Series	KSM42 E1	Made to Order	42	1.65	17,5	0.69	■				■			
	KSM42 E2	Made to Order	42	1.65	19	0.75		■				■		
	KSM42 E3	Made to Order	42	1.65	22	0.87			■				■	
	KSM42 E4	Made to Order	42	1.65	25	0.98				■				■
	U47GB	1010611	38/30	1.5/1.18	17,5	0.69	■				■			
	U47	1010742	38/30	1.5/1.18	19	0.75		■				■		
	U47HD	2222091	38/30	1.5/1.18	22	0.87			■				■	
	U47 52	1010429	38/30	1.5/1.18	25	0.98				■				■

Surface Mining • Surface Miners Tools

Gold

TSCX Series/KSMX Series

Dimensions below are shown in millimeters and (inches).

TSCX Series



TS19C X

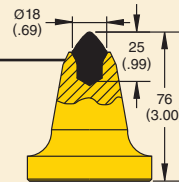

order number	catalog number	grade
4066765	TS19C X	K3560MH

TS32C X

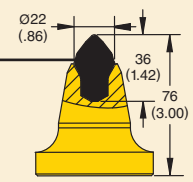

order number	catalog number	grade
4066821	TS32C X	K3560MH

TS31C X

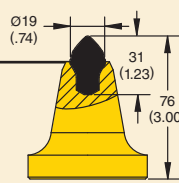

order number	catalog number	grade
4066872	TS31C X	K3560MH

TS30C

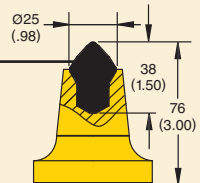

order number	catalog number	grade
4050638	TS30C	K3560MH

Retainer

TR3 Retainer



order number	catalog number
4073124	TR3 RETAINER



Silver

TS Series/KSM Series

Dimensions below are shown in millimeters and (inches).

TS Series



■ TS19

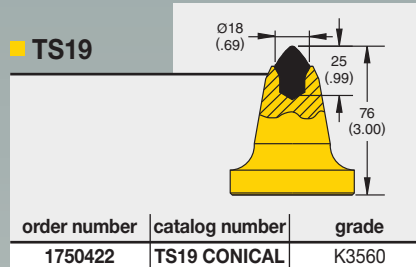

■ TS31

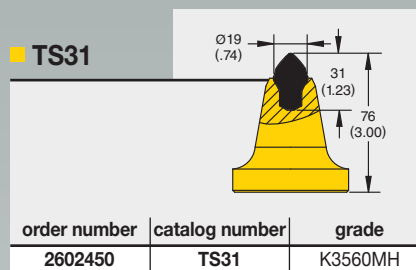

■ TS32

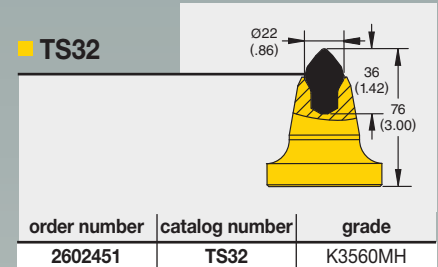

■ TS30

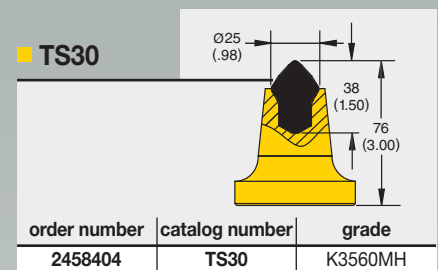

KSM Series • Made to Order



■ KSM42 S3

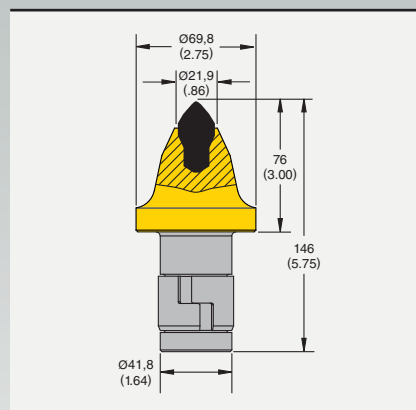

■ KSM42 E4

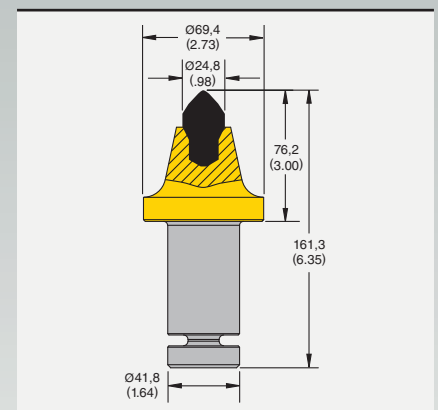

Retainers

■ KR112 Retainer (TS Series)

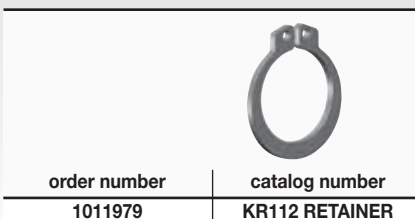

■ CM6H Retainer (KSM Series)

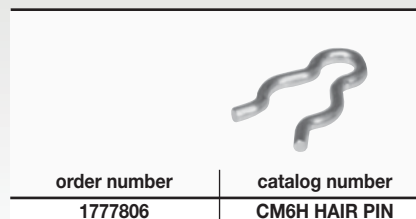

Bronze

U Series

Dimensions below are shown in millimeters and (inches).

U Series

U47GB

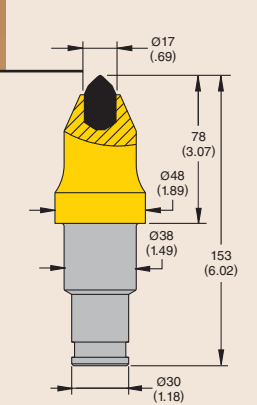

order number	catalog number	grade
1010611	U47GB	K3570

U47

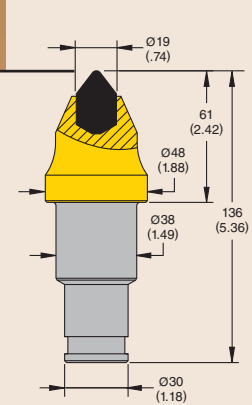

order number	catalog number	grade
1010742	C7/U47	K3560

U47HD

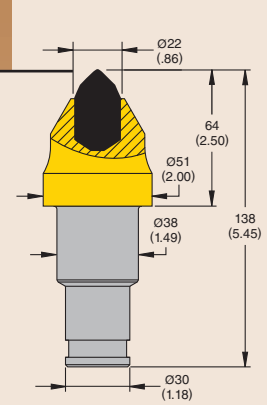

order number	catalog number	grade
2222091	U47HD	K3560

U47 52

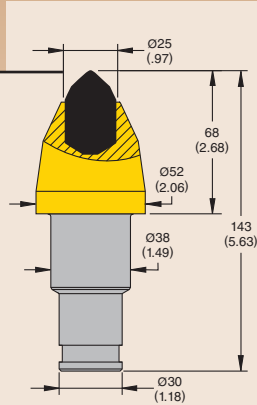

order number	catalog number	grade
1010429	U47 52	K3560

Retainer

KR112 Retainer



order number	catalog number
1011979	KR112 RETAINER

Other Surface Miner Products

Drums



Blocks



Surface Mining • Surface Miner Tools



Crusher Tooling and Sizing

For the sizing and crushing of soft- to medium-type materials.



Features and Benefits

- Provides straight, tapered, and stepped shank tools.
- Large selection of carbide tip sizes and shapes.
- External retainer systems.
- Fully heat-treated steel body.
- Superior impact strength for long-lasting tool life.
- Hard facing is available.
- Easy to install.

Reliability

- Easy installation and removal.
- Safe removal of tools.
- Extended tool life.
- Improved and protected braze joint slows steel wash for extended tool life.
- Tools fit standard block sizes.

Complete Portfolio

- Five different shank sizes.
- Twelve different gage lengths.
- Our tools fit most feeder breakers and sizers.

Crusher Tooling • 52mm (2.06") Shank

Dimensions below are shown in millimeters and (inches).

Surface Mining • Crusher Tooling and Sizing

■ U200 HF 2.2 17.5

- Triple angle, plug tip.
- Heavy cutting conditions.

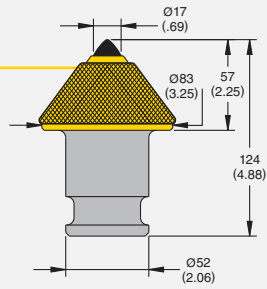

order number	catalog number	grade
2248807	U200HF 2.2 17.5	K3570

■ AM956DB

- 75° angle, plug tip.
- Medium cutting conditions.

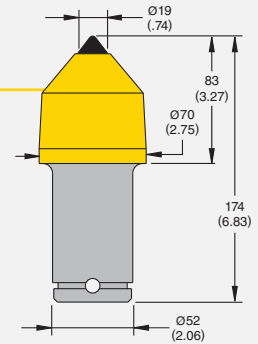

order number	catalog number	grade
1326980	AM956DB	610X02S

■ U200TS 5.0 .75HF

- 75° angle, plug tip.
- Medium cutting conditions.

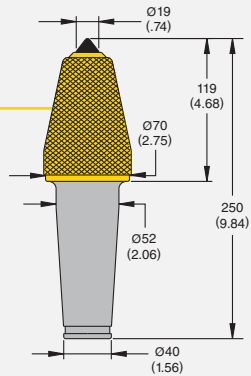

order number	catalog number	grade
1723538	U200TS 5.0 .75HF	K3560

■ U200HF 4.0.75

- 75° angle, plug tip.
- Medium cutting conditions.

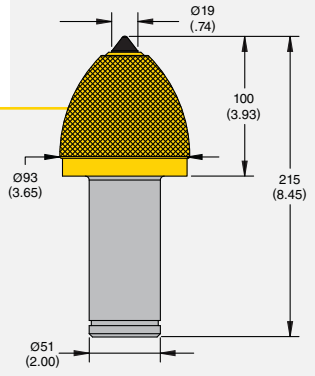

order number	catalog number	grade
2240028	U200HF 4.0 .75	K3560

■ U200 TSHF 3.2 .75

- 75° angle, plug tip.
- Medium cutting conditions.

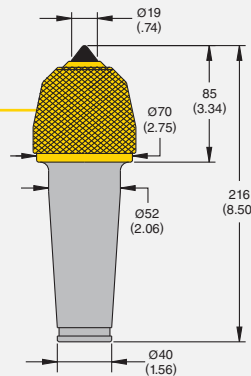

order number	catalog number	grade
2288279	U200 TSHF 3.2 .75	K3560

■ U200 5.0 .75HF

- 75° angle, plug tip.
- Heavy cutting conditions.

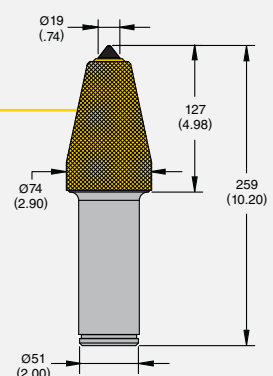

order number	catalog number	grade
1531305	U200 5.0 .75HF	K3560

Crusher Tooling • 52mm (2.06") Shank

Dimensions below are shown in millimeters and (inches).

■ U200TSHF 4.2 19.5

- 75° angle, plug tip.
- Heavy cutting conditions.

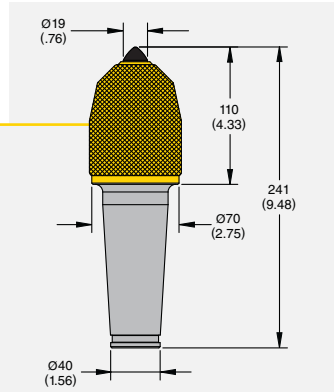

order number	catalog number	grade
3659861	U200TSHF 4.2 19.5	K3560

■ U200 5.3 .97 HF

- 23mm (1") plug tip.
- Heavy cutting conditions.

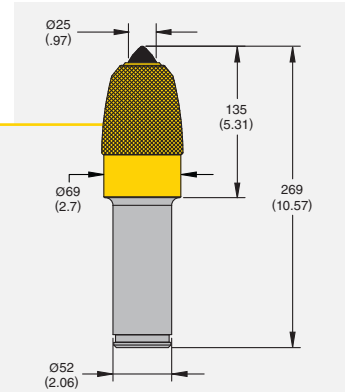

order number	catalog number	grade
3898246	U200 5.3 .97 HF	K3560

Surface Mining • Crusher Tooling and Sizing

Crusher Tooling • 76mm (3") Shank

Dimensions below are shown in millimeters and (inches).

Surface Mining • Crusher Tooling and Sizing

■ KXLC-M01 Extra-Large Conical Bit

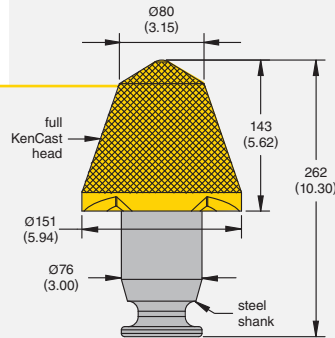

- EASY-PULL notches are engineered to increase productivity, plus enable quick and safe removal.
- Large base provides excellent block protection.
- Superior wear resistance over AR and welded overlay products.
- Tungsten carbide body offers superior wear life of 2.5 to 1.
- The metallurgically bonded tungsten carbide in the body of the tool enables superior impact strength.
- Extra-large bit weighs 15,875 kg (35 lbs).

order number

1996324

catalog number

KXLC-M01

Accessories

■ KR156 Retainer

- 40mm (1.56") snap ring for tapered shank crusher tools.



order number

1732772

catalog number

SHR156

■ KR200 Retainer

- Replacement 50mm (2") snap ring for U170K225S, U90K225S, U90K175S, and U80K175S sleeves.



order number

1011893

catalog number

KR200 RETAINER

■ U200TS Block Spacer

- Use in conjunction with tapered shank tools and a 52mm (2.06") bore block.

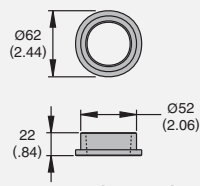

order number

1755052

catalog number

BLOCK SPACER

■ KRP200 Pliers

- For use on KR200 and KR225 snap rings
- Replaceable tips (item 1012073).



order number

1012063

catalog number

KRP200 PLIER

Crusher Tooling • 51mm (2") Shank

Dimensions below are shown in millimeters and (inches).

■ U200 3.2 .75

- 75° angle, plug tip.
- Heavy cutting conditions.

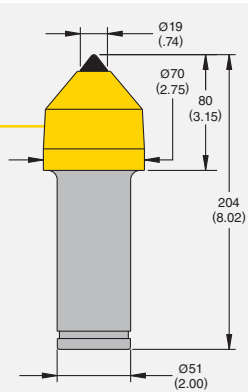

order number	catalog number	grade
2223173	U200 3.2 .75	K3560

■ U200HF 4.0 .75

- 75° angle, plug tip.
- Heavy cutting conditions.

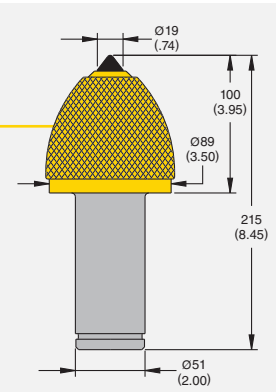

order number	catalog number	grade
2240028	U200HF 4.0 .75	

■ AM941HF

- 75° angle, plug tip.
- Medium cutting conditions.

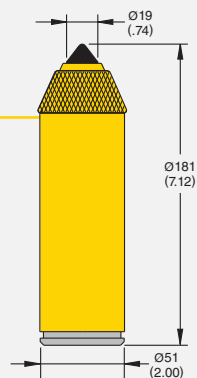

order number	catalog number	grade
1851744	AM941 HF	K3560

Crusher Tooling • 51mm (2") Shank

Dimensions below are shown in millimeters and (inches).

Surface Mining • Crusher Tooling and Sizing

■ AM942DB

- 75° angle, plug tip.
- Medium cutting conditions.

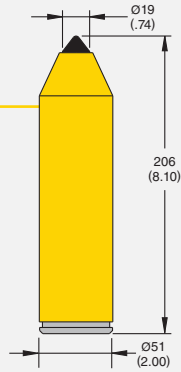

order number	catalog number	grade
1326986	AM942DB	610X02S

■ AM942DBHF

- 75° angle, plug tip.
- Medium cutting conditions.

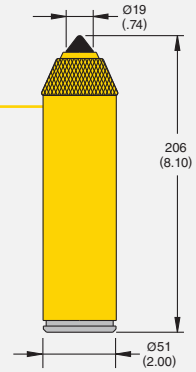

order number	catalog number	grade
1808476	AM942DB HF	610X028

■ AM943DB

- 75° angle, plug tip.
- Medium cutting conditions.

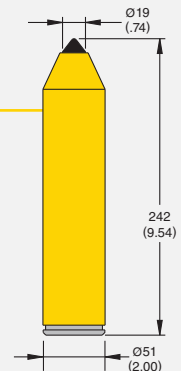

order number	catalog number	grade
1326985	AM943DB	610X02S

Accessories

■ KR200 Retainer

- Replacement 50mm (2") snap ring for U170K225S, U90K225S, U90K175S, and U80K175S sleeves.



order number	catalog number
1011893	KR200 RETAINER

Crusher Tooling • 38mm (1.50") Shank

Dimensions below are shown in millimeters and (inches).

■ KBB2

- 75° angle, plug tip.
- Heavy cutting conditions.

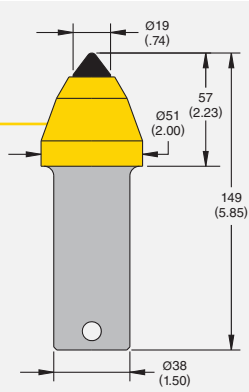

order number	catalog number	grade
1010312	KBB2	K3560

■ KBB2 1

- 75° angle, plug tip.
- Heavy cutting conditions.

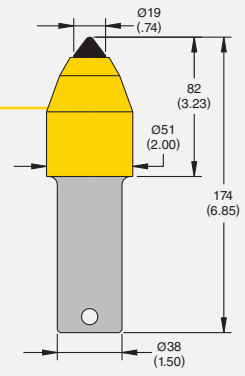

order number	catalog number	grade
1176205	KBB2 1 Breaker Bit Assembly	K3560

■ KBB2 1 3/4

- 75° angle, plug tip.
- Medium cutting conditions.

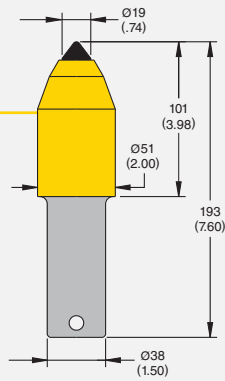

order number	catalog number	grade
1238793	KBB2 1 3/4	K3560

Surface Mining • Crusher Tooling and Sizing

Crusher Tooling • 30mm (1.18") Shank

Dimensions below are shown in millimeters and (inches).

Surface Mining • Crusher Tooling and Sizing

■ C4 1/U44 1

- 75° angle, plug tip.
- Medium cutting conditions.

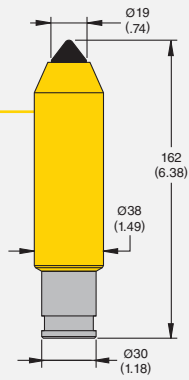

order number	catalog number	grade
1010776	C4 1/U44 1	K3560

■ C4/U44

- 75° angle, plug tip.
- Medium cutting conditions.

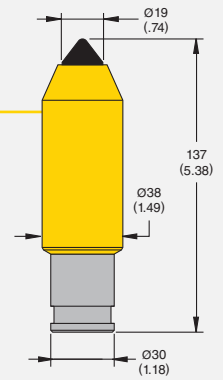

order number	catalog number	grade
1010761	C4/U44	K3560

Crusher Tooling • 38mm/30mm (1.50"/1.18") Step Shank

Dimensions below are shown in millimeters and (inches).

■ KSM1

- 75° angle, narrow-bottom tip.
- Light cutting conditions.

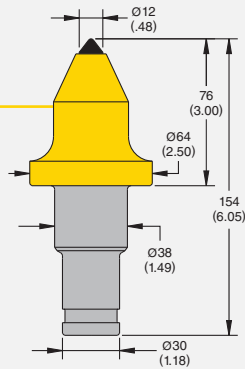

order number	catalog number	grade
1730570	KSM1	K3560

■ C7/U47

- 75° angle, plug tip.
- Heavy cutting conditions.

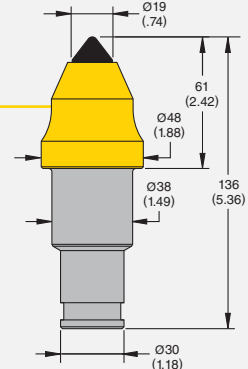

order number	catalog number	grade
1010742	C7/U47	K3560

■ U47 52

- Triple angle, plug tip.
- Severe cutting conditions.

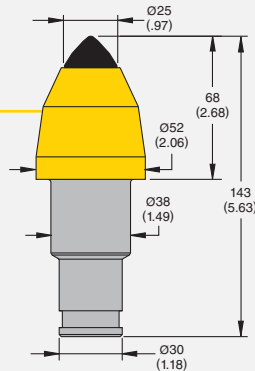

order number	catalog number	grade
1010429	U47 52	K3560

■ U47HD

- Triple angle, plug tip.
- Heavy cutting conditions.

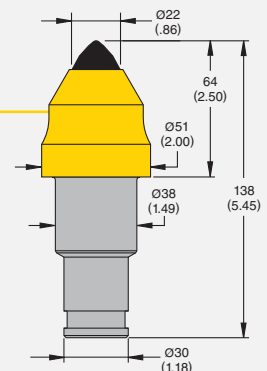

order number	catalog number	grade
2222091	U47HD	K3560

■ TS11

- Triple angle, plug tip.
- Heavy cutting conditions.

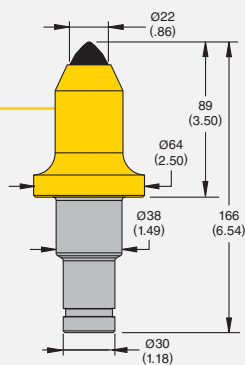

order number	catalog number	grade
1532879	TS11	K3560

■ U47GB

- Triple angle, plug tip.
- Medium cutting conditions.

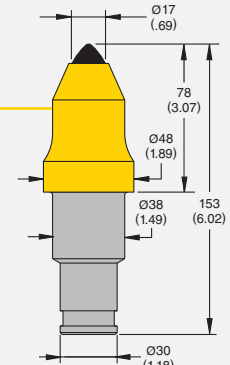

order number	catalog number	grade
1010611	U47GB	K3570

Crusher Tooling • 38mm/30mm (1.50"/1.18") Step Shank

Dimensions below are shown in millimeters and (inches).

Surface Mining • Crusher Tooling and Sizing

■ KSM7

- Triple angle, plug tip.
- Light cutting conditions.

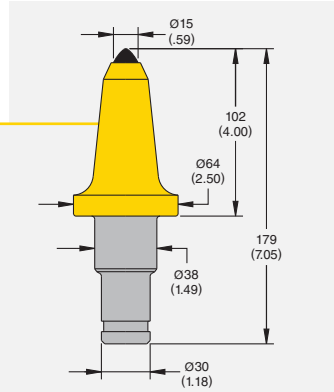

order number	catalog number	grade
2401373	KSM7	K3560

■ U47 1

- 75° angle, plug tip.
- Medium cutting conditions.

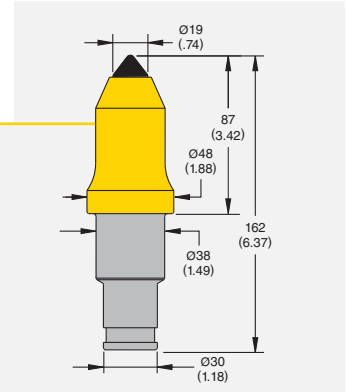

order number	catalog number	grade
1010327	U47 1	K3560



Wear Solutions

Kennametal is the global benchmark for effectively and efficiently combating extremes of wear, impact, and abrasion.



Regardless of how demanding or unique your requirement, we provide an unbeatable portfolio of affordable, best-in-class solutions:

- Plate.
- Welding electrodes.
- Bar.
- Pins.
- Custom processing.

Our overall ultra-durable, high-performance offering includes:

- Drums and related tooling systems.
- Bucket lips.

Super-C

Chromium Carbide Abrasion-Resistant Plate

Super-C is a chromium carbide overlay, wear-resistant plate with a mild steel base for weldability. Tricon's unique cladding process produces a harder, tougher, and more wear-resistant surface, making Super-C superior to any other chromium carbide plate available on the market.

Features and Benefits:

- Mild steel base plate can be easily welded, bolted, or studded to existing structures.
- Can be applied to nickel-based, stainless, and other steel substrates.
- Ideal for severe abrasion and moderate impact applications.
- Maximum carbide concentration and alignment throughout the proprietary process makes Super-C the most wear-resistant overlay plate on the market.
- Consistent hardness and controlled chemistry.
- Excellent impact, abrasion, corrosion, and heat resistance.
- Proprietary herringbone pattern breaks up flow channels and premature plate wear, regardless of installation direction.



Tri-Braze

Impact- and Abrasion-Resistant Alloy Steel

Designed to tackle your toughest impact and abrasion applications, Tri-Braze combines a balance of alloying elements with controlled heat treating and extremely low sulfur for an ideal hardness/toughness ratio.

Tri-Braze is the standard by which all other impact- and abrasion-resistant alloy steels are measured.

Features and Benefits:

- High hardness for better wear resistance (444 BHN).
- Balanced alloy steel chemistry for optimum hardness/toughness ratio.
- Extremely low sulfur content, fine-grain structure, and excellent internal cleanliness provides the highest impact resistance in the industry.
- Tri-Braze chemistry and processing ensures full hardness throughout the plate and avoids the soft middle of lesser quality plates.
- Long performance life and less downtime lowers overall maintenance costs.
- Tri-Braze chemistry provides excellent weldability in field conditions.
- Available in thicknesses up to 254mm (10"), widths up to 3048mm (120"), and lengths up to 4775,2mm (288").

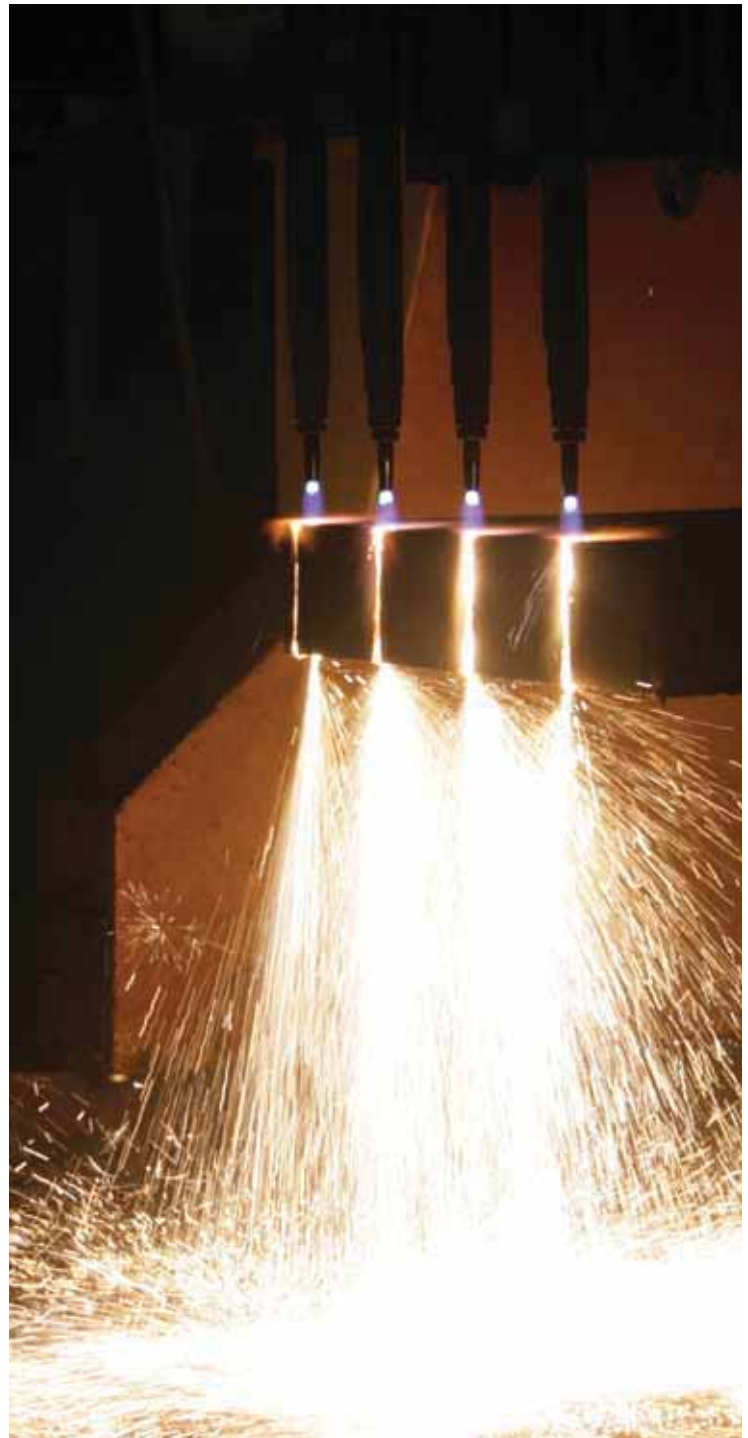

Surface Mining • Wear Solutions

Special Treated Pins

Delivering the Ultimate in Quality and Performance

Through careful selection, control, and proprietary processing of raw materials, Tricon Special Treated Pins are the ultimate in quality and performance. The final result is a product that delivers substantial savings, less equipment downtime, and increased productivity.



Induction Hardened Pins

Through the use of our proprietary material and the latest in heat-treat technology, Tricon Induction Hardened Pins achieve an unmatched depth of hardness while still maintaining an extremely tough inner core.

Super-X™ Pins

Developed specifically for applications involving severe heat and wear, this unique pin is a composite product consisting of a tough inner core and a super-hard, heat-resisting surface.

Pin Stock

Downtime of wear-prone equipment is not always scheduled. To maximize your productivity, we maintain pin stock inventories to fill your order on short notice. Tricon Pin Stock is mill certified, ultrasonically inspected, heat treated, straightened, and stress relieved to our specifications.

Manufacturing

Because Tricon believes in producing the highest quality pin on the market, our machine shop has been equipped with the latest in CNC equipment. Manufacturing is closely monitored throughout the machining operation to ensure close tolerances and consistency.

Prime Arc

Welding Consumables

Prime Arc welding consumables are designed to provide our customers with the highest quality hard surfacing, build-up, and joining products available in the industry. More than 35 years of welding and fabrication experience has enabled us to develop a unique product line that provides extended service life while reducing costly downtime.

Joining

Prime Arc joining electrodes and wires are formulated for field welding under the most difficult field conditions. We have a full line of electrodes and wires designed to join high-strength, abrasion-resistant steel, manganese steel, and dissimilar metals.

Build-Up

Rebuilt parts often exceed OEM specifications for service life. Prime Arc build-up consumables are used for repairing and resurfacing of expensive, worn parts.

Hard Surfacing

Whatever your wear problem, there is a Prime Arc wire designed for your needs. We have a full line of chromium carbide, complex carbide, tungsten carbide, manganese, martensitic, and tool steel consumables that can handle hard rock, earth moving, metal-to-metal, and other demanding applications.

Tubular

Our unique tubular hard surfacing rods provide extremely high deposition rates and are available in a variety of chromium and tungsten carbide formulations.



Surface Mining • Wear Solutions



SAFETY NOTE

Kennametal has no control over the end use of its products or the environment into which those products are placed. Kennametal urges its customers to adhere to the recommended standards of use of their machines and tools and that they follow procedures that ensure safe operations.

The information included in this catalog and other recommendations on machining practices referred to herein are only advisory in nature and do not constitute representations or warranties and are not necessarily appropriate for any particular work environment or application.

Kennametal Inc. encourages the safe use of its products.

To help avoid personal injury or damage to tools, please follow these recommended guidelines:

- Wear approved personal protection equipment, including eye, ear, head, and foot protection.
- Make sure tools are properly seated and securely retained.
- Do not strike tools with metal objects. Carbide tips could shatter.
- Exercise care when removing tools.
- Inspect tools before each use. If they are dull, cracked, burred, or bent, do not use them.
- Operate all machines within the OEM parameters and with safety in mind. Stand clear of machines in use and make sure protective guards are in place.
- Do not change tools when the drum is moving or still engaged.

www.kennametal.com



**Argentina**

Phone: 54.011.4719.0700

Fax: 54.011.4719 6116

Australia/New Zealand

Phone: 61.7.3801.5844

Fax: 61.7.3801.5826

sydney.service@kennametal.com

Brazil/Latin America

Phone: 55.19.3936.9200

Fax: 55.19.3936.9201

Chile

Phone: 56.2.2641177

Fax: 001.888.442.4964

China

Phone: 86.400.6501.388

Fax: 86.10.8561.5263

Germany/European Served Area

Phone: 49.6172.737.498

Fax: 49.6172.737.42.453

mcs-ag.service@kennametal.com

India

Phone: 91.80.2839.4321

Phone: 91.80.2219.8444

Fax: 91.80.2839.1300

bangalore.information@kennametal.com

Japan

Phone: 81.3.3820.2855

Fax: 81.3.3820.2800

Korea

Phone: 82.2.2109.6967

Fax: 82.2.2109.6981

Malaysia/Indonesia

Phone: 6.03.5569.9080

Fax: 6.03.5569.0080

Poland/Slovakia/Baltics

Phone: 48.32.42.15.888

Phone: 48.32.42.15.405

Fax: 48.32.47.89.112

South Africa/Sub Saharan Area

Phone: 27.11397.3540

Fax: 27.11397.3222

**Thailand/Singapore/
Vietnam/Philippines**

Phone: 66.2642.3455

Phone: 66.2246.8025.32

Fax: 66.2641.2736.8

United States/Canada/Mexico

Phone: 800.458.3608

Fax: 800.521.3319

mcs-na.service@kennametal.com

World and Corporate Headquarters

Kennametal Inc.
1600 Technology Way
Latrobe, PA 15650 USA
Phone: 800.446.7738 (United States and Canada)
ftmill.service@kennametal.com

European Headquarters

Kennametal Europe GmbH
Rheingoldstrasse 50
CH 8212 Neuhausen am Rheinfl
Switzerland
Phone: 41.52.6750.100
neuhausen.info@kennametal.com

Asia-Pacific Headquarters

Kennametal Pte. Ltd.
ICON@IBP # 01-02/03/05
3A International Business Park
Singapore 609935
Phone: 65.6.2659222
sales@kennametal.com.sg

India Headquarters

Kennametal India Limited
8/9th Mile, Tumkur Road
Bangalore - 560.073
Phone: 91.80.2839.4321
bangalore.information@kennametal.com



Kennametal Inc.
1600 Technology Way
Latrobe, PA 15650
USA

www.kennametal.com