



DREHVERBINDUNGEN

Laufkreisdurchmesser 414 - 1094 mm
Maß- und Umschlüsseltabellen

SLEWING BEARINGS

Raceway diameters 414 - 1094 mm
Dimension and interchange tables



L1 Serie Kugeldrehverbindungen; 1-reihig (Flanschlager)

Für Standardanwendungen mit moderaten Belastungen und geringen Anforderungen an die Anschlusskonstruktion

Anwendungen: allgemeiner Maschinenbau, leichte Schwenktische, Materialhandling, Schienenfahrzeuge

L1 Series Single-row ball slewing bearings (Flange bearings)

For standard applications with moderate loads and low mounting structure requirements

Applications: general mechanical engineering, light turntables, materials handling, railed vehicles



X1 Serie Kreuzrollen-Drehverbindungen

Für Anwendungen mit vorrangig gleichmäßigem Drehwiderstand bei wechselnden Belastungen sowie bei hoher Genauigkeit und Steifigkeit.

Anwendungen: Werkzeugmaschinenbau, Tunnelvortriebsmaschinen, Positioniereinrichtungen

X1 Series Crossed-roller slewing bearings

Primarily for service conditions requiring a uniform rotational resistance despite changing loads, tension and high requirements of precision and stiffness.

Applications: machine tool engineering, tunnelling machinery and positioning systems

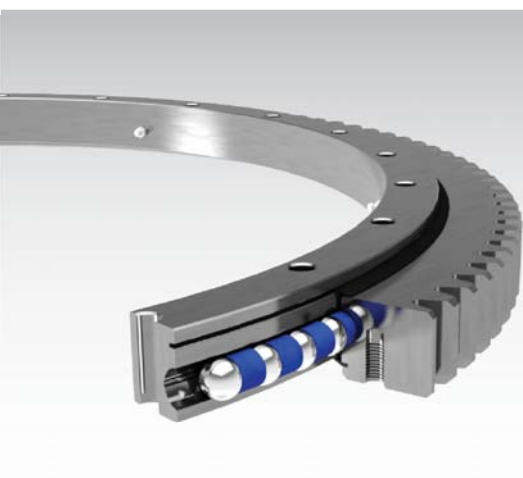

K1 Serie Kugeldrehverbindungen; 1-reihig (Vierpunktlager)

Die Drehverbindungen sind vorrangig für robuste und hohe statische Belastungen geeignet.

Anwendungen: Krane, Baumaschinen, Maschinen- und Anlagenbau, Windkraftanlagen

K1 Series Single-row ball slewing bearings (Four point contact bearings)

Primarily used for tough service conditions requiring a high static load capacity.

Applications: cranes, building machinery, plant and mechanical engineering, wind turbines

Weitere Informationen

Weitere Drehverbindungen aus unserem Standardsortiment, kundenspezifische Sonderlösungen und technische Informationen zur

- Auslegung
- Werkstoffauswahl
- Verzahnung
- Verschraubung
- Befettung
- Oberflächenbeschichtung und
- Qualitätsüberwachung

finden Sie in unserem Hauptkatalog (Katalog 88).

Bitte beachten Sie die dort enthaltenen technischen Hinweise zu Verpackung, Transport und Lagerung sowie Montage und Wartung. Diese haben auch Gültigkeit für die hier aufgeführten Drehverbindungen.

Further information

You can find further standard slewing bearings, customized solutions and technical information about

- design
- material selection
- gearing
- mounting bolts
- greasing
- surface coating and
- quality control

in our main catalog (catalog 88).

Please pay attention to the instructions for packing, transport and storage as well as mounting and maintenance in the main catalog. Those instructions are valid for the slewing bearings listed herein.



Kugeldrehverbindungen; 1-reihig, Flanschlager

Single-row ball slewing bearings, flange bearings

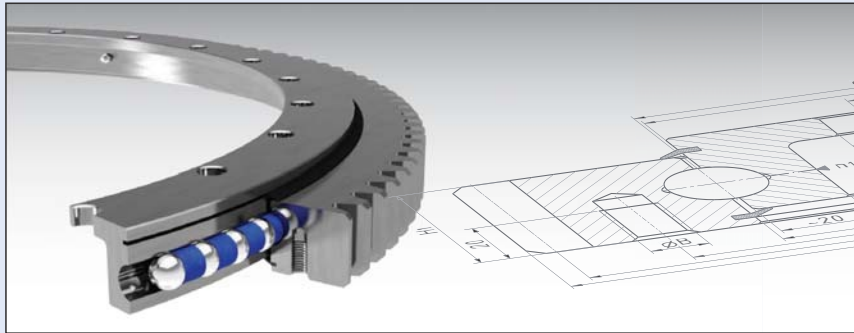

L 11 · 20 · 1094 – Zeichnungsendnummer
 – Drawing end number

Bauform	Laufbahn	Verzahnung	Wälzkörper Ø	Laufkreis Ø
K = Kugel-Drehverbindung L = Leichtbauform, Flanschlager X = Kreuzrollen-Drehverbindung R = Rollen-Drehverbindung	1 = einreihig 2 = zweireihig 3 = dreireihig	0 = ohne 1 = außen gerade 2 = innen gerade 3 = außen schräg 4 = innen schräg	Kugeldurchmesser oder Rollendurchmesser in mm	Durchmesser des Laufkreis in mm
Model	Raceway	Gear	Rolling element Ø	Raceway Ø
K = ball slewing bearing L = light-weight flange bearing X = crossed-roller slewing bearing R = roller slewing bearing	1 = single-row 2 = double-row 3 = triple-row	0 = without gear 1 = outer straight gear 2 = inner straight gear 3 = outer helical gear 4 = inner helical gear	Ball diameter or roller diameter in mm	Diameter of the raceway in mm

Umschlüsseltabelle

Interchange table

Typbezeichnung Type designation	austauschbar mit interchangeable with	
unverzahnt - without gear		
L10.20.0414.810	VLU200414	230.20.0400.013 Typ 21/520.0
L10.20.0544.810	VLU200544	230.20.0500.013 Typ 21/650.0
L10.20.0644.810	VLU200644	230.20.0600.013 Typ 21/750.0
L10.20.0744.810	VLU200744	230.20.0700.013 Typ 21/850.0
L10.20.0844.810	VLU200844	230.20.0800.013 Typ 21/950.0
L10.20.0944.810	VLU200944	230.20.0900.013 Typ 21/1050.0
L10.20.1094.810	VLU201094	230.20.1000.013 Typ 21/1200.0
außenverzahnt - external gear		
L11.20.0414.810	VLA200414-N	231.20.0400.013 Typ 21/520.1
L11.20.0544.810	VLA200544-N	231.20.0500.013 Typ 21/650.1
L11.20.0644.810	VLA200644-N	231.20.0600.013 Typ 21/750.1
L11.20.0744.810	VLA200744-N	231.20.0700.013 Typ 21/850.1
L11.20.0844.810	VLA200844-N	231.20.0800.013 Typ 21/950.1
L11.20.0944.810	VLA200944-N	231.20.0900.013 Typ 21/1050.1
L11.20.1094.810	VLA201094-N	231.20.1000.013 Typ 21/1200.1
innenverzahnt - internal gear		
L12.20.0414.810	VLI200414-N	232.20.0400.013 Typ 21/520.2
L12.20.0544.810	VLI200544-N	232.20.0500.013 Typ 21/650.2
L12.20.0644.810	VLI200644-N	232.20.0600.013 Typ 21/750.2
L12.20.0744.810	VLI200744-N	232.20.0700.013 Typ 21/850.2
L12.20.0844.810	VLI200844-N	232.20.0800.013 Typ 21/950.2
L12.20.0944.810	VLI200944-N	232.20.0900.013 Typ 21/1050.2
L12.20.1094.810	VLI201094-N	232.20.1000.013 Typ 21/1200.2

Kugeldrehverbindungen; 1-reihig, Flanschlager

Single-row ball slewing bearings, flange bearings

Abmessungen und Gewicht Dimensions and weight							Befestigungsbohrungen Fastening boreholes				Zentrierungen Centerings			
Außendurchmesser Outer diameter	Innendurchmesser Inner diameter	Gesamthöhe Total height	Höhe Außenring Outer ring height	Höhe Innenring Inner ring height	Durchmesser oben Upper diameter	Durchmesser unten Lower diameter	Lochkreisdurchmesser Diam. of borehole circle	Bohrungsanzahl Number of boreholes	Bohrungsdurchmesser Borehole diameter	Lochkreisdurchmesser Diam. of borehole circle	Bohrungsanzahl Number of boreholes	Bohrungsdurchmesser Borehole diameter	Zentrierung am Außenring Centering at outer ring	Zentrierung am Innenring Centering at inner ring
H	H ₁	H ₂	O	U	G	La								

Verzahnung und Zahnkräfte Gear and gear tooth forces						
Teilkreisdurchmesser Pitch circle diameter	Modul Module	Zähnezahl Number of teeth	Profilverschiebungsfaktor Profile shift coefficient	Zulässige Zahnkraft Permitted gear tooth force	Maximal zulässige Zahnkraft Max. permitted gear tooth force	Anzahl der Schmiernippel Number of grease nipples

unverzahnt - without gear

Typbezeichnung Type designation	Da	Di	H	H ₁	H ₂	O	U	G	La	na	B	Li	ni	b	Da*	Di*
[mm]	[mm]	[mm]	[mm]	[mm]	[mm]	[mm]	[mm]	[kg]	[mm]	[-]	[mm]	[mm]	[-]	[mm]	[mm]	[mm]
L10.20.0414.810	518	304	56	47,5	47,5	412,5	415,5	24	490	8	18	332	12	18	516	306
L10.20.0544.810	648	434	56	47,5	47,5	542,5	545,5	31	620	10	18	462	14	18	646	436
L10.20.0644.810	748	534	56	47,5	47,5	642,5	645,5	37	720	12	18	562	16	18	746	536
L10.20.0744.810	848	634	56	47,5	47,5	742,5	745,5	43	820	12	18	662	16	18	846	636
L10.20.0844.810	948	734	56	47,5	47,5	842,5	845,5	48	920	14	18	762	18	18	946	736
L10.20.0944.810	1048	834	56	47,5	47,5	942,5	945,5	54	1020	16	18	862	20	18	1046	836
L10.20.1094.810	1198	984	56	47,5	47,5	1092,5	1095,5	63	1170	16	18	1012	20	18	1196	986

d _o	m	z	x	fz norm	fz max	n1	Pos.
[mm]	[mm]	[-]	[-]	[kN]	[kN]	[-]	
-	-	-	-	-	-	4	1
-	-	-	-	-	-	4	2
-	-	-	-	-	-	4	3
-	-	-	-	-	-	4	4
-	-	-	-	-	-	4	5
-	-	-	-	-	-	4	6
-	-	-	-	-	-	4	7

außenverzahnt - external gear

Typbezeichnung Type designation	Da	Di	H	H ₁	H ₂	O	U	G	La	na	B	Li	ni	b	U*	Di*
[mm]	[mm]	[mm]	[mm]	[mm]	[mm]	[mm]	[mm]	[kg]	[mm]	[-]	[mm]	[mm]	[-]	[mm]	[mm]	[mm]
L11.20.0414.810	503,3	304	56	44,5	47,5	412,5	415,5	30	455	10	M12	332	12	18	417	306
L11.20.0544.810	640,3	434	56	44,5	47,5	542,5	545,5	42	585	14	M12	462	14	18	547	436
L11.20.0644.810	742,3	534	56	44,5	47,5	642,5	645,5	49	685	16	M12	562	16	18	647	536
L11.20.0744.810	838,1	634	56	44,5	47,5	742,5	745,5	55	785	18	M12	662	16	18	747	636
L11.20.0844.810	950,1	734	56	44,5	47,5	842,5	845,5	66	885	18	M12	762	18	18	847	736
L11.20.0944.810	1046,1	834	56	44,5	47,5	942,5	945,5	72	985	20	M12	862	20	18	947	836
L11.20.1094.810	1198,1	984	56	44,5	47,5	1092,5	1095,5	84	1135	22	M12	1012	20	18	1097	986

d _o	m	z	x	fz norm	fz max	n1	Pos.
[mm]	[mm]	[-]	[-]	[kN]	[kN]	[-]	
495	5	99	0	16	24	4	1
630	6	105	0	21	32	4	2
732	6	122	0	21	32	4	3
828	6	138	0	21	32	4	4
936	8	117	0	28	42	4	5
1032	8	129	0	28	42	4	6
1184	8	148	0	28	42	4	7

innenverzahnt - internal gear

Typbezeichnung Type designation	Da	Di	H	H ₁	H ₂	O	U	G	La	na	B	Li	ni	b	Da*	U*
[mm]	[mm]	[mm]	[mm]	[mm]	[mm]	[mm]	[mm]	[kg]	[mm]	[-]	[mm]	[mm]	[-]	[mm]	[mm]	[mm]
L12.20.0414.810	518	325	56	47,5	44,5	415,5	412,5	28	490	8	18	375	12	M12	516	411
L12.20.0544.810	648	444	56	47,5	44,5	545,5	542,5	38	620	10	18	505	16	M12	646	541
L12.20.0644.810	748	546	56	47,5	44,5	645,5	642,5	45	720	12	18	605	18	M12	746	641
L12.20.0744.810	848	648	56	47,5	44,5	745,5	742,5	52	820	12	18	705	20	M12	846	741
L12.20.0844.810	948	736	56	47,5	44,5	845,5	842,5	62	920	14	18	805	20	M12	946	841
L12.20.0944.810	1048	840	56	47,5	44,5	945,5	942,5	68	1020	16	18	905	22	M12	1046	941
L12.20.1094.810	1198	984	56	47,5	44,5	1095,5	1092,5	82	1170	16	18	1055	24	M12	1196	1091

d _o	m	z	x	fz norm	fz max	n1	Pos.
[mm]	[mm]	[-]	[-]	[kN]	[kN]	[-]	
335	5	67	0	18	26	4	1
456	6	76	0	24	35	4	2
558	6	93	0	24	35	4	3
660	6	110	0	24	35	4	4
752	8	94	0	31	47	4	5
856	8	107	0	31	47	4	6
1000	8	125	0	31	47	4	7

* Lager optional mit Zentrierung lieferbar; Außendurchmesser mit -IT8 und Innendurchmesser mit +IT8 toleriert;
 * Bearings available with optional centering; outer diameter tolerance -IT8; inner diameter tolerance +IT8;

Zentrierhöhe für Da* und Di* 12 mm, für U* min. 4,4 mm
 centering height for Da* and Di* 12 mm, for U* min. 4,4 mm

Pos.	Tragzahlen / Load ratings			
	statisch / static		dynamisch / dynamic	
	axial C _{0a} [kN]	radial C _{0r} [kN]	axial C _a [kN]	radial C _r [kN]
1	295	110	169	111
2	385	145	188	123
3	455	171	200	131
4	530	198	211	138
5	600	224	222	145
6	670	250	231	151
7	770	290	244	160

Axialspiel / Axial clearance: 0...0,7 mm**
 Radialspiel / Radial clearance: 0...0,5 mm**

** Lager auch mit eingegengtem Spiel oder Vorspannung lieferbar
 ** Bearings available with restricted internal clearance or preload

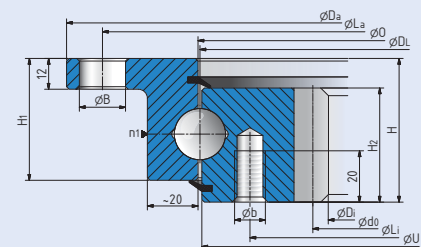
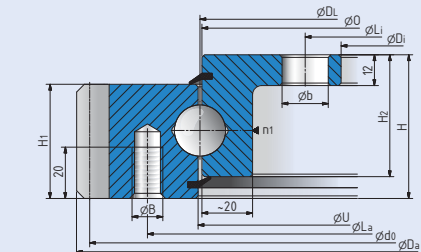
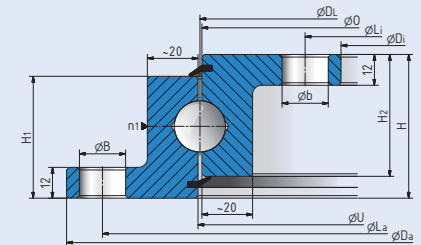

Kugeldrehverbindungen; 1-reihig, Vierpunktlager Single-row ball slewing bearings, four point contact bearings

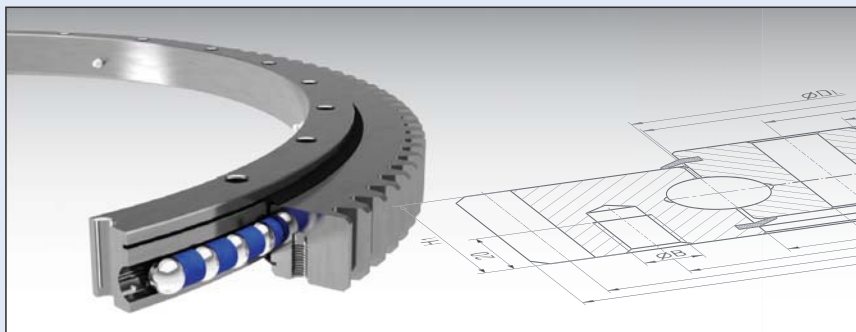

K 1 1 · 2 0 · 0 7 4 4 – Zeichnungsendnummer
– Drawing end number

Bauform	Laufbahn	Verzahnung	Wälzkörper Ø	Laufkreis Ø
K = Kugel-Drehverbindung L = Leichtbauform, Flanschlager X = Kreuzrollen-Drehverbindung R = Rollen-Drehverbindung	1 = einreihig 2 = zweireihig 3 = dreireihig	0 = ohne 1 = außen gerade 2 = innen gerade 3 = außen schräg 4 = innen schräg	Kugeldurchmesser oder Rollendurchmesser in mm	Durchmesser des Laufkreis in mm
Model	Raceway	Gear	Rolling element Ø	Raceway Ø
K = ball slewing bearing L = light-weight flange bearing X = crossed-roller slewing bearing R = roller slewing bearing	1 = single-row 2 = double-row 3 = triple-row	0 = without gear 1 = outer straight gear 2 = inner straight gear 3 = outer helical gear 4 = inner helical gear	Ball diameter or roller diameter in mm	Diameter of the raceway in mm

Umschlüsseltabelle Interchange table

Typbezeichnung Type designation	austauschbar mit interchangeable with	
unverzahnt - without gear		
K10.20.0414.810	VSU200414	060.20.0414.500.01.1503
K10.20.0544.810	VSU200544	060.20.0544.500.01.1503
K10.20.0644.810	VSU200644	060.20.0644.500.01.1503
K10.20.0744.810	VSU200744	060.20.0744.500.01.1503
K10.20.0844.810	VSU200844	060.20.0844.500.01.1503
K10.20.0944.810	VSU200944	060.20.0944.500.01.1503
K10.20.1094.810	VSU201094	060.20.1094.500.01.1503
außenverzahnt - external gear		
K11.20.0414.810	VSA200414-N	061.20.0414.500.01.1503
K11.20.0544.810	VSA200544-N	061.20.0544.500.01.1503
K11.20.0644.810	VSA200644-N	061.20.0644.500.01.1503
K11.20.0744.810	VSA200744-N	061.20.0744.500.01.1503
K11.20.0844.810	VSA200844-N	061.20.0844.500.01.1503
K11.20.0944.810	VSA200944-N	061.20.0944.500.01.1503
K11.20.1094.810	VSA201094-N	061.20.1094.500.01.1503
innenverzahnt - internal gear		
K12.20.0414.810	VSI200414-N	062.20.0414.500.01.1503
K12.20.0544.810	VSI200544-N	062.20.0544.500.01.1503
K12.20.0644.810	VSI200644-N	062.20.0644.500.01.1503
K12.20.0744.810	VSI200744-N	062.20.0744.500.01.1503
K12.20.0844.810	VSI200844-N	062.20.0844.500.01.1503
K12.20.0944.810	VSI200944-N	062.20.0944.500.01.1503
K12.20.1094.810	VSI201094-N	062.20.1094.500.01.1503

Kugeldrehverbindungen; 1-reihig, Vierpunktlager

Single-row ball slewing bearings, four point contact bearings

Abmessungen und Gewicht Dimensions and weight								Befestigungsbohrungen Fastening boreholes				Zentrierungen Centerings	
Außendurchmesser Outer diameter	Innendurchmesser Inner diameter	Gesamthöhe Total height	Höhe Außerring Outer ring height	Höhe Innerring Inner ring height	Durchmesser oben Upper diameter	Durchmesser unten Lower diameter	Gewicht Weight	Außenring Outer ring		Innenring Inner ring		Zentrierung am Außenring Centering at outer ring	Zentrierung am Innerring Centering at inner ring
								Lochkreisdurchmesser Diam. of borehole circle	Bohrungsanzahl Number of boreholes	Bohrungsdurchmesser Borehole diameter	Lochkreisdurchmesser Diam. of borehole circle		

Verzahnung und Zahnkräfte Gear and gear tooth forces							Maximal zulässige Zahnkraft Max. permitted gear tooth force	Anzahl der Schmiernippel Number of grease nipples
Teilkreisdurchmesser Pitch circle diameter	Modul Module	Zähnezahl Number of teeth	Profilverschiebungsfaktor Profile shift coefficient	Zulässige Zahnkraft Permitted gear tooth force	Profilverschiebungsfaktor Profile shift coefficient	Zulässige Zahnkraft Permitted gear tooth force		

unverzahnt - without gear

Typbezeichnung Type designation	Da	Di	H	H1	H2	O	U	G	La	na	B	Li	ni	b	Da*	Di*
	[mm]	[mm]	[mm]	[mm]	[mm]	[mm]	[mm]	[kg]	[mm]	[-]	[mm]	[mm]	[-]	[mm]	[mm]	[mm]
K10.20.0414.810	486	342	56	44,5	44,5	412,5	415,5	29	460	24	14	368	24	14	484	344
K10.20.0544.810	616	472	56	44,5	44,5	542,5	545,5	37	590	32	14	498	32	14	614	474
K10.20.0644.810	716	572	56	44,5	44,5	642,5	645,5	44	690	36	14	598	36	14	714	574
K10.20.0744.810	816	672	56	44,5	44,5	742,5	745,5	52	790	40	14	698	40	14	814	674
K10.20.0844.810	916	772	56	44,5	44,5	842,5	845,5	60	890	40	14	798	40	14	914	774
K10.20.0944.810	1016	872	56	44,5	44,5	942,5	945,5	67	990	44	14	898	44	14	1014	874
K10.20.1094.810	1166	1022	56	44,5	44,5	1092,5	1095,5	77	1140	48	14	1048	48	14	1164	1024

d _o	m	z	x	fz norm	fz max	n1	Pos.
[mm]	[mm]	[-]	[-]	[kN]	[kN]	[-]	
-	-	-	-	-	-	4	1
-	-	-	-	-	-	4	2
-	-	-	-	-	-	4	3
-	-	-	-	-	-	4	4
-	-	-	-	-	-	4	5
-	-	-	-	-	-	4	6
-	-	-	-	-	-	4	7

außenverzahnt - external gear

Typbezeichnung Type designation	Da	Di	H	H1	H2	O	U	G	La	na	B	Li	ni	b	U*	Di*
	[mm]	[mm]	[mm]	[mm]	[mm]	[mm]	[mm]	[kg]	[mm]	[-]	[mm]	[mm]	[-]	[mm]	[mm]	[mm]
K11.20.0414.810	503,3	342	56	44,5	44,5	412,5	415,5	31	455	20	M12	368	24	14	417	344
K11.20.0544.810	640,3	472	56	44,5	44,5	542,5	545,5	43	585	28	M12	498	32	14	547	474
K11.20.0644.810	742,3	572	56	44,5	44,5	642,5	645,5	52	685	32	M12	598	36	14	647	574
K11.20.0744.810	838,1	672	56	44,5	44,5	742,5	745,5	59	785	36	M12	698	40	14	747	674
K11.20.0844.810	950,1	772	56	44,5	44,5	842,5	845,5	71	885	36	M12	798	40	14	847	774
K11.20.0944.810	1046,1	872	56	44,5	44,5	942,5	945,5	77	985	40	M12	898	44	14	947	874
K11.20.1094.810	1198,1	1022	56	44,5	44,5	1092,5	1095,5	91	1135	44	M12	1048	48	14	1097	1024

d _o	m	z	x	fz norm	fz max	n1	Pos.
[mm]	[mm]	[-]	[-]	[kN]	[kN]	[-]	
495	5	99	0	16	24	4	1
630	6	105	0	21	32	4	2
732	6	122	0	21	32	4	3
828	6	138	0	21	32	4	4
936	8	117	0	28	42	4	5
1032	8	129	0	28	42	4	6
1184	8	148	0	28	42	4	7

innenverzahnt - internal gear

Typbezeichnung Type designation	Da	Di	H	H1	H2	O	U	G	La	na	B	Li	ni	b	Da*	U*
	[mm]	[mm]	[mm]	[mm]	[mm]	[mm]	[mm]	[kg]	[mm]	[-]	[mm]	[mm]	[-]	[mm]	[mm]	[mm]
K12.20.0414.810	486	325	56	44,5	44,5	415,5	412,5	31	460	24	14	375	24	M12	484	411
K12.20.0544.810	616	444	56	44,5	44,5	545,5	542,5	42	590	32	14	505	32	M12	614	541
K12.20.0644.810	716	546	56	44,5	44,5	645,5	642,5	50	690	36	14	605	36	M12	714	641
K12.20.0744.810	816	648	56	44,5	44,5	745,5	742,5	58	790	40	14	705	40	M12	814	741
K12.20.0844.810	916	736	56	44,5	44,5	845,5	842,5	69	890	40	14	805	40	M12	914	841
K12.20.0944.810	1016	840	56	44,5	44,5	945,5	942,5	76	990	44	14	905	44	M12	1014	941
K12.20.1094.810	1166	984	56	44,5	44,5	1095,5	1092,5	91	1140	48	14	1055	48	M12	1164	1091

d _o	m	z	x	fz norm	fz max	n1	Pos.
[mm]	[mm]	[-]	[-]	[kN]	[kN]	[-]	
335	5	67	0	18	26	4	1
456	6	76	0	24	35	4	2
558	6	93	0	24	35	4	3
660	6	110	0	24	35	4	4
752	8	94	0	31	47	4	5
856	8	107	0	31	47	4	6
1000	8	125	0	31	47	4	7

* Lager optional mit Zentrierung lieferbar; Außendurchmesser mit -IT8 und Innendurchmesser mit +IT8 toleriert;
* Bearings available with optional centering; outer diameter tolerance -IT8; inner diameter tolerance +IT8;

Zentrierhöhe für Da* und Di* min. 10 mm, für U* min. 4,5 mm
centering height for Da* and Di* min. 10 mm, for U* min. 4,5 mm

Pos.	Tragzahlen / Load ratings			
	statisch / static		dynamisch / dynamic	
	axial C _{0a} [kN]	radial C _{0r} [kN]	axial C _a [kN]	radial C _r [kN]
1	560	248	169	111
2	740	325	188	123
3	880	385	200	131
4	1010	445	211	138
5	1150	510	222	145
6	1280	570	231	151
7	1490	660	244	160

Axialspiel / Axial clearance: 0...0,53 mm**
Radialspiel / Radial clearance: 0...0,3 mm**
** Lager auch mit eingegemtem Spiel oder Vorspannung lieferbar
** Bearings available with restricted internal clearance or preload

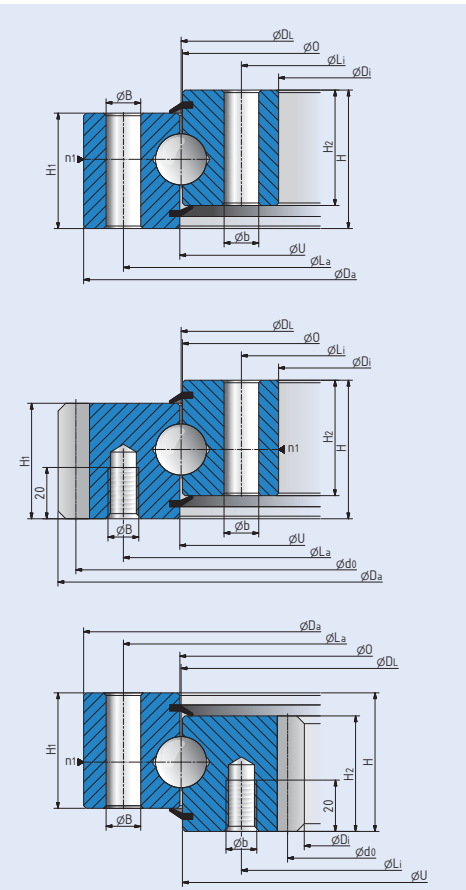

Kugeldrehverbindungen; 1-reihig, Vierpunktlager

Single-row ball slewing bearings, four point contact bearings

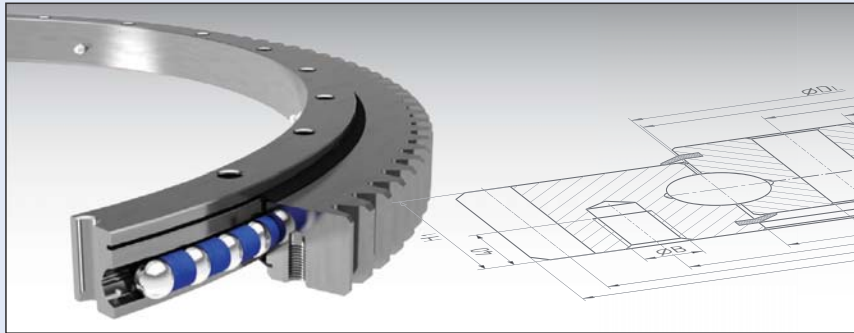

K 1 1 · 2 5 · 0 8 5 5 – Zeichnungsendnummer
 – Drawing end number

Bauform	Laufbahn	Verzahnung	Wälzkörper Ø	Laufkreis Ø
K = Kugel-Drehverbindung L = Leichtbauform, Flanschlager X = Kreuzrollen-Drehverbindung R = Rollen-Drehverbindung	1 = einreihig 2 = zweireihig 3 = dreireihig	0 = ohne 1 = außen gerade 2 = innen gerade 3 = außen schräg 4 = innen schräg	Kugeldurchmesser oder Rollendurchmesser in mm	Durchmesser des Laufkreises in mm
Model	Raceway	Gear	Rolling element Ø	Raceway Ø
K = ball slewing bearing L = light-weight flange bearing X = crossed-roller slewing bearing R = roller slewing bearing	1 = single-row 2 = double-row 3 = triple-row	0 = without gear 1 = outer straight gear 2 = inner straight gear 3 = outer helical gear 4 = inner helical gear	Ball diameter or roller diameter in mm	Diameter of the raceway in mm

Umschlüsseltabelle

Interchange table

Typbezeichnung Type designation	austauschbar mit interchangeable with	
unverzahnt - without gear		
K10.25.0755.810	VSU250755	---
K10.25.0855.810	VSU250855	060.25.0855.500.11.1503
K10.25.0955.810	VSU250955	060.25.0955.500.11.1503
K10.25.1055.810	VSU251055	060.25.1055.500.11.1503
außenverzahnt - external gear		
K11.25.0755.810	VSA250755-N	---
K11.25.0855.810	VSA250855-N	061.25.0855.500.11.1503
K11.25.0955.810	VSA250955-N	061.25.0955.500.11.1503
K11.25.1055.810	VSA251055-N	061.25.1055.500.11.1503
innenverzahnt - internal gear		
K12.25.0755.810	VSI250755-N	---
K12.25.0855.810	VSI250855-N	062.25.0855.500.11.1503
K12.25.0955.810	VSI250955-N	062.25.0955.500.11.1503
K12.25.1055.810	VSI251055-N	062.25.1055.500.11.1503

Kugeldrehverbindungen; 1-reihig, Vierpunktlager

Single-row ball slewing bearings, four point contact bearings

Abmessungen und Gewicht Dimensions and weight									Befestigungsbohrungen Fastening boreholes				Zentrierungen Centerings	
Außendurchmesser Outer diameter	Innendurchmesser Inner diameter	Gesamthöhe Total height	Höhe Außenring Outer ring height	Höhe Innenring Inner ring height	Durchmesser oben Upper diameter	Durchmesser unten Lower diameter	Gewicht Weight	Lochkreisdurchmesser Diam. of borehole circle	Außenring Outer ring		Innenring Inner ring		Zentrierung am Außenring Centering at outer ring	Zentrierung am Innenring Centering at inner ring
									Bohrungsanzahl Number of boreholes	Bohrungsdurchmesser Borehole diameter	Lochkreisdurchmesser Diam. of borehole circle	Bohrungsanzahl Number of boreholes		

Verzahnung und Zahnkräfte Gear and gear tooth forces							Maximal zulässige Zahnkraft Max. permitted gear tooth force	Anzahl der Schmierlippen Number of grease nipples
Teilkreisdurchmesser Pitch circle diameter	Modul Module	Zähnezahl Number of teeth	Profilverschiebungsfaktor Profile shift coefficient	Zulässige Zahnkraft Permitted gear tooth force				

unverzahnt - without gear

Typbezeichnung Type designation	Da	Di	H	H1	H2	O	U	G	La	na	B	Li	ni	b	Da*	Di*
	[mm]	[mm]	[mm]	[mm]	[mm]	[mm]	[mm]	[kg]	[mm]	[-]	[mm]	[mm]	[-]	[mm]	[mm]	[mm]
K10.25.0755.810	855	655	63	54	54	757	753	90	815	24	22	695	24	22	853	657
K10.25.0855.810	955	755	63	54	54	857	853	101	915	28	22	795	28	22	953	757
K10.25.0955.810	1055	855	63	54	54	957	953	115	1015	30	22	895	30	22	1053	857
K10.25.1055.810	1155	955	63	54	54	1057	1053	128	1115	30	22	995	30	22	1153	957

d _o	m	z	x	fz norm	fz max	n1	Pos.
[mm]	[mm]	[-]	[-]	[kN]	[kN]	[-]	
-	-	-	-	-	-	4	1
-	-	-	-	-	-	4	2
-	-	-	-	-	-	4	3
-	-	-	-	-	-	4	4

außenverzahnt - external gear

Typbezeichnung Type designation	Da	Di	H	H1	H2	O	U	G	La	na	B	Li	ni	b	U*	Di*
	[mm]	[mm]	[mm]	[mm]	[mm]	[mm]	[mm]	[kg]	[mm]	[-]	[mm]	[mm]	[-]	[mm]	[mm]	[mm]
K11.25.0755.810	898	655	80	71	54	757	753	128	816	24	M20	695	24	22	755	657
K11.25.0855.810	997	755	80	71	54	857	853	145	916	28	M20	795	28	22	855	757
K11.25.0955.810	1096	855	80	71	54	957	953	155	1016	30	M20	895	30	22	955	857
K11.25.1055.810	1198	955	80	71	54	1057	1053	171	1116	30	M20	995	30	22	1055	957

d _o	m	z	x	fz norm	fz max	n1	Pos.
[mm]	[mm]	[-]	[-]	[kN]	[kN]	[-]	
882	9	98	0	55	80	4	1
981	9	109	0	55	80	4	2
1080	9	120	0	55	80	4	3
1180	10	118	0	61	89	4	4

innenverzahnt - internal gear

Typbezeichnung Type designation	Da	Di	H	H1	H2	O	U	G	La	na	B	Li	ni	b	Da*	U*
	[mm]	[mm]	[mm]	[mm]	[mm]	[mm]	[mm]	[kg]	[mm]	[-]	[mm]	[mm]	[-]	[mm]	[mm]	[mm]
K12.25.0755.810	855	610	80	54	71	753	757	119	815	24	22	694	24	M20	853	755
K12.25.0855.810	955	710	80	54	71	853	857	137	915	28	22	794	28	M20	953	855
K12.25.0955.810	1055	810	80	54	71	953	957	149	1015	30	22	894	30	M20	1053	955
K12.25.1055.810	1155	910	80	54	71	1053	1057	165	1115	30	22	994	30	M20	1153	1055

d _o	m	z	x	fz norm	fz max	n1	Pos.
[mm]	[mm]	[-]	[-]	[kN]	[kN]	[-]	
630	10	63	0	68	99	4	1
730	10	73	0	68	99	4	2
830	10	83	0	68	99	4	3
930	10	93	0	68	99	4	4

* Lager optional mit Zentrierung lieferbar; Außendurchmesser mit -IT8 und Innendurchmesser mit +IT8 toleriert;
* Bearings available with optional centering; outer diameter tolerance -IT8; inner diameter tolerance +IT8;

Zentrierhöhe für Da*, Di* und U* min. 15 mm
centering height for Da*, Di* and U* min. 15 mm

Tragzahlen / Load ratings				
Pos.	statisch / static		dynamisch / dynamic	
	axial	radial	axial	radial
	C _{0a} [kN]	C _{0r} [kN]	C _a [kN]	C _r [kN]
1	2250	1010	460	300
2	2550	1150	485	315
3	2850	1280	500	330
4	3150	1410	520	340

Axialspiel / Axial clearance: 0,05...0,24 mm**
Radialspiel / Radial clearance: 0,03...0,13 mm**
** Lager auch mit eingegtem Spiel oder Vorspannung lieferbar
** Bearings available with restricted internal clearance or preload

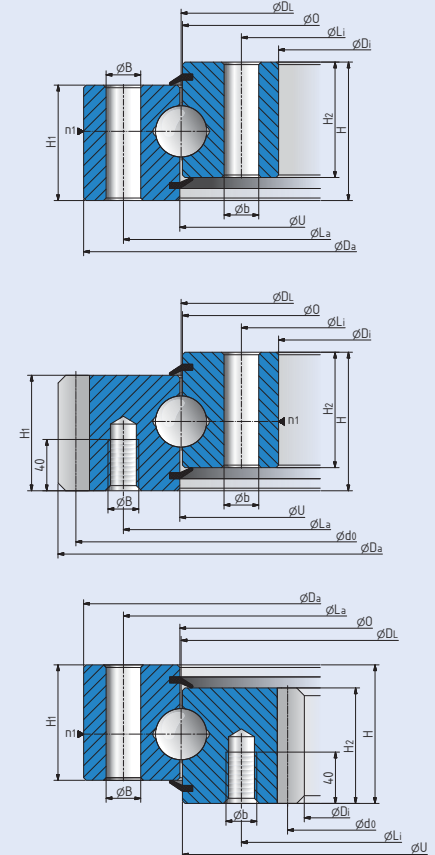

Kreuzrollen-Drehverbindungen Crossed-roller slewing bearings

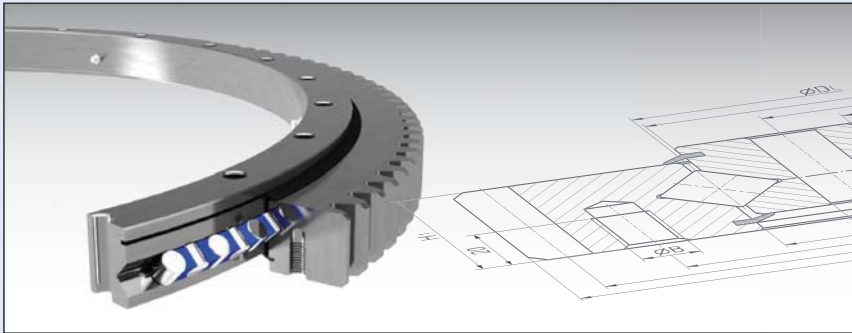

X 1 1 · 1 4 · 0 4 1 4 – Zeichnungsendnummer
– Drawing end number

Bauform	Laufbahn	Verzahnung	Wälzkörper Ø	Laufkreis Ø
K = Kugel-Drehverbindung L = Leichtbauform, Flanschlager X = Kreuzrollen-Drehverbindung R = Rollen-Drehverbindung	1 = einreihig 2 = zweireihig 3 = dreireihig	0 = ohne 1 = außen gerade 2 = innen gerade 3 = außen schräg 4 = innen schräg	Kugeldurchmesser oder Rollendurchmesser in mm	Durchmesser des Laufkreis in mm
Model	Raceway	Gear	Rolling element Ø	Raceway Ø
K = ball slewing bearing L = light-weight flange bearing X = crossed-roller slewing bearing R = roller slewing bearing	1 = single-row 2 = double-row 3 = triple-row	0 = without gear 1 = outer straight gear 2 = inner straight gear 3 = outer helical gear 4 = inner helical gear	Ball diameter or roller diameter in mm	Diameter of the raceway in mm

Umschlüsseltabelle Interchange table

Typbezeichnung Type designation	austauschbar mit interchangeable with	
unverzahnt - without gear		
X10.14.0414.810	XSU140414	---
X10.14.0544.810	XSU140544	---
X10.14.0644.810	XSU140644	---
X10.14.0744.810	XSU140744	---
X10.14.0844.810	XSU140844	---
X10.14.0944.810	XSU140944	---
X10.14.1094.810	XSU141094	---
außenverzahnt - external gear		
X11.14.0414.810	XSA140414-N	---
X11.14.0544.810	XSA140544-N	---
X11.14.0644.810	XSA140644-N	---
X11.14.0744.810	XSA140744-N	---
X11.14.0844.810	XSA140844-N	---
X11.14.0944.810	XSA140944-N	---
X11.14.1094.810	XSA141094-N	---
innenverzahnt - internal gear		
X12.14.0414.810	XSI140414-N	---
X12.14.0544.810	XSI140544-N	---
X12.14.0644.810	XSI140644-N	---
X12.14.0744.810	XSI140744-N	---
X12.14.0844.810	XSI140844-N	---
X12.14.0944.810	XSI140944-N	---
X12.14.1094.810	XSI141094-N	---

Kreuzrollen-Drehverbindungen

Crossed-roller slewing bearings

Abmessungen und Gewicht Dimensions and weight								Befestigungsbohrungen Fastening boreholes				Laufgenauigkeit Running accuracy	
Außendurchmesser Outer diameter	Innendurchmesser Inner diameter	Gesamthöhe Total height	Höhe Außenring Outer ring height	Höhe Innenring Inner ring height	Durchmesser oben Upper diameter	Durchmesser unten Lower diameter	Gewicht Weight	Außenring Outer ring		Innenring Inner ring		Planlauf des Außen- und Innenring Axial runout of outer and inner ring	Rundlauf des Außen- und Innenring Radial runout of outer and inner ring
								Lochkreisdurchmesser Diam. of borehole circle	Bohrungsanzahl Number of boreholes	Bohrungsdurchmesser Borehole diameter	Lochkreisdurchmesser Diam. of borehole circle		

Verzahnung und Zahnkräfte Gear and gear tooth forces						
Teilkreisdurchmesser Pitch circle diameter	Modul Module	Zähnezahl Number of teeth	Profilverschiebungsfaktor Profile shift coefficient	Zulässige Zahnkraft Permitted gear tooth force	Maximal zulässige Zahnkraft Max. permitted gear tooth force	Anzahl der Schmiernippel Number of grease nipples

unverzahnt - without gear

Typbezeichnung Type designation	Da*	Di*	H	H1	H2	O	U	G	La	na	B	Li	ni	b	axial	radial
	[mm]	[mm]	[mm]	[mm]	[mm]	[mm]	[mm]	[kg]	[mm]	[-]	[mm]	[mm]	[-]	[mm]	[mm]	[mm]
X10.14.0414.810	484	344	56	44,5	44,5	413	415	28	460	24	14	368	24	14	0,04	0,06
X10.14.0544.810	614	474	56	44,5	44,5	543	545	38	590	32	14	498	32	14	0,04	0,07
X10.14.0644.810	714	574	56	44,5	44,5	643	645	44	690	36	14	598	36	14	0,05	0,08
X10.14.0744.810	814	674	56	44,5	44,5	743	745	52	790	40	14	698	40	14	0,05	0,09
X10.14.0844.810	914	774	56	44,5	44,5	843	845	60	890	40	14	798	40	14	0,06	0,09
X10.14.0944.810	1014	874	56	44,5	44,5	943	945	67	990	44	14	898	44	14	0,06	0,11
X10.14.1094.810	1164	1024	56	44,5	44,5	1093	1095	77	1140	48	14	1048	48	14	0,07	0,11

d _o	m	z	x	fz norm	fz max	n1	Pos.
[mm]	[mm]	[-]	[-]	[kN]	[kN]	[-]	
-	-	-	-	-	-	4	1
-	-	-	-	-	-	4	2
-	-	-	-	-	-	4	3
-	-	-	-	-	-	4	4
-	-	-	-	-	-	4	5
-	-	-	-	-	-	4	6
-	-	-	-	-	-	4	7

außenverzahnt - external gear

Typbezeichnung Type designation	Da	Di*	H	H1	H2	O	U*	G	La	na	B	Li	ni	b	axial	radial
	[mm]	[mm]	[mm]	[mm]	[mm]	[mm]	[mm]	[kg]	[mm]	[-]	[mm]	[mm]	[-]	[mm]	[mm]	[mm]
X11.14.0414.810	503,3	344	56	44,5	44,5	413	417	32	455	20	M12	368	24	14	0,04	0,06
X11.14.0544.810	640,3	474	56	44,5	44,5	543	547	44	585	28	M12	498	32	14	0,04	0,07
X11.14.0644.810	742,3	574	56	44,5	44,5	643	647	52	685	32	M12	598	36	14	0,05	0,08
X11.14.0744.810	838,1	674	56	44,5	44,5	743	747	59	785	36	M12	698	40	14	0,05	0,08
X11.14.0844.810	950,1	774	56	44,5	44,5	843	847	71	885	36	M12	798	40	14	0,05	0,09
X11.14.0944.810	1046,1	874	56	44,5	44,5	943	947	77	985	40	M12	898	44	14	0,06	0,09
X11.14.1094.810	1198,1	1024	56	44,5	44,5	1093	1097	91	1135	44	M12	1048	48	14	0,07	0,11

d _o	m	z	x	fz norm	fz max	n1	Pos.
[mm]	[mm]	[-]	[-]	[kN]	[kN]	[-]	
495	5	99	0	16	24	4	1
630	6	105	0	21	32	4	2
732	6	122	0	21	32	4	3
828	6	138	0	21	32	4	4
936	8	117	0	28	42	4	5
1032	8	129	0	28	42	4	6
1184	8	148	0	28	42	4	7

innenverzahnt - internal gear

Typbezeichnung Type designation	Da*	Di	H	H1	H2	O	U*	G	La	na	B	Li	ni	b	axial	radial
	[mm]	[mm]	[mm]	[mm]	[mm]	[mm]	[mm]	[kg]	[mm]	[-]	[mm]	[mm]	[-]	[mm]	[mm]	[mm]
X12.14.0414.810	484	325	56	44,5	44,5	415	411	31	460	24	14	375	24	M12	0,04	0,06
X12.14.0544.810	614	444	56	44,5	44,5	545	541	43	590	32	14	505	32	M12	0,04	0,07
X12.14.0644.810	714	546	56	44,5	44,5	645	641	50	690	36	14	605	36	M12	0,05	0,08
X12.14.0744.810	814	648	56	44,5	44,5	745	741	58	790	40	14	705	40	M12	0,05	0,09
X12.14.0844.810	914	736	56	44,5	44,5	845	841	69	890	40	14	805	40	M12	0,06	0,09
X12.14.0944.810	1014	840	56	44,5	44,5	945	941	76	990	44	14	905	44	M12	0,06	0,11
X12.14.1094.810	1164	984	56	44,5	44,5	1095	1091	91	1140	48	14	1055	48	M12	0,07	0,11

d _o	m	z	x	fz norm	fz max	n1	Pos.
[mm]	[mm]	[-]	[-]	[kN]	[kN]	[-]	
335	5	67	0	18	26	4	1
456	6	76	0	24	35	4	2
558	6	93	0	24	35	4	3
660	6	110	0	24	35	4	4
752	8	94	0	31	47	4	5
856	8	107	0	31	47	4	6
1000	8	125	0	31	47	4	7

* Lager grundsätzlich mit Zentrierung; Außendurchmesser mit -IT7 und Innendurchmesser mit +IT7 toleriert;
* Bearings always with centering; outer diameter tolerance -IT7; inner diameter tolerance +IT7;

Zentrierhöhe für Da* und Di* min. 10 mm, für U* min. 4,5 mm
centering height for Da* and Di* min. 10 mm, for U* min. 4,5 mm

Pos.	Tragzahlen / Load ratings			
	statisch / static		dynamisch / dynamic	
	axial C _{0a} [kN]	radial C _{0r} [kN]	axial C _a [kN]	radial C _r [kN]
1	520	250	229	146
2	680	330	270	170
3	800	395	290	185
4	930	455	315	200
5	1050	510	340	215
6	1170	580	360	227
7	1360	670	390	246

Lager grundsätzlich vorgespannt
Bearings always preloaded

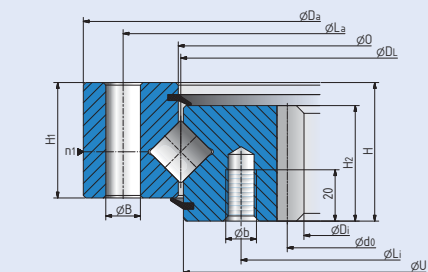
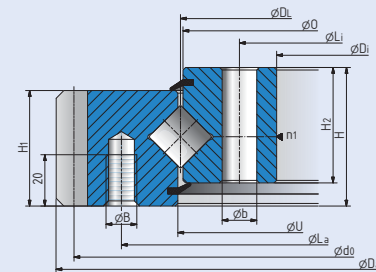
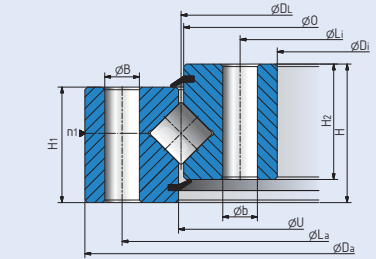

So finden Sie uns - How to find us

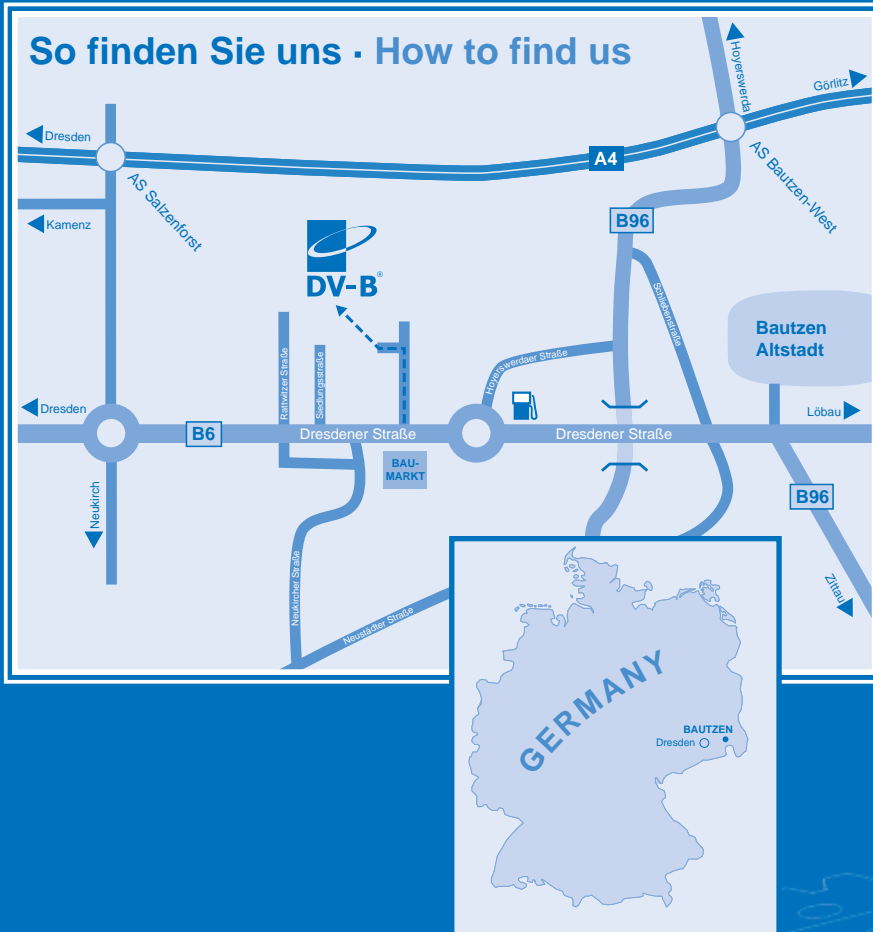

DV-B Drehverbindungen
Bautzen GmbH
Dresdener Straße 88
D - 02625 Bautzen
Germany

Phone +49 3591 270 88 80
Fax +49 3591 270 88 88

www.dv-b.com
sales@dv-b.com