

New wheel stud for ECO Air COMPACT with disc brake (ET 120 mm)

With its new ECO Air COMPACT air suspension, BPW is also introducing a new wheel stud for the disc-braked ECO Disc TSB 3709 and TSB 4309 with ET 120 designs.

In ECO Air COMPACT with drum brake and ET 0 the wheel studs remain unchanged.

The new wheel stud has a length of 93 mm and can be used with all currently available forged aluminium wheels and steel wheels for single wheels. That means that it is approved for wheel discs with a wheel centre thickness of up to 28mm.

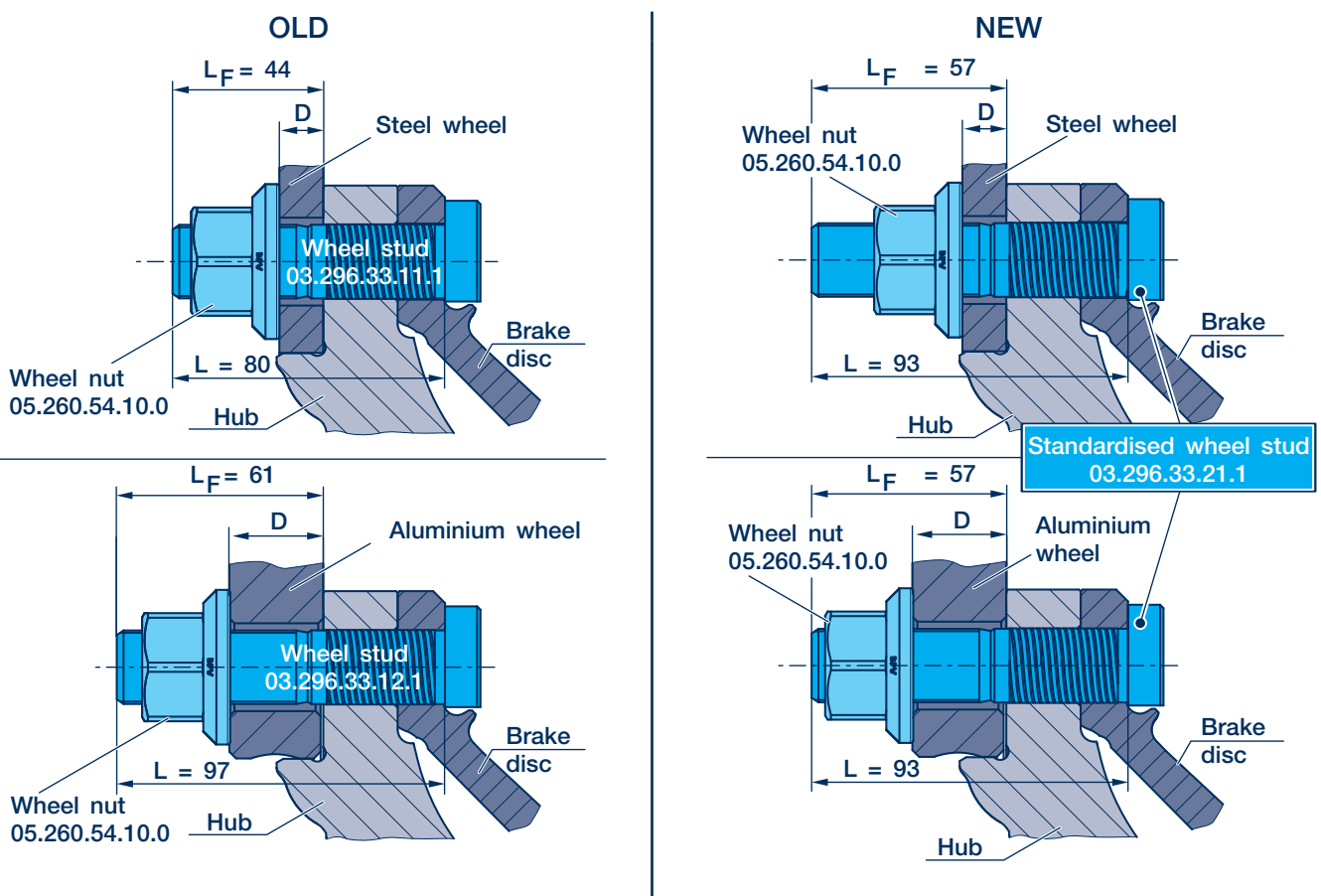

Code number of wheel stud	Length L	Length L_F	Wheels for single wheels			
			Steel	Alu \varnothing 26 mm $D \leq 28$ mm	Alu \varnothing 26 mm $D \geq 28$ mm	Alu \varnothing 32 mm
03.296.33.21.1	93 mm	57 mm	yes	yes	no *	yes **

* can be done with longer wheel studs

** only possible with sleeve nuts

Following the introduction of ECO Air COMPACT, the wheel stud will also be introduced from 2013 for the disc-braked Airlight II with ET 120 designs.

Note:

In the case of older wheels with a wheel centre thickness greater than 28 mm, BPW offers correspondingly longer wheel studs (03.296.33.12.1). For wheel with stud hole diameters of 32 mm, BPW supplies corresponding sleeve nuts (05.260.5.21.1).

Please contact your BPW contact partner if you require any further information.