

New products: Self-steering axle with TSB 4312

LL axle SMSFHLL 12010 ECO Plus

Self-steering axle with TSB 4312

Self-steering axle with TSB 4312 has been especially developed for an extended application of up to 12 t.

- Tonnage 12t
- Suitable for diaphragm cylinder type 16/18/20/22/24
- For 425/65 R22.5 tyres with 22.5 x 13.00 rim
- Track (SP) 2035
- Spring centres (LM) 980
- Shock absorber centres 738
- Braking position 30° bottom rear
- Steering angle (factory setting) 12°
- With ABS
- Draglink position 312/171 top
- Axle beam 120 solid

Series production has started.

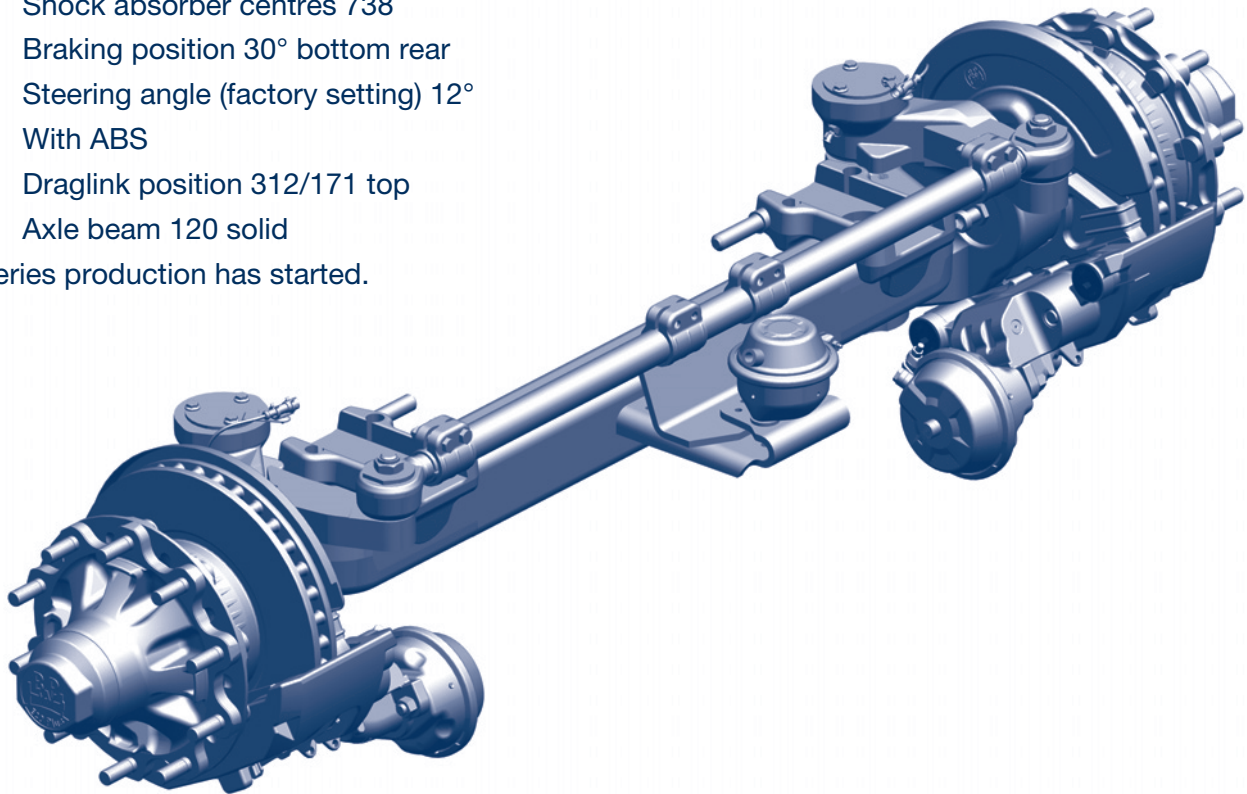

ECE - R79 certificate

Certificate for 1:1 approval for BPW self-steering axles

Revised certificate RDW-R79-0006828 according to ECE - R79 can be found at <http://www.bpw.de/de/support/downloads/gutachten.html>

It includes 1:1 approval (if applicable) for BPW LL axles.

This is an approval for a trailer with one LL axle and one rigid axle or two rigid axles with one lift axle according to the current certificates.