



EA3853RM RECYCLING LID

WITH RAIN HOOD. TO FIT 2.5 AND 5m³ EURO CONTAINERS.

LIGHTWEIGHT - ROBUST - USER FRIENDLY - COST EFFICIENT

3 hinges designed for **extra strength.**

Equipped to accept **patented CCE lock for security.**

Hinges are designed to **interlock** when lids are placed back to back.

5 ribs for **optimal strength.**

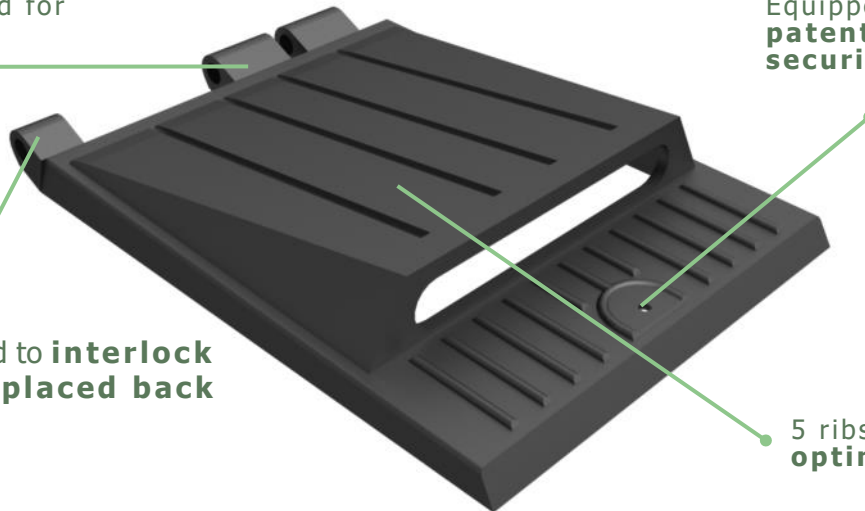

With an open aperture for collection of paper.

TECHNICAL DIMENSIONS

OPTIONS

> Also available as a **standard version** (EA3853) and an **overlapping watertight pair** (EA3853MM&SM).

MATERIAL

> Rotationally moulded from **UV - stabilized LMDPE**; **double-walled**; oil, chemical and frost **resistant**; **100% recyclable.**

COLOURS

> Available in **black** and a **wide variety of colours.**

