

BECKHOFF New Automation Technology

PC-based control for robotics in
handling, production and assembly

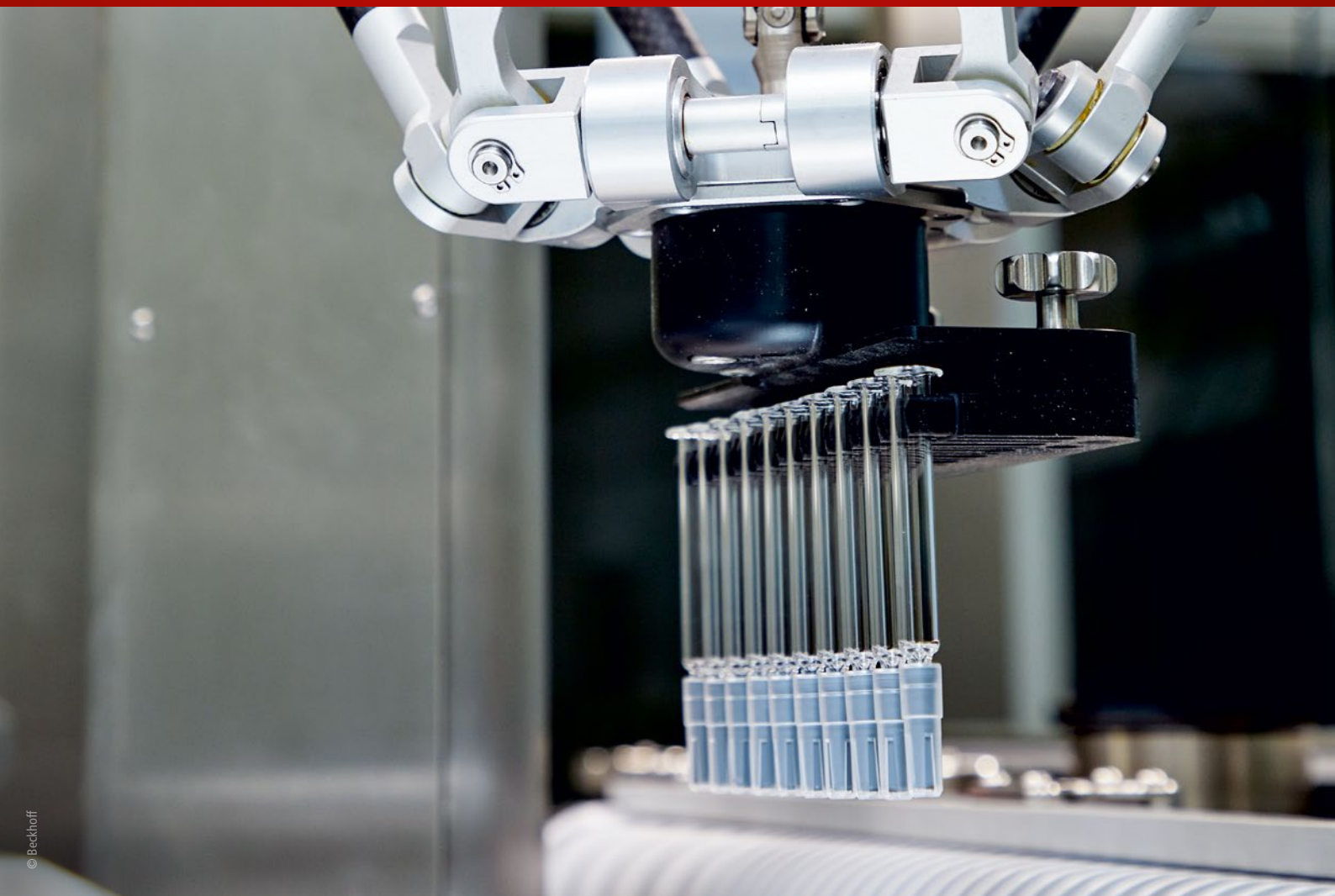

PC-based control integrates all control functions on one platform

The PC- and EtherCAT-based control solution from Beckhoff is ideally suited for automating all applications in the areas of feeding, assembly, testing and handling. The integrated hardware and software platform consists of an Industrial PC, the fast EtherCAT fieldbus with distributed I/Os, a comprehensive portfolio of drive technology components and TwinCAT, the software platform for engineering, sequence control, simulation and diagnostics. Based on the high performance of multi-core and many-core processors, the software is able to execute control functions such as PLC, HMI, motion control, safety technology, robotics

and measurement technology on a central IPC hardware.

Open hardware and software interfaces, support for all common fieldbus systems and software protocols and integrated IoT connectivity enable continuous communication from the field level to the cloud. TwinCAT handles all control tasks: from simple PLC functionalities through to the calculation of complex mathematical algorithms for analyzing measured values or for robot kinematics. With seamless integration of image processing and robotics into machine control, high dynamics and repeatability can be achieved. At

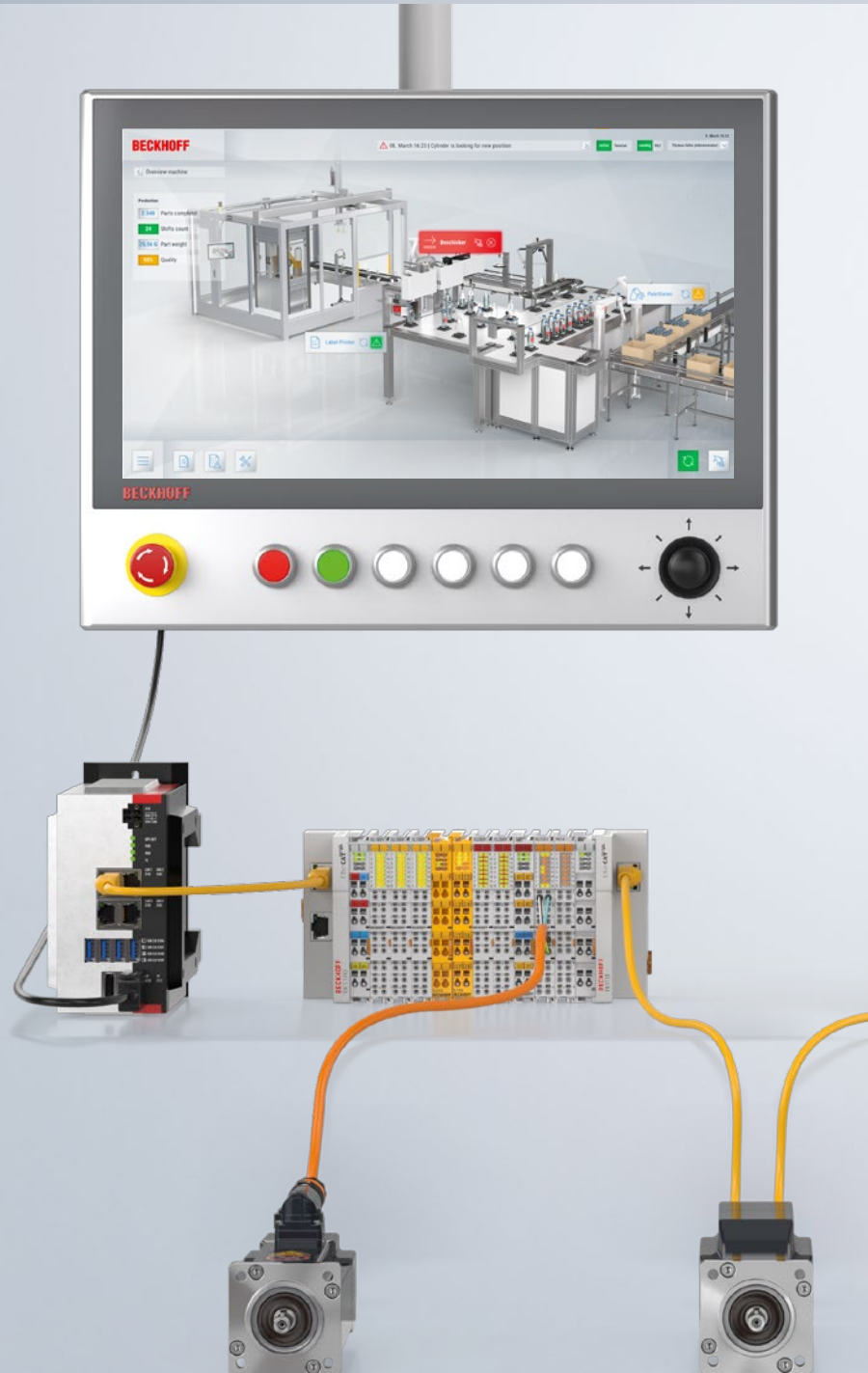

the same time, hardware costs are reduced as well as the effort for engineering, cabling and stock management. With measurement terminals, it is possible to integrate condition monitoring and energy data management functions in compliance with the ISO 50001 standard. The data is captured in the EtherCAT Terminal system and processed in the central control system. Large volumes of data can be stored, managed and analyzed in the edge level or in the cloud using TwinCAT IoT and TwinCAT Analytics.



© Beckhoff

Feeding, page 6



© Beckhoff

Assembly, page 7



© KUKA Roboter

Inspection, page 8



© IMA Meintert

Handling, page 9

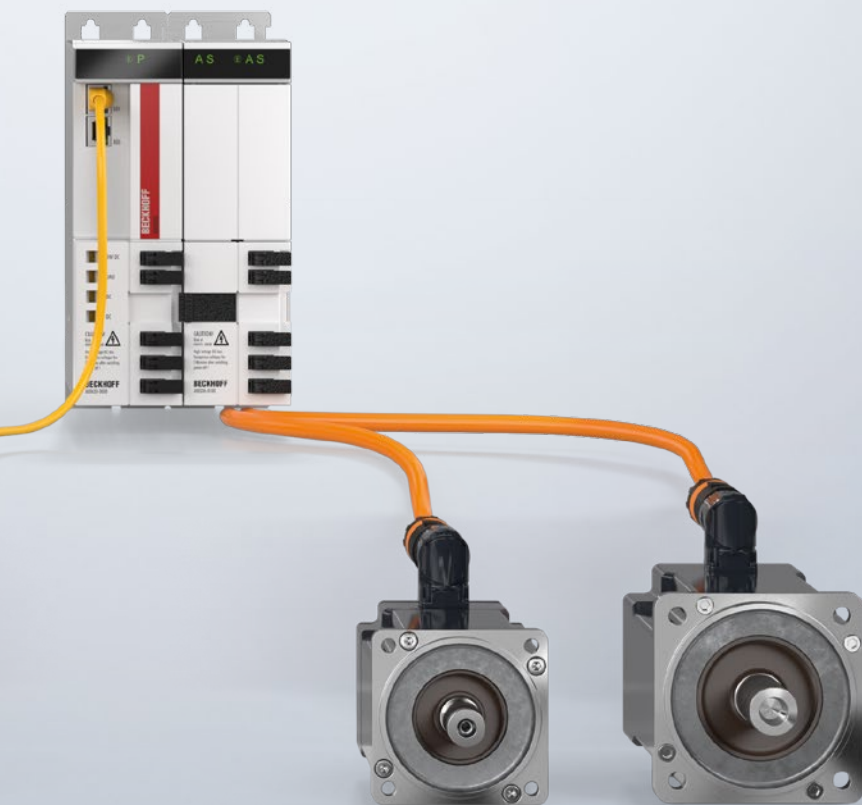

One system approach: From single machines to complete production lines

AMP8000:
distributed servo drive systems for machine concepts without control cabinets

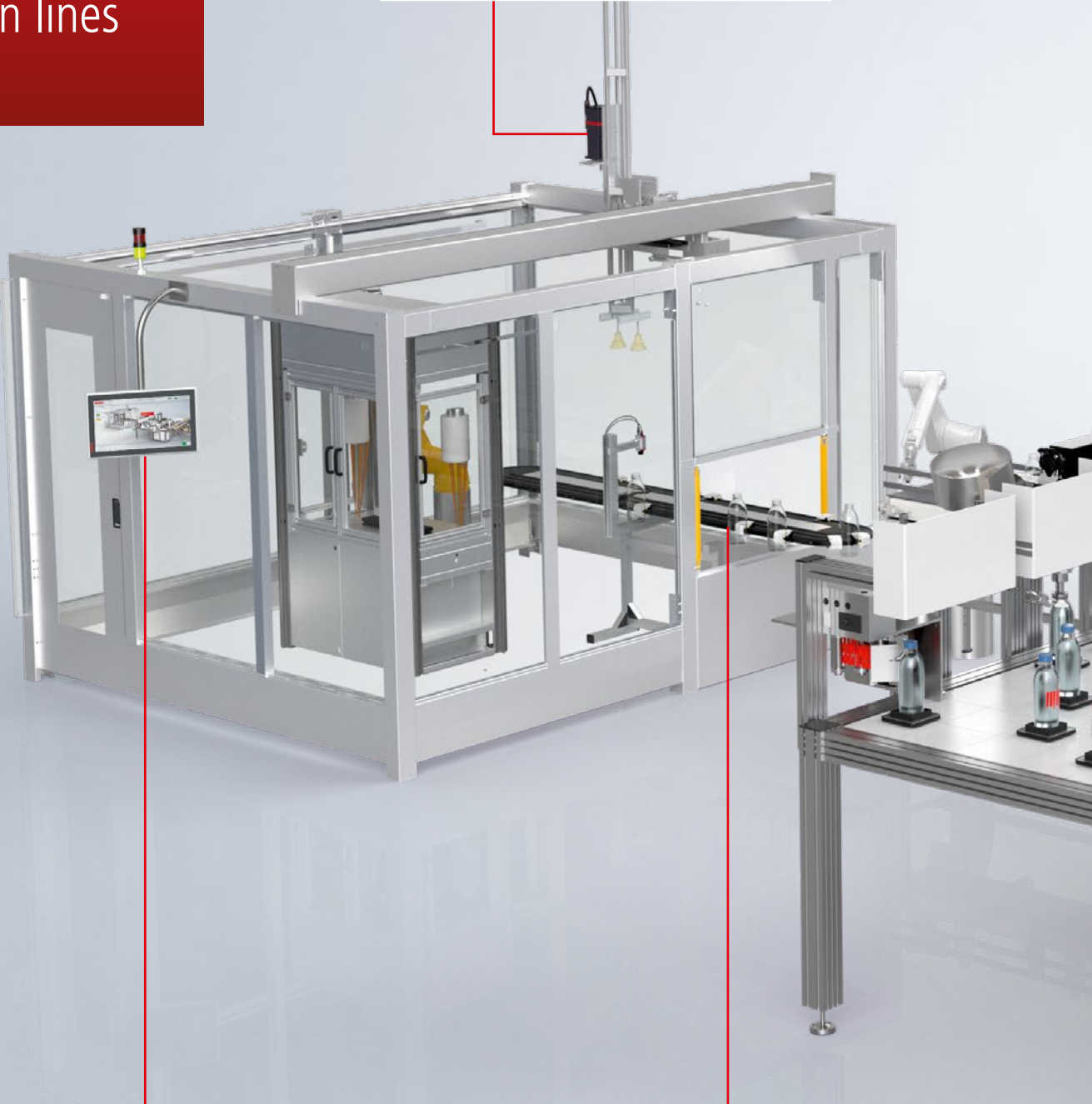

Industrial PCs:
control cabinet and Panel PCs for all control requirements



XTS:
intelligent product transport system for innovative machine concepts



TwinCAT Vision:
integrated image
processing for quality
control of transported
goods in real time



C7015:
ultra-compact
Industrial PC with
IP65 protection rating
for direct integration
into the machine



**TwinCAT Kinematic
Transformation:**
integration of robotics
into the control
platform



XPlanar:
levitating transport
system for optimum
flexibility in product
handling

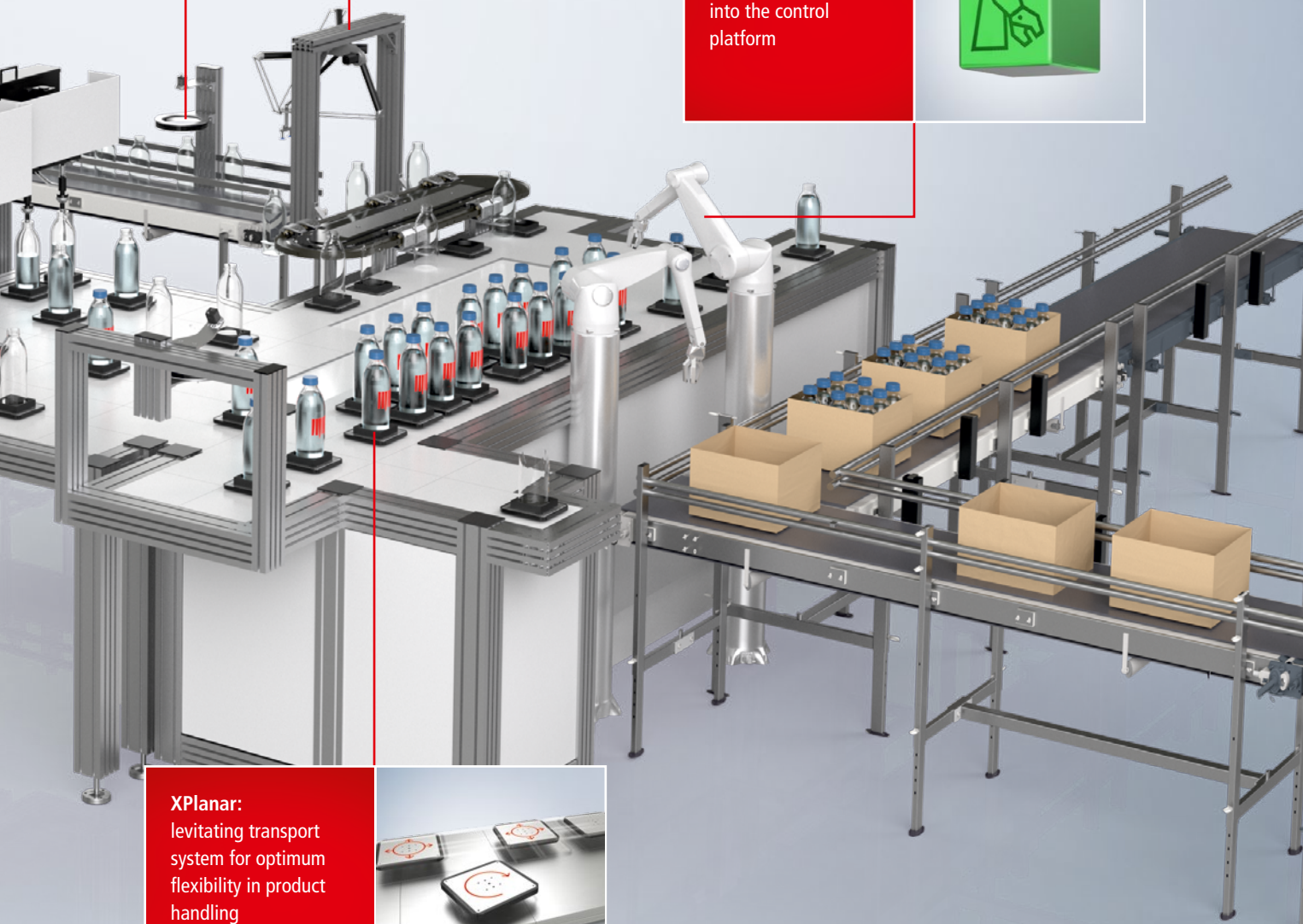

Example configuration for feeding processes

The synchronous movement of multiple coupled axes is one of the strengths of PC- and EtherCAT-based control technology from Beckhoff. Drive control for point-to-point movements is implemented in software with TwinCAT NC PTP. The ultra-compact IP65-rated C7015 Industrial PC can be integrated directly into the machine requiring only minimal installation space. With CP-Link 4, a distance of up to 100 m can be bridged between a Control Panel and PC because the One Cable Display Link transmits video signals, USB 2.0 and power supply via a Cat.6A cable. The AX8000 multi-axis servo system allows for implementation

of space-saving solutions, which can be used, for example, for controlling a three-axis gantry portal.

The wide range of interfaces supported by our I/O system means that other fieldbus systems can be integrated. The integrated safety solution TwinSAFE helps achieve significant advantages in terms of planning, installation, operation, maintenance and diagnostics. It also reduces costs considerably.

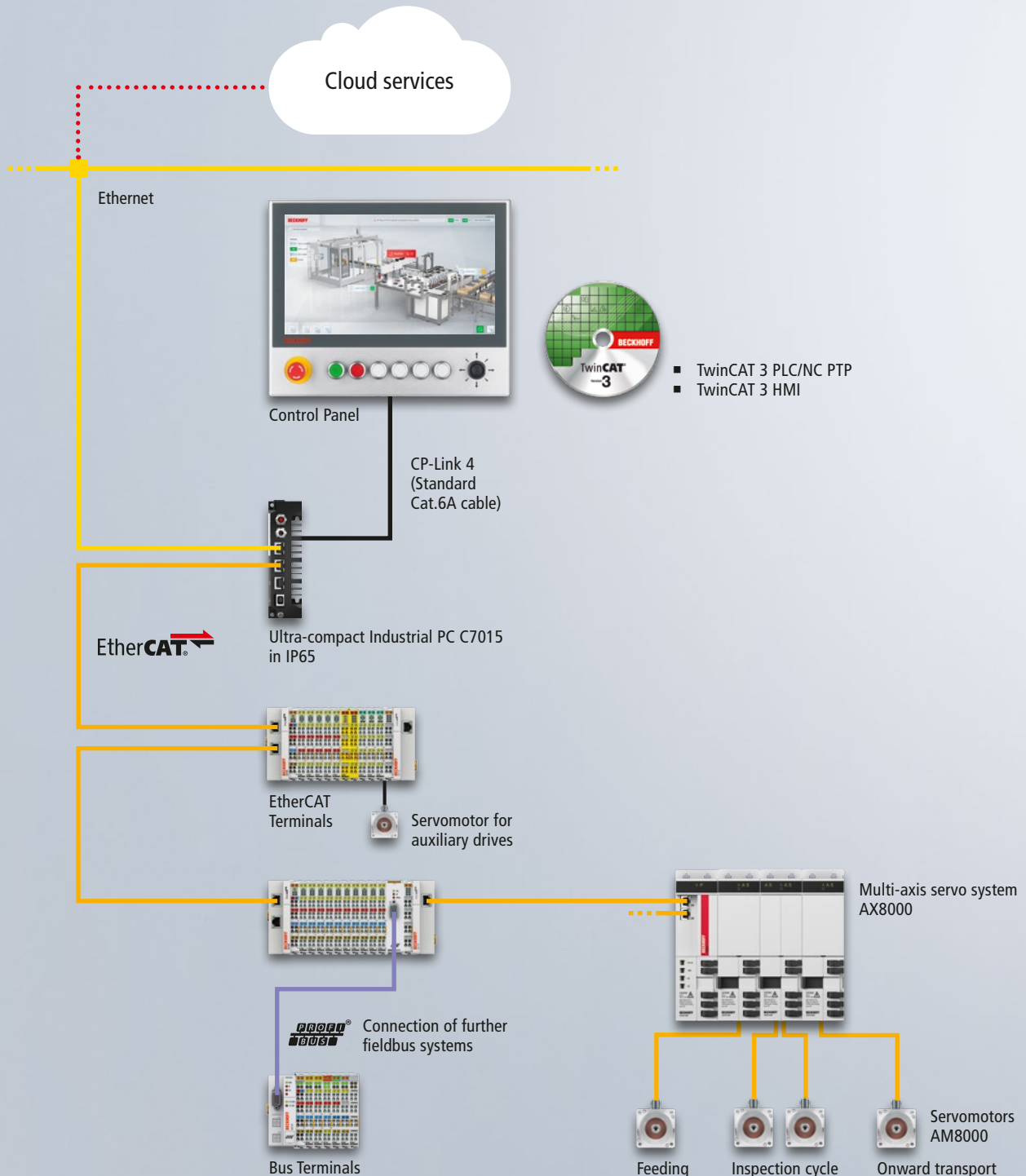

Example configuration for assembly processes

Gantry robots or articulated robots are frequently used in assembly steps such as joining, gluing, screwing or welding. The quality of the production process and the finished products is impacted significantly by factors such as determinism and equidistant timing in signal processing. Here, the EtherCAT high-speed communication system comes into play: the distributed clocks and oversampling functions in EtherCAT enable highest levels of precision and repeat accuracy for controlling diverse processes. In addition, the EtherCAT Hot Connect functionality enables fast tool changes.

The C6032 Industrial PC is a high-performance control system in an ultra-compact design. Equipped with an Intel® Core™-i processor, the C6032 is suitable for highly complex automation and visualization tasks. Also applications for vision and robotics, high-volume data handling and IoT applications can be realized on the same hardware.

Connected with a one-cable solution, the robust EtherCAT P modules can be integrated directly into the machine, saving space in the control cabinet and reducing the cabling effort. Specific TwinCAT software modules support direct communication via robot interfaces such as uniVAL PLC (Stäubli) or KRC4 (KUKA).

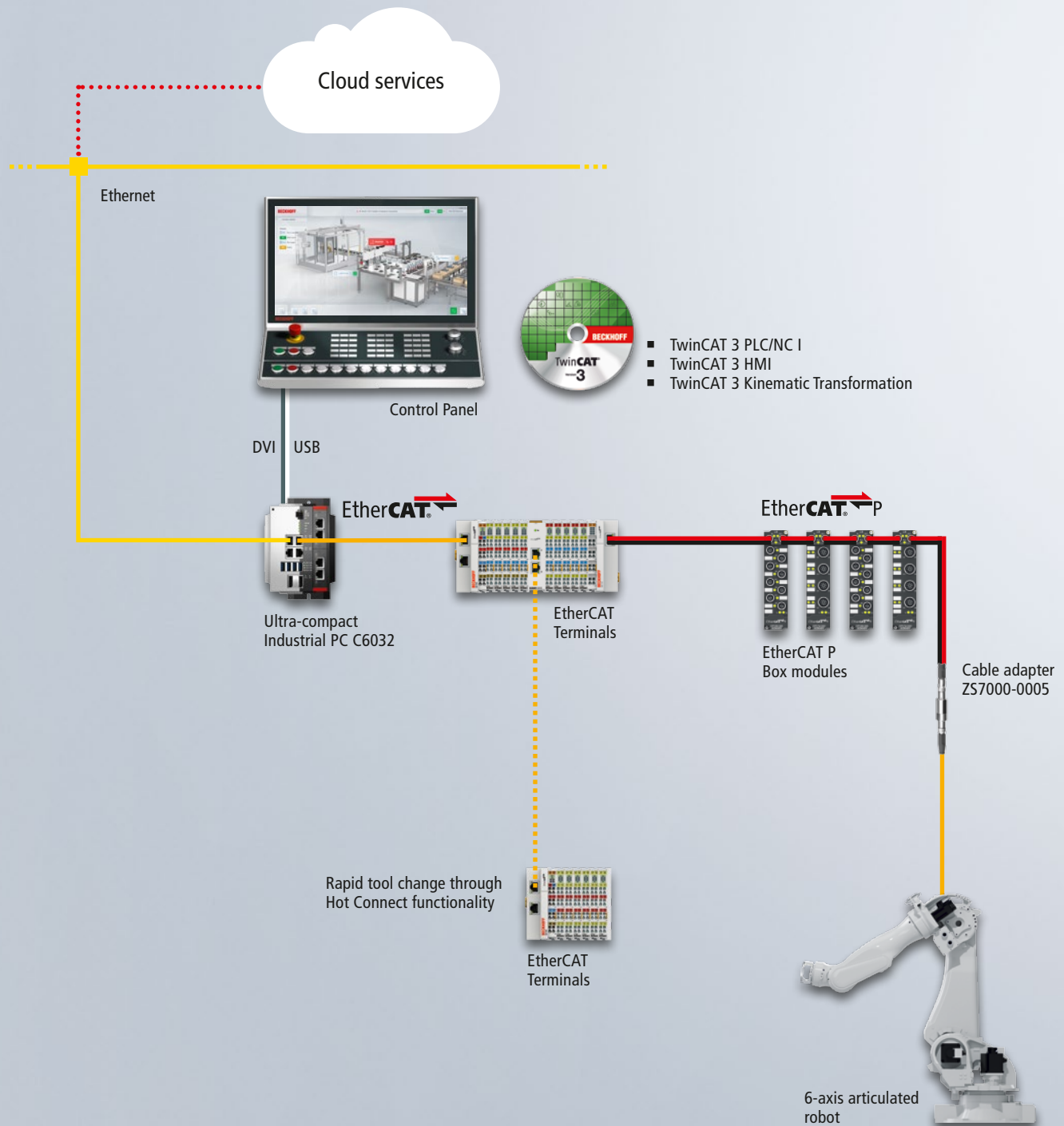

Example configuration for inspection processes

A key requirement for consistent production quality is the integration of suitable inspection systems into the production process. With eXtreme Fast Control Technology (XFC), we offer a control technology that enables very fast and highly deterministic responses – an essential requirement for test and inspection systems.

Interface terminals allow a multitude of peripherals, such as cameras or weighing scales, to be integrated into the controller. Consistent quality inspection is possible with a comprehensive portfolio of measurement terminals as well as integration of image processing with TwinCAT Vision.

Motion control solutions for feeding, lifting, rotating, tilting and discharging products can be implemented in a space-saving manner with the AMP8000 distributed drive system, which integrates the servo drive into the servomotor. This reduces the space required in the control cabinet to a single coupling module (AX883x), which supplies several servo drives with only one cable via a distribution module (AMP8800). As a result, the footprint of your system is reduced and new possibilities are created for implementing modular machine concepts.

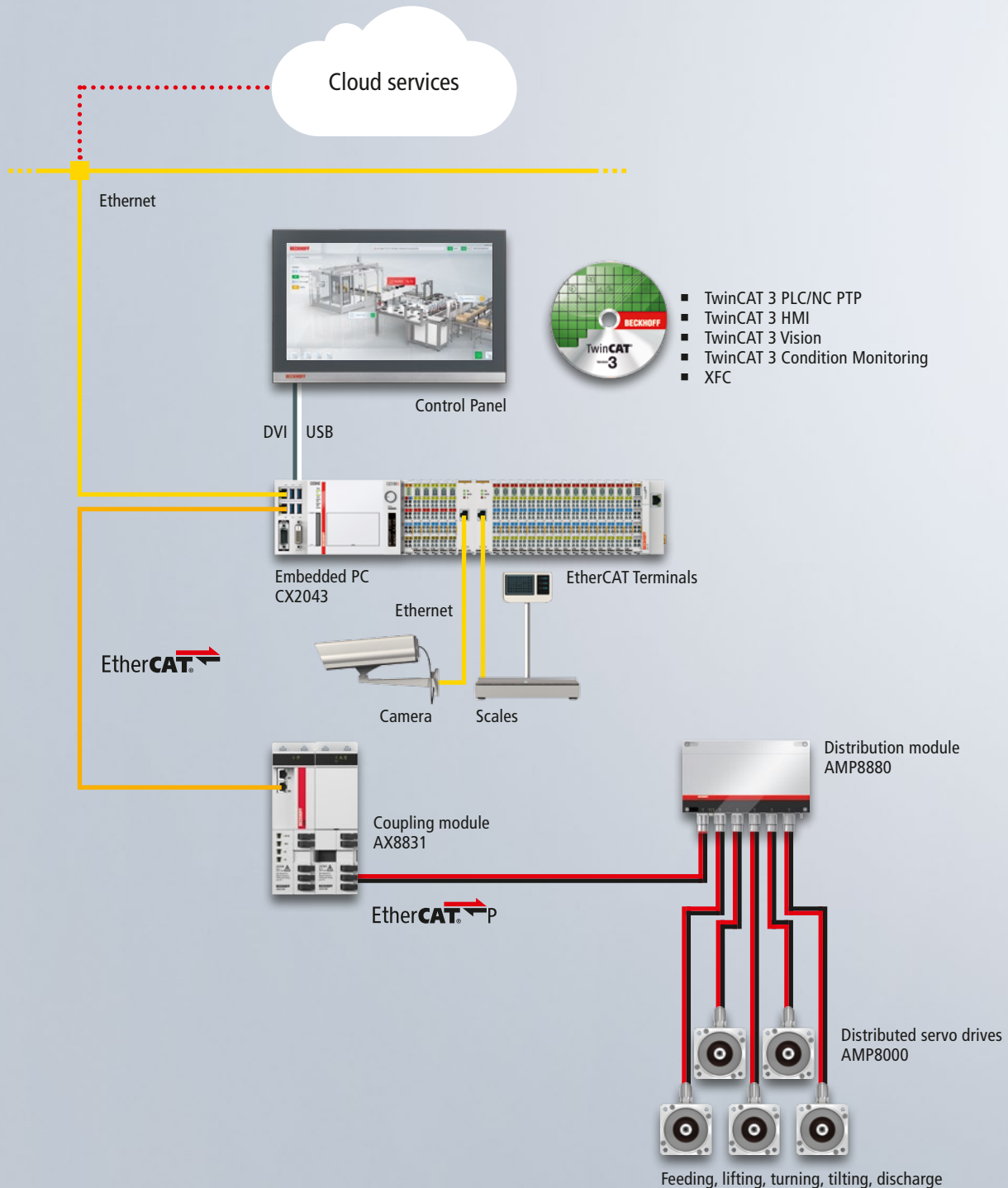

Example configuration for handling systems

Intelligent transport systems, such as our XPlanar planar motor system and the eXtended Transport System XTS replace inflexible product transport systems and enable new and efficient machine designs. Their optimum speed and flexibility create a distinct competitive edge in the global marketplace. Moreover, due to their space-saving design, these technologies reduce the footprint of your machine. And when it comes to achieving innovative machine and product design, the possibilities are limitless.

The free-floating planar movers of the XPlanar system open up new fields of technology, for example, in product handling with the strictest

hygiene requirements: because liquids can be moved without spilling over and the motion of the movers causes no friction, contamination can be avoided. With six degrees of freedom, XPlanar removes all limitations for a flexible positioning of products or tools.

The control of the floating tiles requires the use of EtherCAT G for the communication and for the execution of machine learning algorithms in the controller.

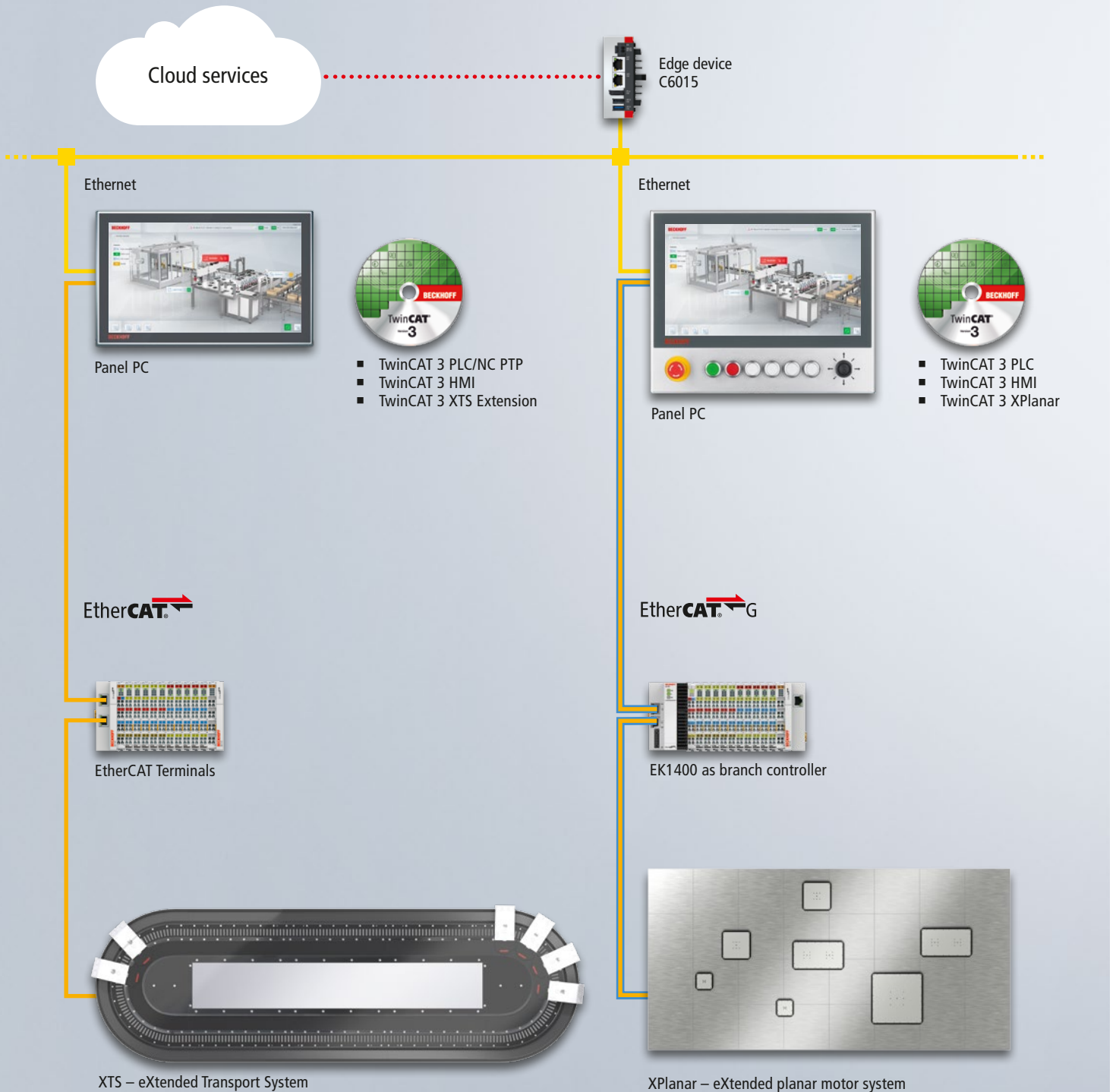

From the sensor to the cloud: IoT and Industrie 4.0 with PC-based control technology

We developed the TwinCAT IoT connectivity product family for communication between machine controllers and cloud-based services. It supports the standardized OPC UA, AMQP, MQTT and HTTPS protocols for communication with common cloud systems such as Microsoft Azure™, Amazon Web Services and private cloud systems in enterprise networks. TwinCAT IoT is quick and easy to configure and, together with an Industrial PC or Embedded PC as the IoT controller, establishes a seamless connection between the Internet of Things and the Internet of Services. Integrated security mechanisms prevent misuse of data as a result of unautho-

rized access and protect the intellectual property of your company.

With the TwinCAT Analytics Library, process data is recorded and analyzed synchronously with the machine cycle and can be used for predictive maintenance and machine optimization purposes, to name just two examples. Using appropriate analysis tools, all necessary information can be derived from the stored data in order to optimize your machine in terms of energy efficiency or process workflow. Post-mortem analysis, intermittent fault diagnostics and the early detection of quality shortfalls and production bottlenecks improve your equipment's reliability and availability. Data

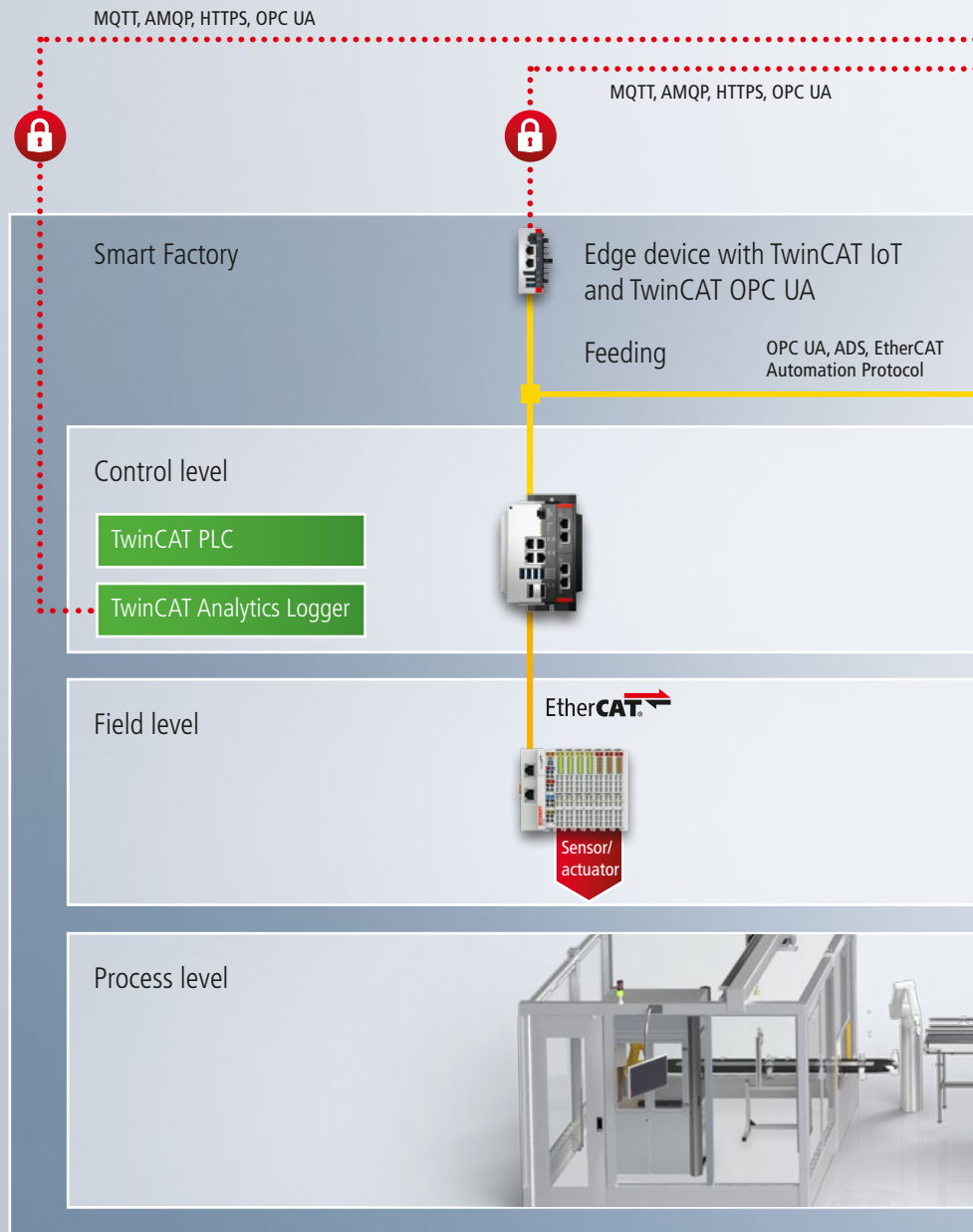

analysis can also provide you with comprehensive information about the operational performance of your machines, which you can use in future design and production processes to reduce costs and create ideal machine layouts.

However, Beckhoff technology also supports the upgrading of existing machines and systems. Different hardware and software products are available for retrofits, such as the ultra-compact C6015 Industrial PC with OPC UA interface, which can be integrated subsequently into an existing control cabinet to enable connection to the cloud. Depending on the application, the solution can also be used as an edge device for data prepro-

cessing or concentration and data transmission. The EK9160 IoT Coupler is available for directly capturing digital and analog process values. It is especially suitable for retrofitting machines and allows simple transmission of data to higher-level systems via MQTT or OPC UA by means of preconfigured network access.

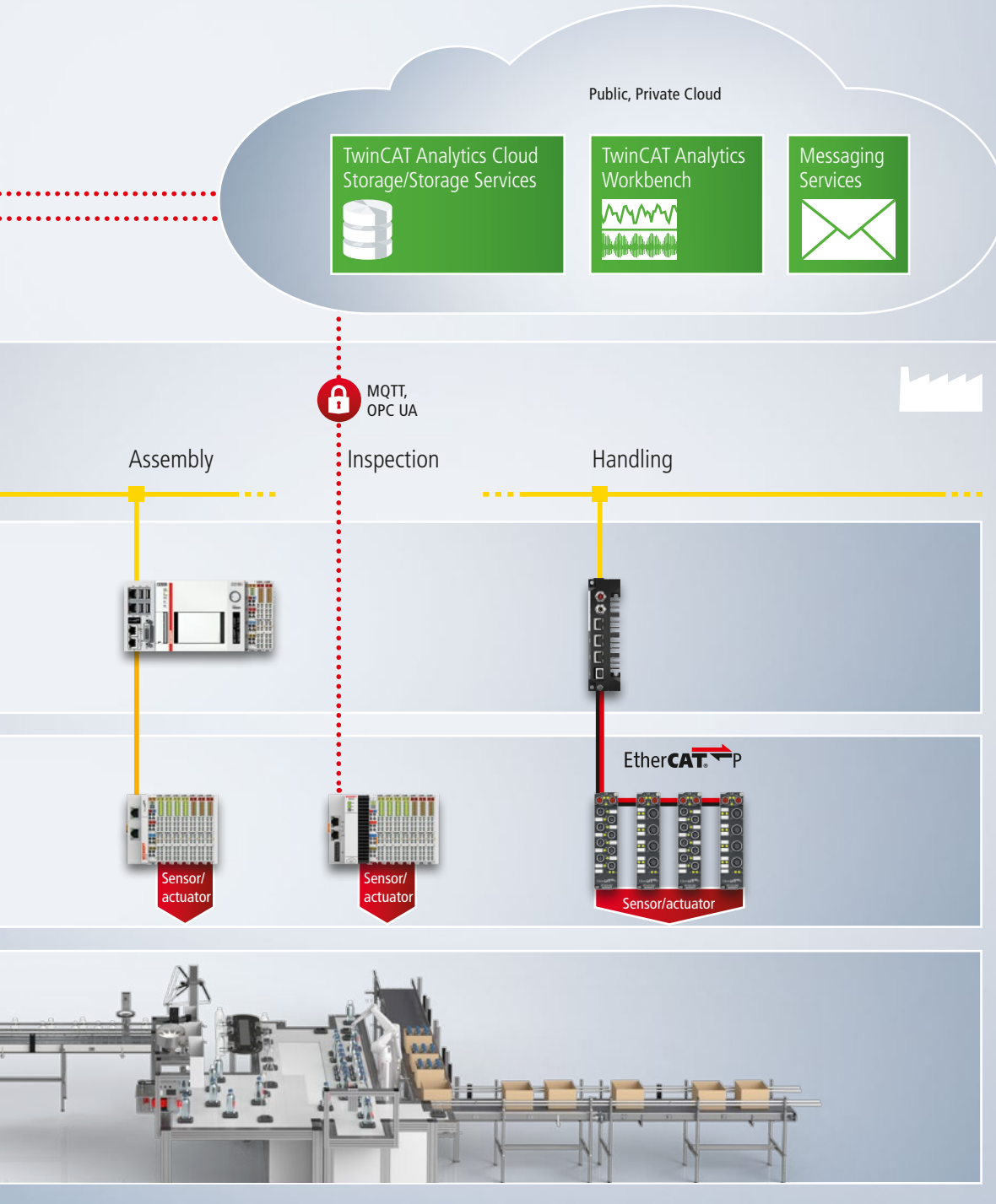
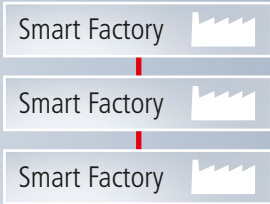

TwinCAT: One software platform for engineering and runtime

TwinCAT is the integrated platform for engineering, control, measurement, vision, diagnostics and analytical functions such as machine learning. Support for all common fieldbus systems and software protocols enables continuous communication from the IT system to the field level. Suitable programming languages are available for every task with IEC 61131-3, C/C++ and an open interface to MATLAB®/Simulink®. Numerous PLC libraries with function blocks according to the PLCopen Motion Control standard facilitate programming. Due to the multi- and many-core capability of TwinCAT 3, performance can be increased significantly,

so that extensive data analysis, image processing and robotic applications can be executed in the central control system without impacting performance.

Because it is a standardized software tool, TwinCAT reduces engineering time and costs. Robotic and motion control functions can be synchronized on one platform using TwinCAT NC PTP (point-to-point axis positioning) or NC I (axis interpolation in three dimensions). Using TwinCAT, almost all robot kinematics can be programmed in regular PLC programming languages, minimizing the effort and costs for programming a separate robot control. Integration of C and C++

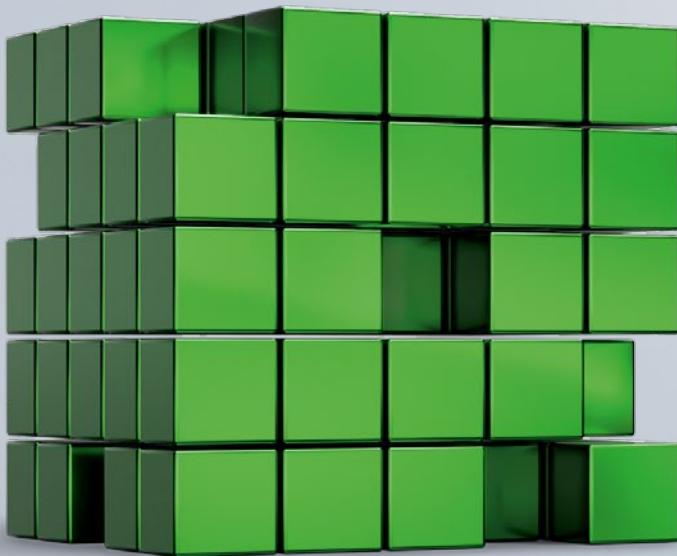

MATLAB®/Simulink®



TcCOM modules encapsulate customer IP



PLC



TwinCAT® 3

code also allows you to develop your own robot kinematics and integrate them with ease into the overall system. In addition, MATLAB®/Simulink® support facilitates the use of existing models, for example, for controllers.

The established TwinSAFE safety technology simplifies the implementation of functional safety in complex systems; variants can be replicated with ease in software. In this way, production cells can be developed and commissioned module by module, for example. The integrated web-based visualization solution, TwinCAT HMI, enables convenient development and maintenance of user interfaces. The information is presented either on

the machines and systems or in a web browser for access from anywhere.

TwinCAT Vision integrates image processing seamlessly with the control platform. Since this allows you to perform configuration and programming tasks in a familiar environment, it simplifies the engineering process considerably. At the same time, all control functions derived from image processing can be synchronized accurately in real time in the runtime system. Latencies are eliminated since all image processing algorithms are executed in real time.

TwinCAT IoT supports standard communication protocols for cloud applications and thus

allows data to be aggregated in the cloud or locally at production sites. The collected data can be analyzed specifically with the help of TwinCAT Analytics. TwinCAT Cloud Engineering allows the use of the familiar TwinCAT Engineering and Runtime products directly in the cloud. The TwinCAT interfaces to machine learning algorithms make it possible to use AI methods in the traditional controller environment.

► www.beckhoff.com/twincat

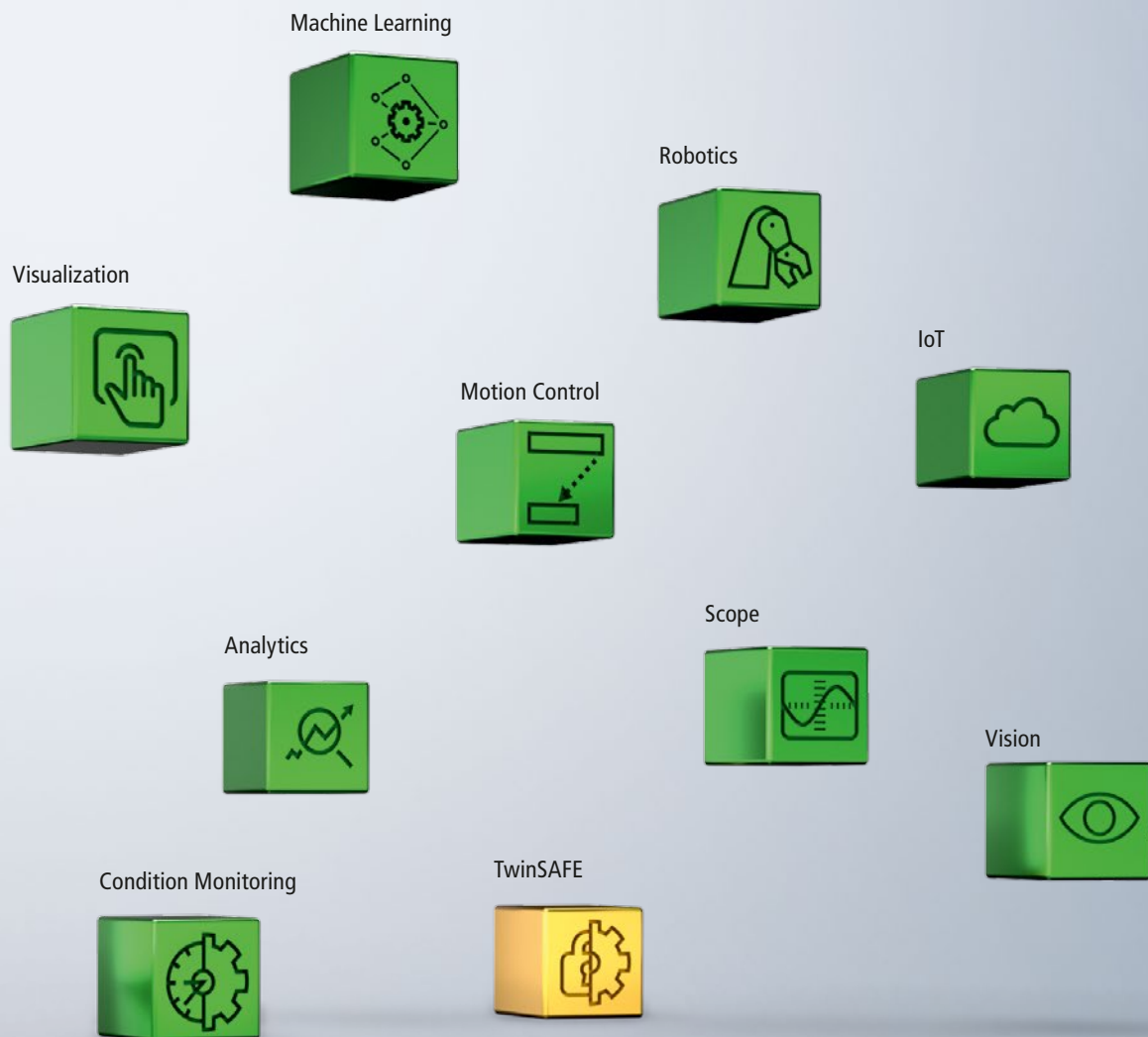

Optimized precision with TwinCAT Kinematic Transformation

TwinCAT Kinematic Transformation integrates the entire robot control functionality into the automation software so that PLC, motion control and robotics are executed on one Industrial PC. In addition to the cartesian gantry, serial and parallel 2D kinematics as well as 3D delta kinematics, 6-axis kinematics and others are also available. The required kinematics can be selected and parameterized conveniently in the TwinCAT Engineering (XAE). The kinematic channel is used to specify the type (e.g., delta or SCARA) and the respective features (bar lengths and offsets). Mass and mass inertia values can be specified for dynamic pre-control. In addition, tracking

functions can be implemented for which pre-assembled components are available. This means that the robot is synchronized with a moving object, so that it can pick up workpieces from conveyor belts or inclined turntables, for example.

Using TwinCAT Kinematic Transformation, various parallel and serial kinematics, such as those used for pick-and-place tasks, can be realized effortlessly. The seamless integration of the robot kinematics into the control system allows not only an additional robot CPU to be dispensed with, but also provides for optimum interaction and synchronization with the PLC. In conjunction with TwinCAT 3 Motion Pick-and-Place (TF5420),

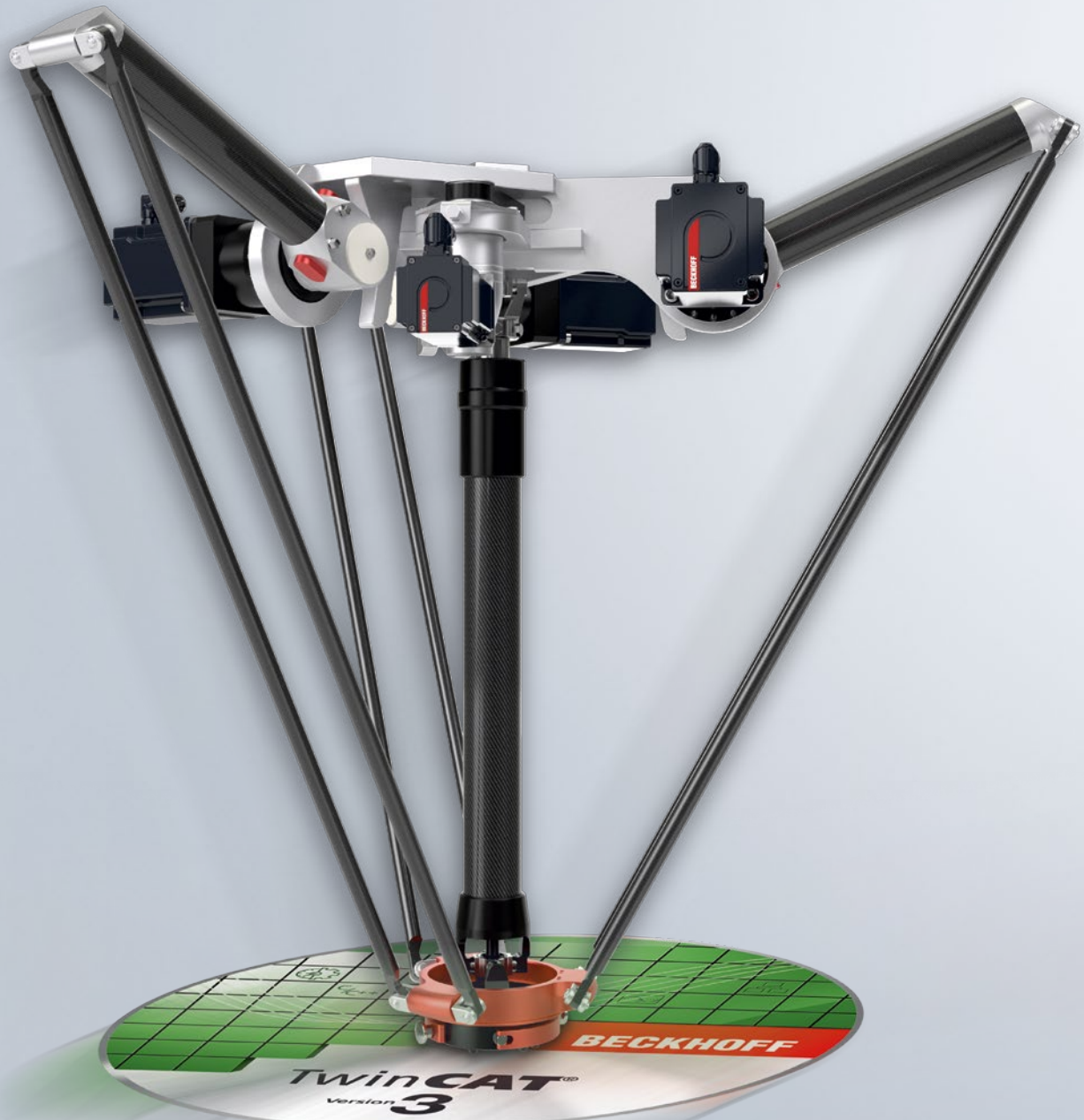











coordinated algorithms are used to achieve short cycles. Since everything runs on one controller, the communication overhead between separate systems is replaced by seamless interfaces. This results in high performance and improved accuracy.

The software functionality of TwinCAT, in conjunction with our powerful Industrial PCs and the drives with One Cable Technology (OCT), enables machine builders to implement their own robot solutions to meet specific market requirements and be well equipped for the future.

► www.beckhoff.com/twincat-kinematic-transformation

TwinCAT Kinematic Transformation requires TwinCAT NC I and is split into four levels:

<p>Level 4: includes level 3 as well as 5D and 6D kinematics in serial, parallel or hybrid design</p>	 <p>6D articulated robot</p>	 <p>6D Stewart platform</p>	 <p>5D kinematics</p>
<p>Level 3: includes level 2 as well as more complex kinematics such as 3D and 4D kinematics in serial, parallel or hybrid design</p>	 <p>serial 3D kinematics</p>	 <p>4D SCARA kinematics</p>	 <p>3D delta kinematics</p>
<p>Level 2: includes level 1 as well as additional, simpler kinematic transformations: 2D kinematics in serial parallel design</p>	 <p>2D shear kinematics</p>	 <p>2D roller kinematics (H-Bot)</p>	 <p>2D parallel kinematics</p>
<p>Level 1: static transformation (translation and rotation) and various compensations</p>	 <p>Cartesian portal</p>		

Flexible integration of robotics into TwinCAT

Controlling the robot kinematics

In combination with TwinCAT Kinematic Transformation (TF511x), various robot kinematics can be controlled from within TwinCAT. Path planning and kinematic transformations are executed directly in TwinCAT. A wide variety of kinematics already exists, with the possibility to also integrate customer-specific applications.

Pick-and-place movements can be programmed directly from the TwinCAT PLC with a choice of different libraries. Path planning is implemented, for example, with TwinCAT NC I according to DIN 66025, i.e., a description is provided of the contours traveled with the robot.

Controlling pick-and-place robots and XTS systems

One CPU for all control tasks: TwinCAT can control the XTS and, for example, a delta robot at the same time. You therefore only need one programming environment to control the entire system. Eliminating the need for complex communication between different controllers also optimizes cycle times.

EAP (EtherCAT Automation Protocol)

Direct control of robot kinematics



Industrial PC
(EtherCAT master)



- TwinCAT 3 PLC/NC I
- TwinCAT 3 Kinematic Transformation

EtherCAT

Power supply modules AMP8620

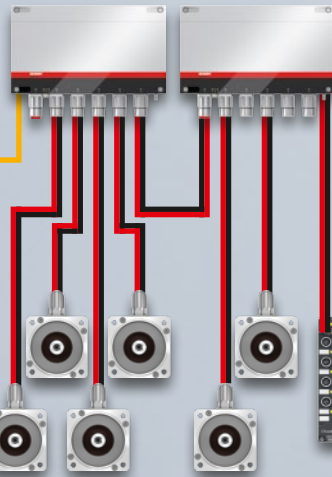

Distributed servo drives AMP8000

EtherCAT P

EtherCAT P Box modules

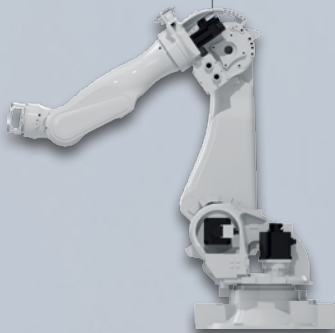

6-axis articulated robot

Direct control of pick-and-place robots and XTS



Industrial PC
(EtherCAT master)



- TwinCAT 3 PLC/NC I
- TwinCAT 3 Kinematic Transformation
- TwinCAT 3 XTS Extension

EtherCAT



EtherCAT Terminals



EtherCAT AMI auxiliary axes

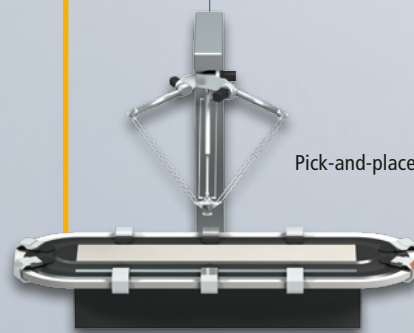

Pick-and-place robot

Linear transport system XTS

Integrating an external robot controller in TwinCAT

The TwinCAT TF5120 and TF5130 functions extend the standard TwinCAT PLC (TC1200) and act as the basis for controlling articulated arm or SCARA robots. The motion commands for the robot are sent from the PLC to the robot controller. Support of the defined interfaces for KUKA robots (TF5120 mxAutomation) and Stäubli robots (TF5130 uniVAL PLC) allow robot movements to be commanded directly from TwinCAT. The advantage for you: Because the motion profiles of the robot application are programmed with TwinCAT PLC function blocks, there is no need for complex or specific robot programming.

Controller communication based on the EtherCAT Automation Protocol (EAP)

The EtherCAT Automation Protocol (EAP) allows extremely efficient handling of horizontal communication between robots and machines or integration with a central host computer. EAP enables real-time communication in the millisecond range. The protocol is based on a classic Ethernet infrastructure and can be transmitted via any Ethernet media – also wirelessly.

- ▶ www.beckhoff.com/ethercat
- ▶ www.beckhoff.com/twincat3

Integration of an external robot controller in TwinCAT

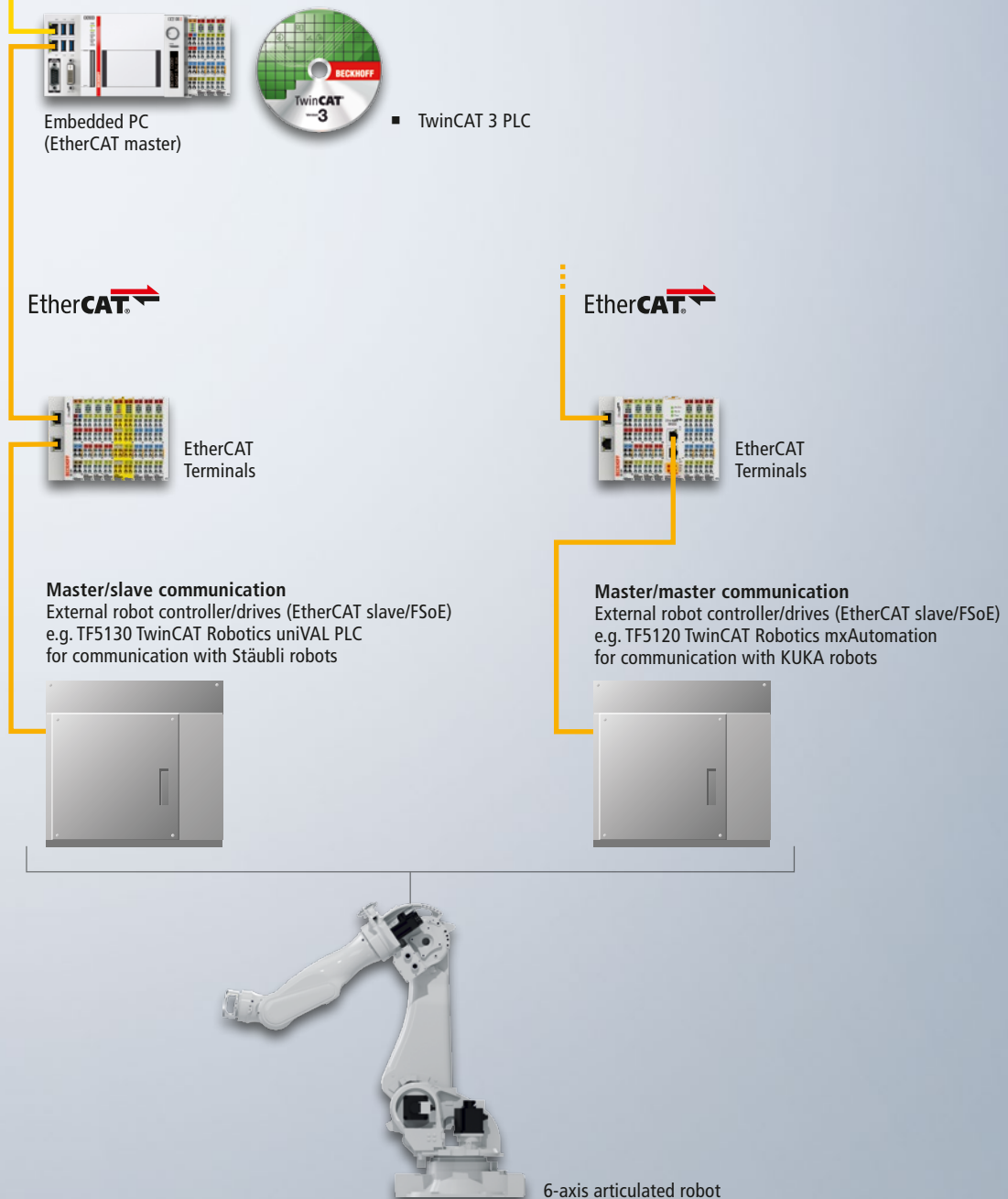

Scalable drive technology for highly dynamic motion tasks

Our scalable drive solutions cover a broad range of applications: from DC or stepper motors to compact servomotor terminals through to the high-performance servo amplifiers in the AX series. Precisely scalable in terms of design and performance, they facilitate the implementation of optimized drive concepts for rotary applications.

The XTS linear transport system and XPlanar eXtended planar motor system set new standards in drive technology and open the door to completely new application scenarios. The outstanding performance of EtherCAT ideally supports integration with PC-based control technology as well as

connection to other communication systems. Kinematics and positioning tasks can be implemented with TwinCAT Motion function blocks.

Robotic applications and handling machines involve positioning and moving a variety of axes individually or in correlation with one another in a highly dynamic way. The integrated, fast control technology of the AX8000 multi-axis servo system is ideal for this purpose. The flexible concept with 1- or 2-channel axis modules and the variable distribution of the motor output offer a cost-optimized solution for a wide range of drive technology applications. Leveraging the One Cable Technology of the AM8000 servomotor series,



Servomotor terminal
ELM7211

Distributed servo drives
AMI8000

Multi-axis servo system
AX8000

where the power and sensor cables are combined in a single standard motor cable, wiring overhead and commissioning costs can be reduced.

With optionally integrated safety technology, our drive portfolio fulfills strict requirements concerning machine safety and simplifies the control configuration in the different applications.

► www.beckhoff.com/motion



Synchronous servomotors
AM8000

XTS
XPlanar

Distributed servo drive system and EtherCAT P for a control cabinet-free production

One Cable Technology (OCT) is a standard shaped by Beckhoff for years, which reduces material and commissioning costs by 50% and is used for connecting motors. The consistent further development of EtherCAT and the OCT concept is EtherCAT P, the One Cable Technology for the I/O devices at field level. EtherCAT P combines EtherCAT communication with power supply for the connected users in a single 4-wire standard Ethernet cable. All advantages of EtherCAT, especially the free choice of topology, are maintained. Using hybrid cables, One Cable Automation simplifies system wiring in machine design since

the components, terminal boxes and machine modules only need to be connected using a single cable.

The AMP8000 distributed servo drive system breaks new ground in modular machine design. It integrates the servo drive directly into the servomotor, resulting in a highly compact form factor. By relocating the power electronics directly to the machine, only a single coupling module needs to be housed in the control cabinet. This module can control up to five distributed AMP8000 servo drives via the AMP8805 distribution module, which is likewise connected via EtherCAT P.

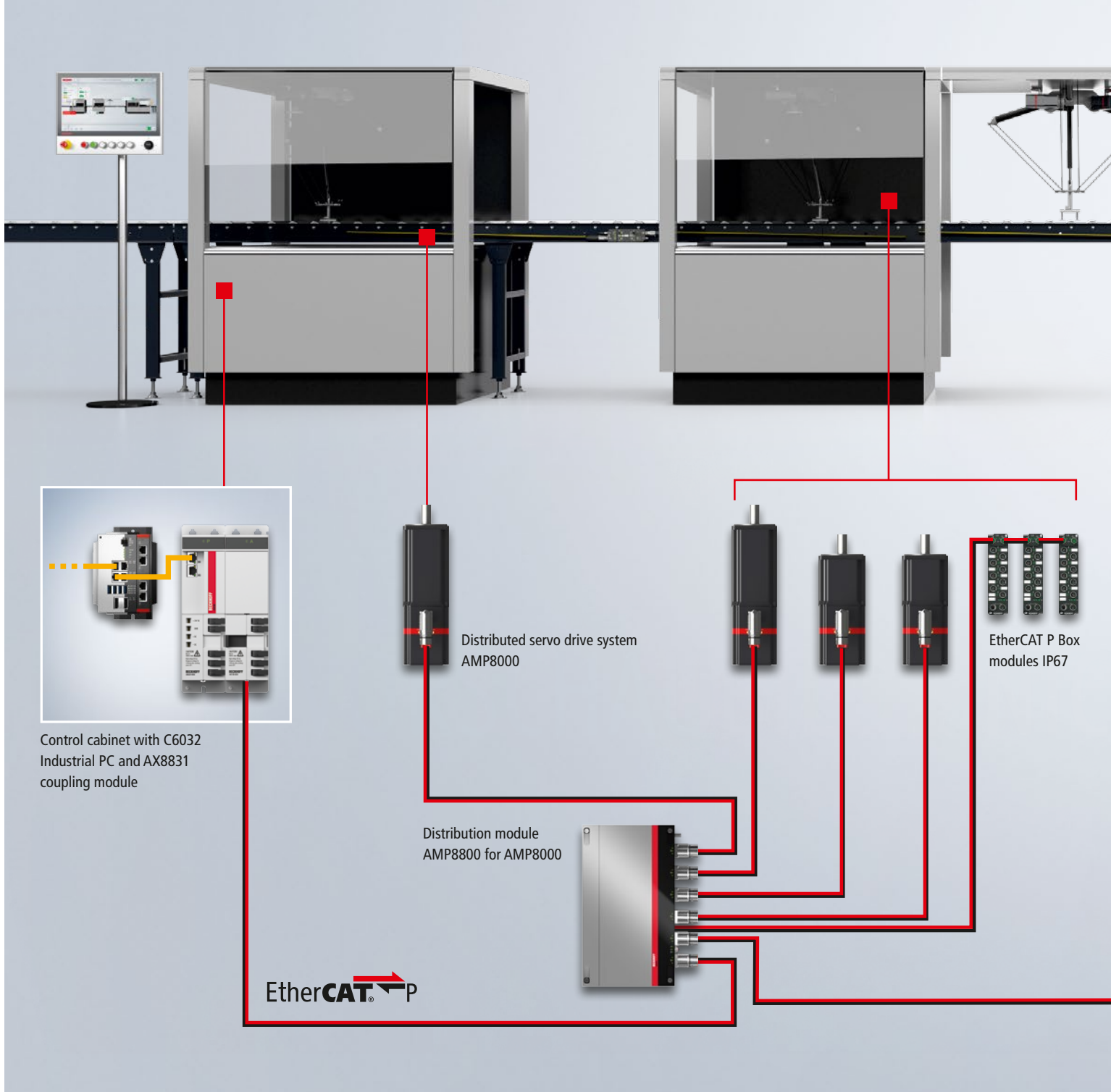

And since the entire system is cascable, even complex systems can be implemented with a simple topology.

Further advantages – in addition to the savings mentioned – are the reduction of error sources during planning and installation as well as an increased availability due to system-related diagnostics.

A further expansion stage on the path to control cabinet-free machines is achieved through use of the AMP8620 supply module. The connection to the control cabinet can be eliminated fully in this case. The EP7402 EtherCAT Box offers two

outputs with an integrated controller for the direct connection of 24 V DC conveyor roller motors or other BLDC motors, and takes over the complete control of the connected devices independently of the manufacturer of conveyor or motor.

- ▶ www.beckhoff.com/ethercat-p
- ▶ www.beckhoff.com/distributed-servo-drive-system

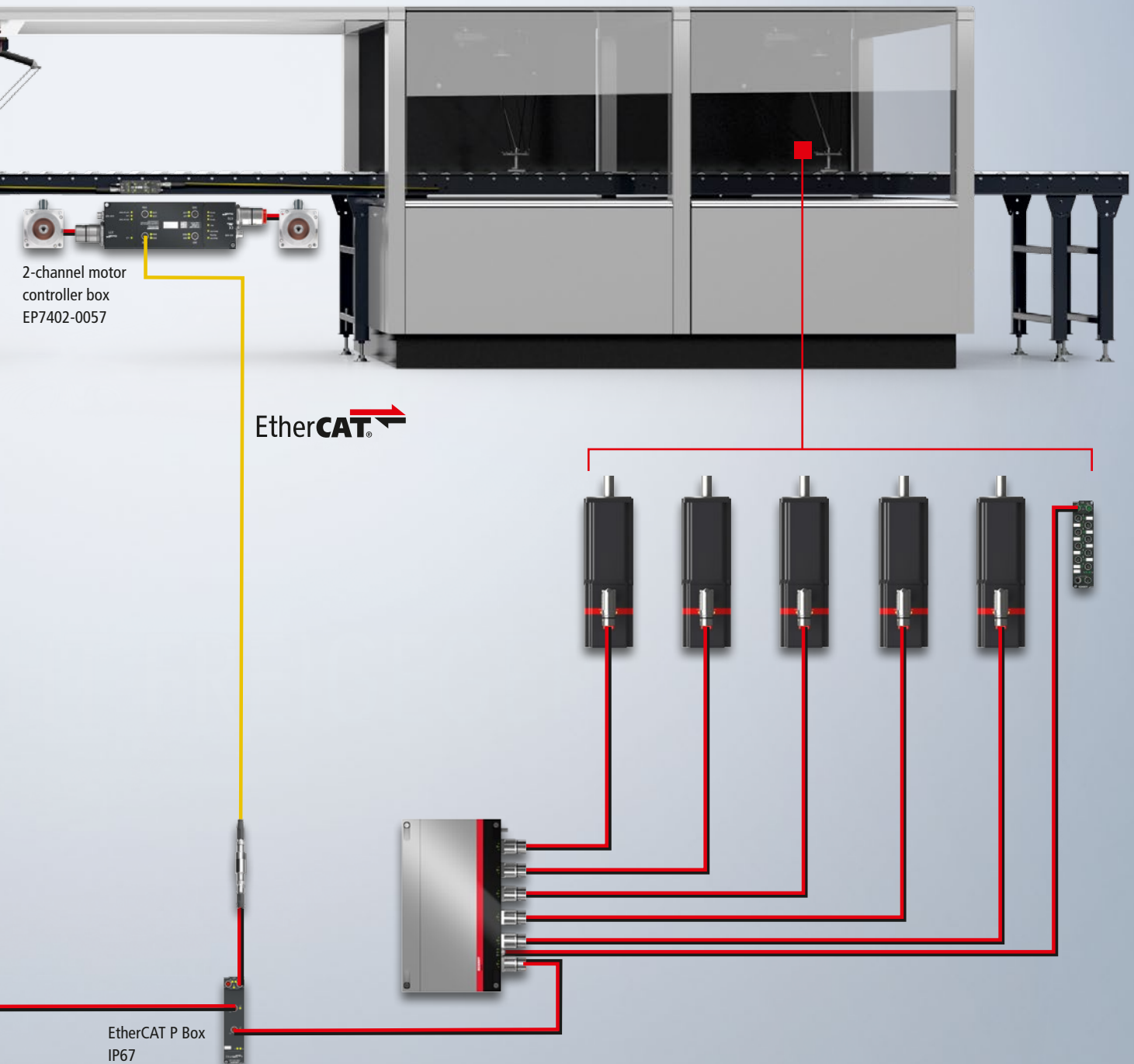

Efficient
and flexible:
PC-based control
for handling and
assembly

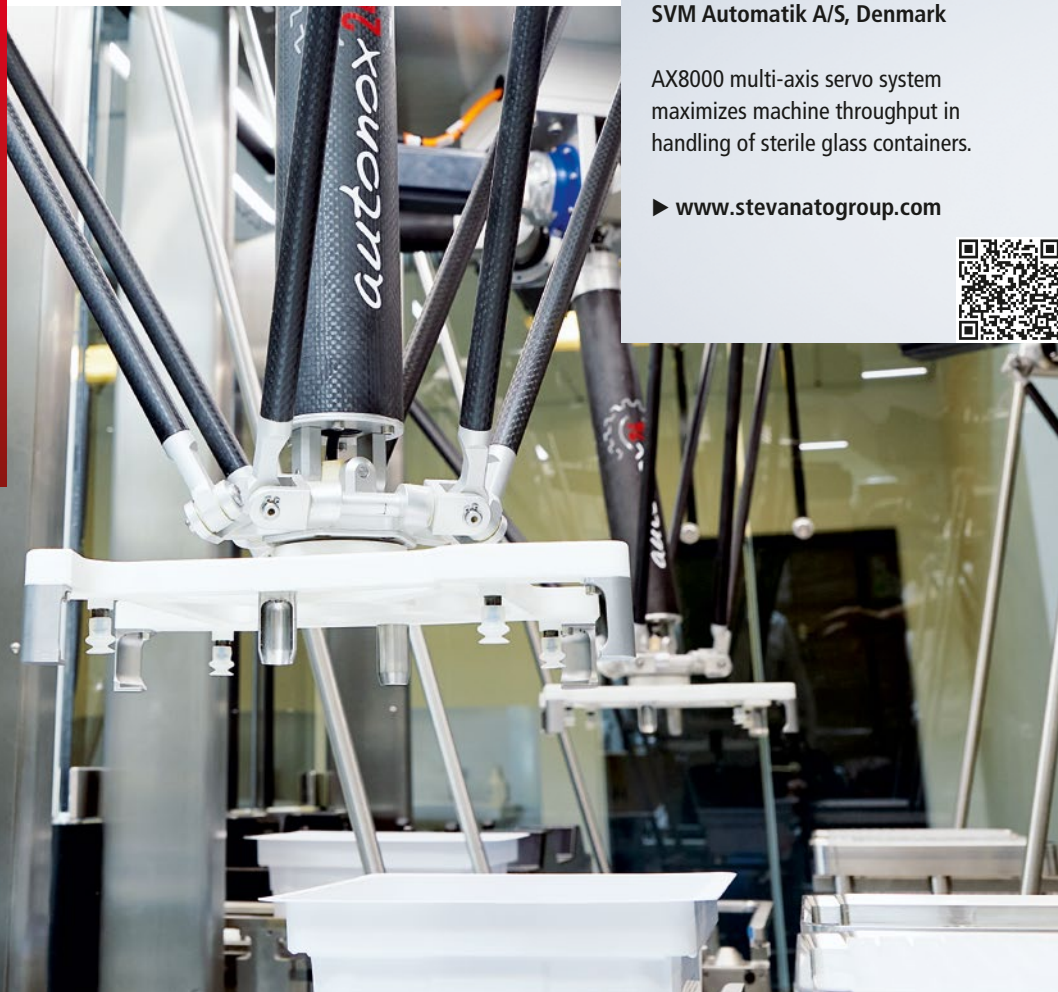

SVM Automatik A/S, Denmark

AX8000 multi-axis servo system
maximizes machine throughput in
handling of sterile glass containers.

► www.stevanatogroup.com



© Beckhoff



Keller AG, Switzerland

Open and scalable control
technology reliably automates
process sequences.

► www.keller-druck.com



© Keller AG

TEUP, Austria

Individually configurable
assembly line with oval XTS for
maximum machine flexibility

► <https://teup.at>

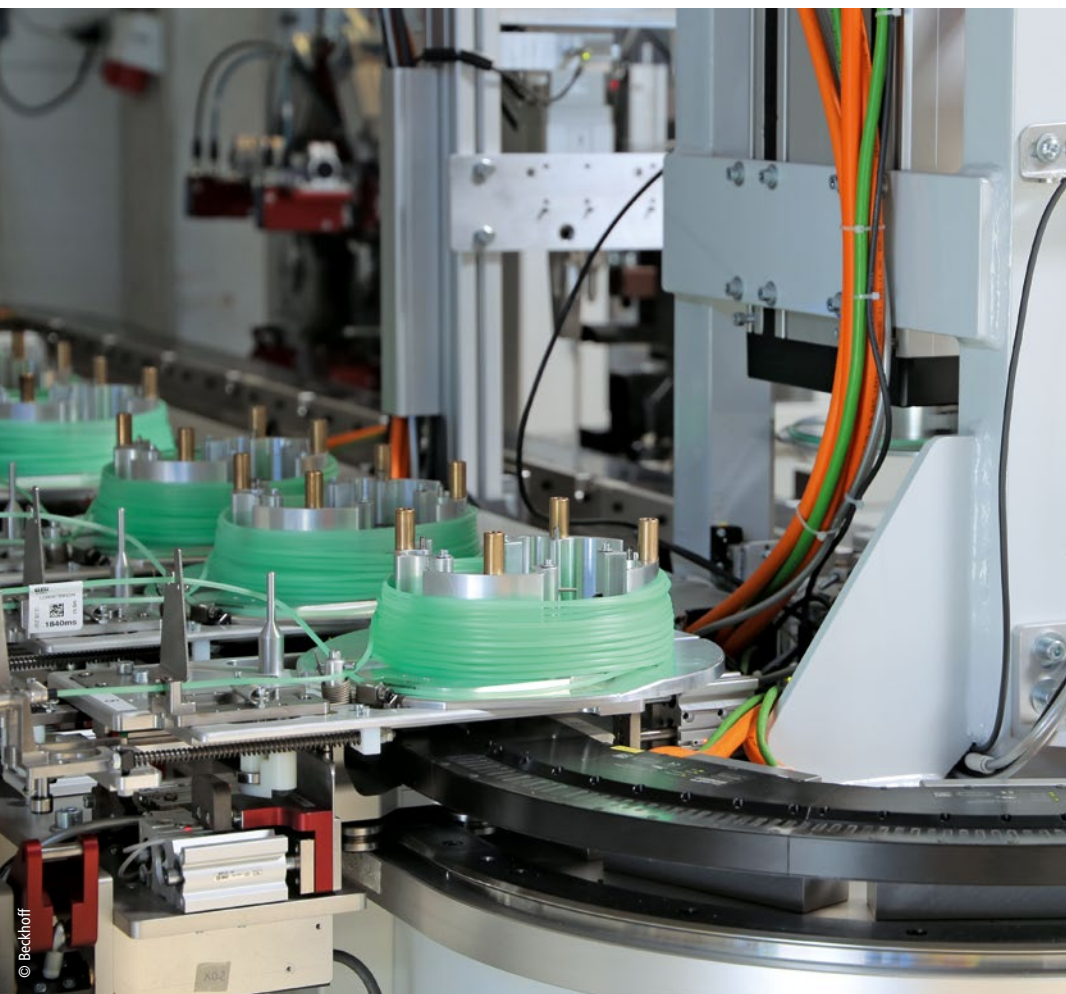

© Beckhoff

GROB-WERKE, Germany

Flexible control technology
optimizes hairpin stator
production lines.

► www.grobgroup.com

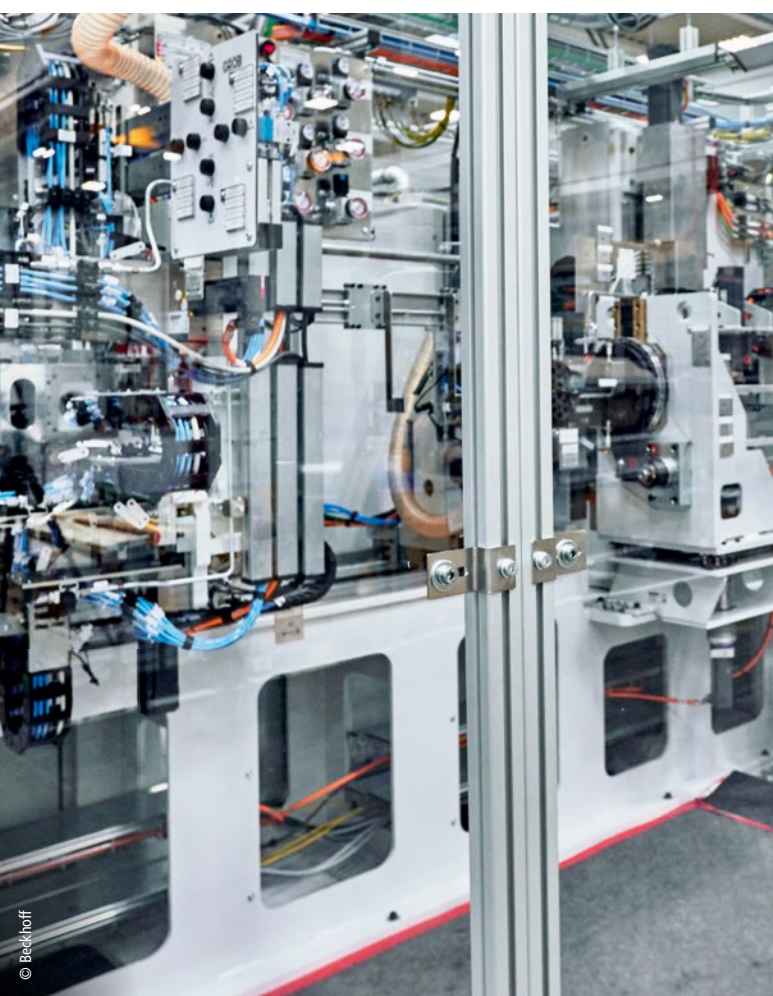

© Beckhoff



Which application in assembly and handling technology
would you like to optimize with PC-based control?

Get in touch with us at:

► www.beckhoff.com/robotics

Beckhoff Automation GmbH & Co. KG

Hülshorstweg 20

33415 Verl

Germany

Phone: +49 52469630

info@beckhoff.com

www.beckhoff.com

Beckhoff®, TwinCAT®, TwinCAT/BSD®, TC/BSD®, EtherCAT®, EtherCAT G®, EtherCAT G10®, EtherCAT P®, Safety over EtherCAT®, TwinSAFE®, XFC®, XTS® and XPlanar® are registered trademarks of and licensed by Beckhoff Automation GmbH. Other designations used in this publication may be trademarks whose use by third parties for their own purposes could violate the rights of the owners.

© Beckhoff Automation GmbH & Co. KG 06/2022

The information provided in this brochure contains merely general descriptions or characteristics of performance which in case of actual application do not always apply as described or which may change as a result of further development of the products. An obligation to provide the respective characteristics shall only exist if expressly agreed in the terms of contract.

We reserve the right to make technical changes.