

**BECKHOFF** New Automation Technology

Compact drive technology:  
System-integrated and powerful



# Integrates all drive technologies: PC-based control

With its highly scalable drive technology portfolio, Beckhoff offers the right motion solution for all automation tasks – including in the low voltage range up to 48 V, in which the technology leader for PC and EtherCAT-based control systems offers a broad range of compact drive solutions (for integration at I/O level). All common forms of drive technology are supported: in addition to servomotor and stepper motor controllers, BLDC, DC, and PWM output stages can be integrated directly. All of these products are available both as IP20 variants in the familiar terminal format and as IP67 box modules for use outside the control cabinet.

The power spectrum extends from 50 mA for controlling external power amplifiers through to 16 A for direct operation of a servomotor. Direct integration in Beckhoff's TwinCAT automation software simplifies and accelerates commissioning. This means that all drive technologies for compact drives forms an integral part of Beckhoff's I/O system. An extensive range of accessories, including pre-assembled connector cables and gear units, as well as brake chopper terminals, braking resistors, or an external fan cartridge are also available for increasing performance.

## The most important advantages at a glance:

- direct integration of all motion components in the I/O system
- highly scalable portfolio of compact drive technology: different designs and performance classes to meet your specific requirements, technologies, and applications
- IP20 for solutions in the control cabinet or terminal boxes
- IP65/67 for applications without control cabinets



**Servomotor terminals**  
Fully functional servo amplifier in EL or ELM EtherCAT Terminal format for 48 V DC. Power spectrum from 200 watts to almost 1 kW output power.

**Stepper motor terminals**  
Control of stepper motors for the safety extra-low voltage range.

**BLDC motor terminals**  
Control of BLDC motors up to 48 V DC, with hardware-enable-input for STO applications.

**DC motor terminals**  
Operation of DC motors for 24/48 V DC

**PWM output terminals**  
PWM output terminals for operating valves/stepper motor output stages or for encoder simulation.



# The high-performance servo drives: ELM72xx and AMI812x

With its high-performance servomotor terminals in the ELM72xx series and the integrated AMI812x servo drives, Beckhoff offers innovative and highly compact servo solutions in the servo drive technology sector. The new ELM72xx EtherCAT Terminals are fully functional servo drives in a robust metal housing that deliver an output current of up to 16 A at 48 V DC for the supply voltage. The ELM72xx series enables direct connection of motor, feedback, and brake via the convenient connector front end and offers an integrated absolute value interface. The power and feedback systems are combined in the standard motor cable based on One Cable Technology (OCT). The programmable TwinSAFE

Logic for directly implementing the safety application in the terminal is also integrated. The metal housing can be connected directly to the Beckhoff EtherCAT Terminals and offers optimum heat dissipation even at high output power, as well as optimal shielding against electrical interference. With the AMI812x servo drive, Beckhoff is extending its compact drive technology (up to 48 V DC) by devices that can be installed decentrally in the field. This means that the servo motor, output stage, and fieldbus connection are available in a space-saving design for automation in a performance range which extends to 400 watts. As an EtherCAT slave, the AMI812x can be placed directly on the machine

without upstream I/O level. Especially compact machines with a reduced footprint can thus be implemented in the control cabinet.

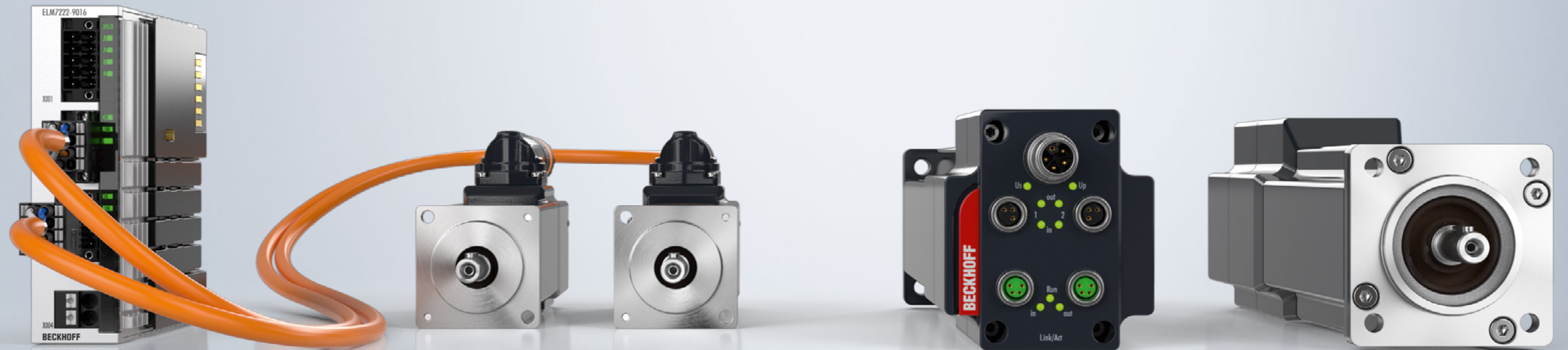



# Highly scalable: Beckhoff servo technology

Beckhoff's servo technology portfolio includes compact, fully functional servo amplifiers for direct control of servo motors. Thanks to the high scalability in all performance classes from 2.8 A to 16 A, virtually all applications in protection classes IP20 and IP67 can be covered. The compact servo technology is also available as a motor-integrated variant with the AMI812x. Integrated travel path control and direct integration of motor, feedback, and brake are assured, as are the safe motion functions in the ELM series, which is also available as a 2-channel output stage.

In contrast to the standard ELM72xx-0010 variants, which do not have safety functions, the ELM72xx-9016 (STO) and -9018 (Safe Motion) variants offer comprehensive safety functions.



ELM7201-0010,  
ELM7201-9014

AM8111: I = 2.8 Arms

2.8 A



ELM7211-9016,  
ELM7212-9018

EL7211-0010,  
EL7211-9014

EP7211-0034

EJ7211-0010,  
EJ7211-9414

AMI8121: I = 4.5 Arms

AM8121: I = 4.5 Arms

4.5 A



ELM7221-9016,  
ELM7222-9018

EL7221-9014

AMI8122: I = 8 Arms

AM8122: I = 8 Arms

8 A



ELM7231-9018,  
ELM7231-9016

AMI8123: I = 15 Arms

AM8141: I = 16 Arms

16 A



## More power, more features: The ELM series

Direct integration of the servo motor including feedback and brake via OCT (One Cable Technology): with its extremely compact design, the ELM series is one of the smallest servo drives on the market.



# Comprehensive: The portfolio for stepper motors

Output stages in different protection classes are available for stepper motors: the housing of the EtherCAT EL Terminals in IP20, the EtherCAT plug-in modules in IP20, and the EtherCAT box modules in IP67. The portfolio also covers two performance classes: the EL703x (EL7037, EL7031) for motors up to 1.5 A (in combination with the ZB8610 fan cartridge up to 3 A) as well as the EL704x (EL7047, EL7041) for motors up to 5 A (combined with the ZB8610 fan cartridge up to 6.5 A). Beckhoff stepper motor terminals are intended for direct integration of motors in the mid-performance class. Additional inputs support drive-related functions such as reference runs and end position monitoring.



EL7037,  
EL7031, EL7062



EP7041-1002



EJ7031

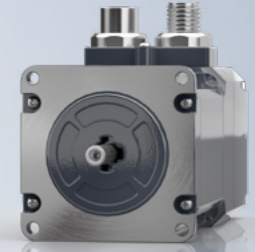

AS2021: I up to 3 A

3 A



EL7041-1000,  
EL7047, EL7041



EP7041-3002,  
EP7041-2002



EJ7047,  
EJ7041-0052



AS2042: I up to 6.5 A

6.5 A

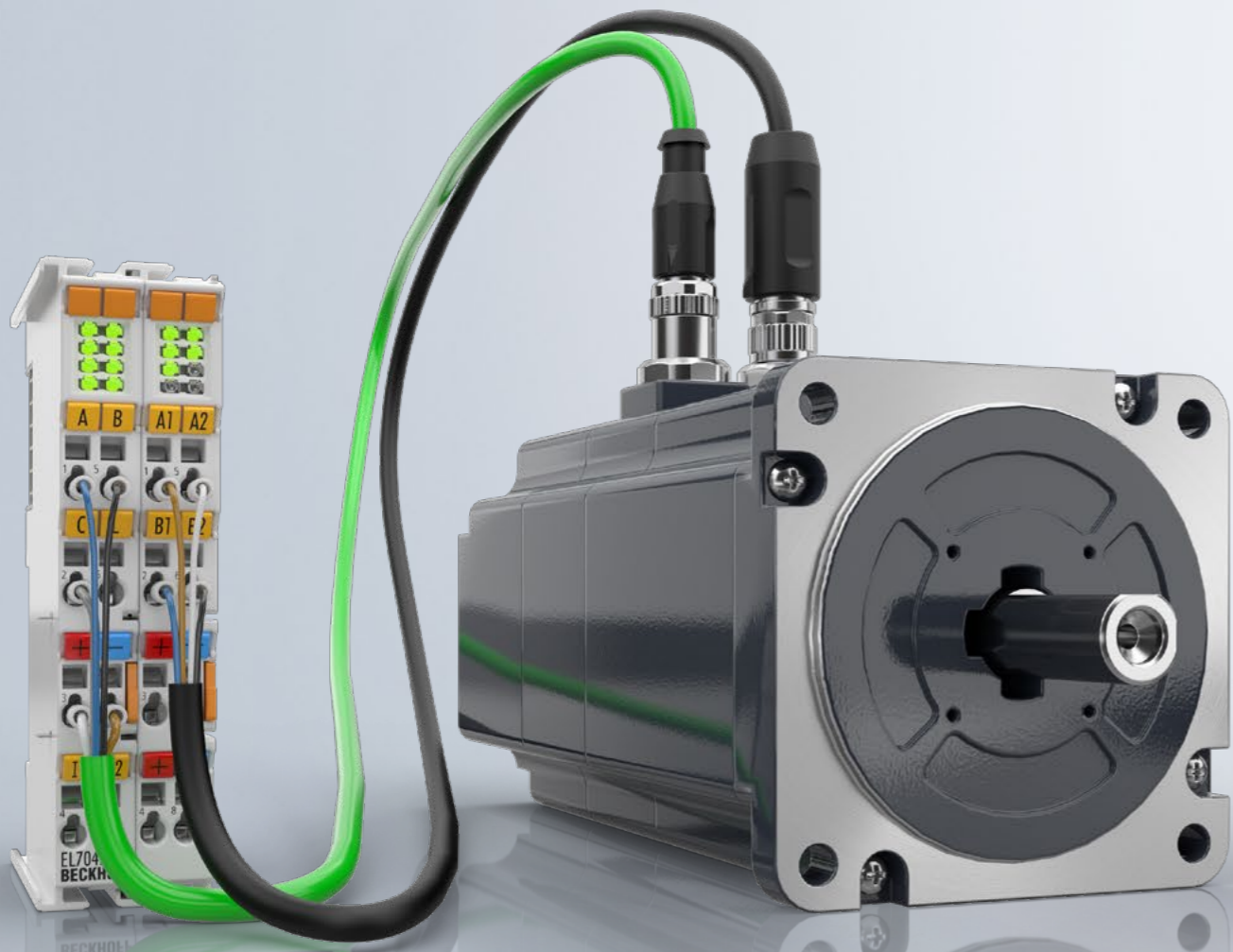

**Compact, high-performance stepper motor terminals**  
Motors with an output of up to 6.5 A at a 48 V DC supply voltage can be operated directly with Beckhoff's stepper motor solutions.

# Compact drive technology completed: With BLDC, DC, and PWM

Beckhoff's compact drive technology not only includes servo and stepper motor solutions, but also familiar drive technologies such as Brushless DC (BLDC), DC, and PWM. All are available as system-integrated solutions and thus complete the PC and EtherCAT-based control architecture. The BLDC technology allows integration of servomotors with encoder feedback or Hall effect sensors for direct connection to the terminal. In conjunction with the ZB8610 fan cartridge, DC motors with power output of up to 6.5 A can be operated directly on the terminals.

PWM controllers are available for different applications and performance classes. This means,

for example, that distributed output stages, which are controlled with pulse direction signal, can be connected directly to the pulse train terminals.

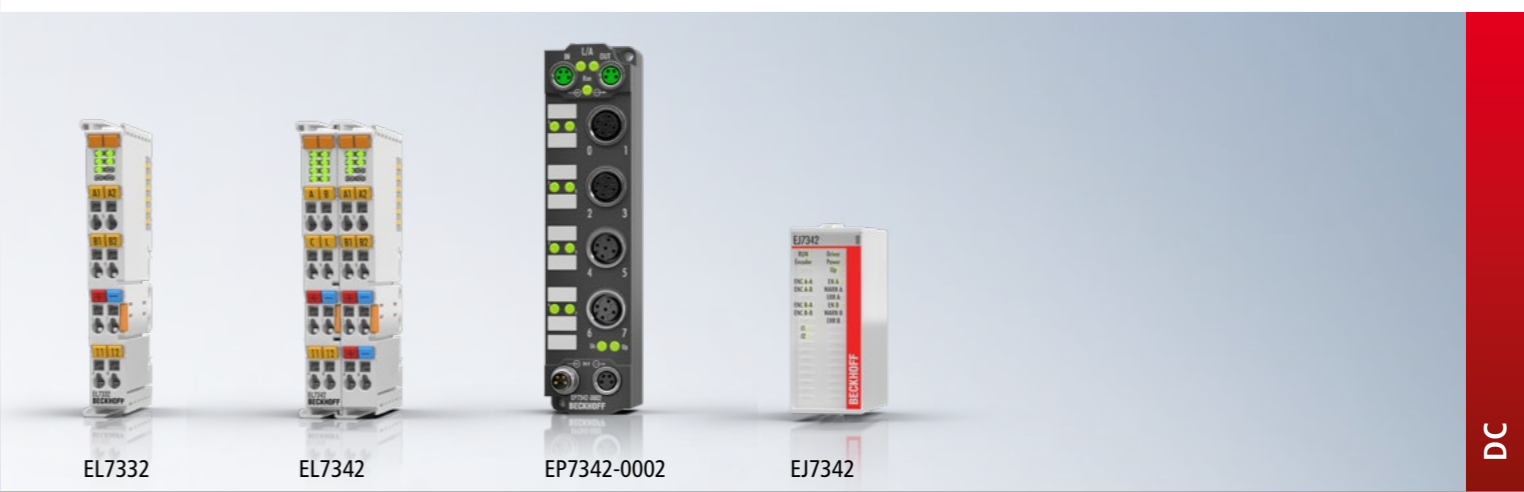

EL7332      EL7342      EP7342-0002      EJ7342



EL7411      EJ7411      EP7402-0057, EP7402-0167



EL2521, EL2522      EL2502      EL2535, EL2535-0005, EL2535-0103      EJ2502      EJ2521-0224

**Brushless DC solutions for connecting BLDC motors in IP67**  
The IP67 solution EP7402 offers two outputs with an integrated controller for direct connection of 24 V DC roller motors. Eight additional digital inputs/outputs enable connection, for example, of photoelectric barriers and communication between the box modules in operation without PLC.

DC

BLDC

PWM



# In-depth know-how and a broad portfolio: I/O & motion accessories

In addition to an extensive portfolio of I/O components and motors, Beckhoff offers a diverse range of accessories for commissioning compact drive technology. The original accessories ensure fast and reliable installation and increase the operational security of the entire system.

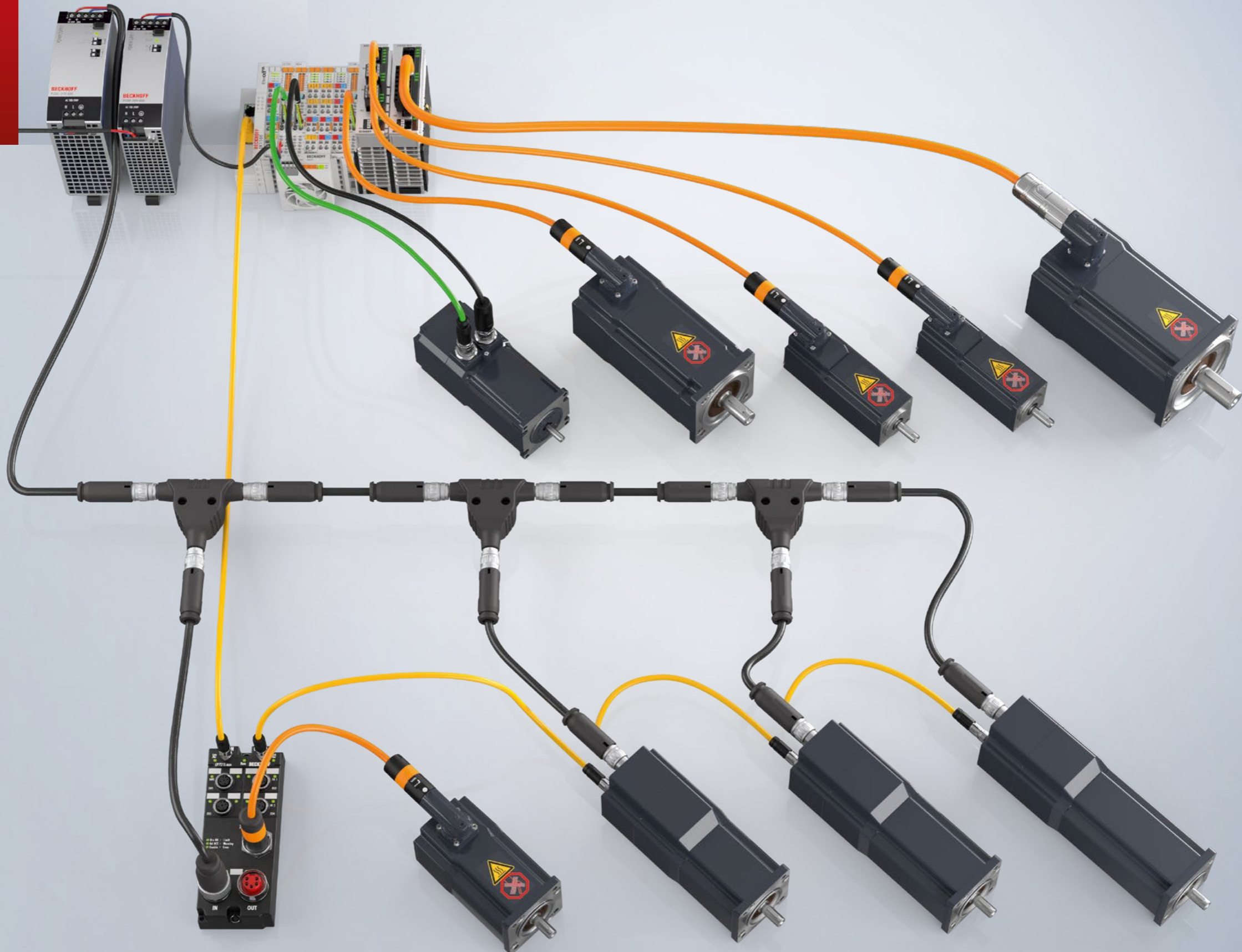



# In-depth know-how and a broad portfolio: I/O & motion accessories

In addition to cables sold by the meter, plug connectors, and a virtually seamless portfolio of pre-assembled cables, the extensive range of accessories also includes an external fan cartridge for improving performance, braking resistors, and DIN rail supply voltage units. The cables are available with protection ratings of IP20 or IP65/67 and are suitable for use in a wide variety of environmental conditions. Beckhoff offers cables for drag chain applications as well as torsion-resistant cables for robot applications and much more, all for use with high dynamic loads.

## Motor cables

Cable ZK4704-04x1-2zzz for OCT  
x = 0 fixed installation  
x = 2 drag-chain suitable  
x = 6 capable of torsion

► [www.beckhoff.com/zk4704-0401-2xxx](http://www.beckhoff.com/zk4704-0401-2xxx)



Cable ZK4701-04x1-2zzz for OCT  
x = 0 fixed installation  
x = 2 drag-chain suitable  
x = 6 capable of torsion

► [www.beckhoff.com/zk4701-0401-2xxx](http://www.beckhoff.com/zk4701-0401-2xxx)



Cable ZK4000-6700-2zzz for motor cable AS1000, drag-chain suitable

► [www.beckhoff.com/zk4000-6700-2xxx](http://www.beckhoff.com/zk4000-6700-2xxx)



Cable ZK4000-6768-0zzz for motor cable AS1000, drag-chain suitable

► [www.beckhoff.com/zk4000-6768-0xxx](http://www.beckhoff.com/zk4000-6768-0xxx)



Cable ZK4000-7700-2zzz for motor cable AS2000, drag-chain suitable

► [www.beckhoff.com/zk4000-7700-0xxx](http://www.beckhoff.com/zk4000-7700-0xxx)



Cable ZK4000-6877-0zzz for motor cable AS2000, drag-chain suitable

► [www.beckhoff.com/zk4000-6877-0xxx](http://www.beckhoff.com/zk4000-6877-0xxx)



Cable ZK4000-5100-2zzz for resolver, drag-chain suitable

► [www.beckhoff.com/zk4000-5100-2xxx](http://www.beckhoff.com/zk4000-5100-2xxx)



Cable ZK4000-5151-0zzz for resolver, drag-chain suitable

► [www.beckhoff.com/zk4000-5151-0xxx](http://www.beckhoff.com/zk4000-5151-0xxx)



### Input

Cable ZK205x-5y00-0zzz for power supply  
x = 0 cable structure 5 x 1.5 mm<sup>2</sup> ;  
x = 1 cable structure 5 x 2.5 mm<sup>2</sup> ;  
x = 3 cable structure 5 x 0.75 mm<sup>2</sup>

► [www.beckhoff.com/zk2050-5200-0xxx](http://www.beckhoff.com/zk2050-5200-0xxx)



### Input/Output

Cable ZK2000-2122-xzzz for sensor/actuator  
x = 0 drag-chain suitable  
x = 3 fixed installation  
x = 6 capable of torsion

► [www.beckhoff.com/ZK2000-2122-0xxx](http://www.beckhoff.com/ZK2000-2122-0xxx)



Cable ZK1090-3191-xzzz  
EtherCAT connection cable  
x = 0 drag-chain suitable  
x = 3 fixed installation  
x = 6 capable of torsion

► [www.beckhoff.com/zk1090-3191-0xxx](http://www.beckhoff.com/zk1090-3191-0xxx)



Cable ZK1090-3131-xzzz,  
EtherCAT connection cable  
x = 0 drag-chain suitable  
x = 3 fixed installation  
x = 6 capable of torsion

► [www.beckhoff.com/zk1090-3131-0xxx](http://www.beckhoff.com/zk1090-3131-0xxx)



► [www.beckhoff.com/io-accessories](http://www.beckhoff.com/io-accessories)

## Expansion of the performance range



### ZB8610 | Fan cartridge

Fan cartridge for forced air circulation: the improved heat dissipation, for example, allows operation of I/O components in compact drive technology with higher output currents



### ZB81xx | External braking resistor

The external braking resistors are directly connected to the terminal to regulate intermediate circuit voltages for harder braking. Here, the ZB8110, with 10 Ω resistance, is the perfect accessory for the EL9576 brake chopper terminal, and the ZB8103 at 3 Ω can also be directly connected to the ELM72xx servomotor EtherCAT Terminal angeschlossen werden. The relevant I2t model for resistance is automatically evaluated in the terminal.

### EL9576 | Brake chopper terminal

Brake chopper terminal with integrated high-performance capacitors for stabilizing supply voltages. If the regenerative energy exceeds the capacity of the capacitors, energy can be dissipated via an external braking resistor. The switching threshold of the terminal can be parameterized directly. The terminal has extensive diagnostic information, which is directly available to the user through the process data.

## Power supply units

The Beckhoff power supply units win over customers with high efficiency levels of up to 96.3%. Low heat loss preserves all the components in the control cabinet and reduces energy costs. The higher the efficiency, the smaller the devices become. Beckhoff offers a portfolio of power supply units which all save space with their compact housing. In addition to this, power supply units bring together high-performance mains units and the ultra-fast EtherCAT communication standard, using EtherCAT. Integrating EtherCAT technology enables the controller to process extensive measurement and internal device data directly for reliable and consistent system monitoring.

### Power supply units in the PS series for every application

- long service life and high reliability, thanks to low heat loss
- high efficiency of up to 96.3% thanks to optimized convection cooling
- ideal for motion applications thanks to high back EMF
- 1- and 3-phase DIN rail power supplies for output voltages of up to 24/48 V DC
- start up demanding loads with short-term overload capacity of 150%
- expanded functions thanks to buffer and redundancy modules
- additional device series with EtherCAT interfaces





# Beckhoff: The Motion Company

As a central component of your automation solution, Beckhoff drive technology not only offers drive controllers and motors for all application areas and performance classes, but also the right industrial PC and a diverse array of panel solutions for visualizing your processes. With its extensive and high-performance tools such as Motion Designer, Drive Manager 2, or TwinCAT 3 Scope, TwinCAT 3 offers you an optimum development environment for implementing the requirements for drive technology quickly and efficiently.

## TwinCAT 3 Motion Designer

Designing and commissioning drives is straightforward and user friendly with the aid of the customary TwinCAT 3 software tools. This simplifies application calculations and the dimensioning of the drive components (motor, servo drive, and other accessories) when designing the drive system using the engineering component TwinCAT 3 Motion Designer. Designers can access the technical data sheet for the motor and gear units with a simple click and the associated 3D model of the drive components for integration in their design software with another click.

## TwinCAT 3 Drive Manager 2

The proven TwinCAT 3 Drive Manager 2 engineering tool guides the user through commissioning step-by-step. Drive parameters can also be displayed, adjusted, and the impact on the drive response can be examined, even during operation, for optimization purposes. Drive Manager 2 supports the commissioning of the AX8000 multi-axis servo system, the AX5000 digital compact servo drive, the AMP8000 distributed servo drive system, the AMI8100 integrated servo drives, or the I/O components EL72xx, EP72xx, ELM72xx and EJ72xx.

## TwinCAT 3 Scope

TwinCAT 3 Scope is Beckhoff's graphic tool for signal analysis and data collection. As it is separated into two main components, View and Server, it is possible to display the signal curves of several systems distributed in the field in a central version of TwinCAT 3 Scope. Depending on the system, it is possible to browse, for example, the PLC, NC or directly in the connected EtherCAT I/Os, in order to select the corresponding variables. TwinCAT 3 Scope 3 provides the option to execute long-term recording, various trigger functionalities and cursors.

## Conclusion:

Thanks to the I/O components' optimal compatibility with the industrial PCs, the TwinCAT automation software, and the drive technology components, Beckhoff customers receive a perfectly harmonized automation solution.

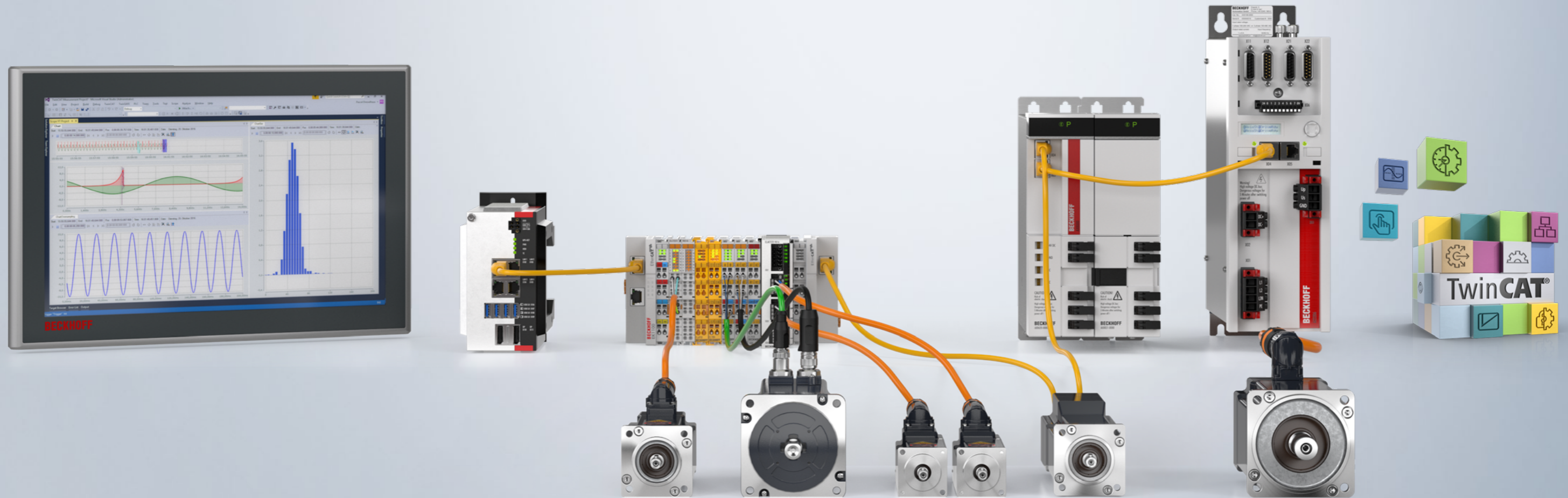

# Freedom in choice of architecture: TwinSAFE

### Safe Torque Off (STO)

Here, the STO (SS1) safety function is executed either by the local TwinSAFE Logic or via FSoE. These variants also have internal TwinSAFE Logic that enables the safety application to be executed on the drive controller.

### Safe Motion

Includes almost all advanced safety functions such as:

- stop functions (STO, SOS, SS1, SS2)
- speed functions (SLS, SSM, SSR, SMS)
- position functions (SLP, SCA, SLI)

- acceleration functions (SAR, SMA)
  - direction of rotation functions (SDlp, SDln)
- Furthermore, TwinSAFE Logic is integrated. This means that the TwinSAFE application can be run on the drive controller if required. The ELM72xx servomotor terminals support both the HIPERFACE DSL encoder and EnDat 3.0 feedback; HIPERFACE DSL can be used to implement safety applications up to performance level e.



In the field of drive technology, it's hard to imagine a solution without safety functionality. Therefore, the AMI81xx distributed servo drives are available with TwinSAFE STO/SS1 safety functions as an option.

## STO: Safe Torque Off

- STO safety function via internal TwinSAFE Logic or via FSoE
- safety application on the drive controller
- available in ELM72xx-9016 and AMI812x-x1xx

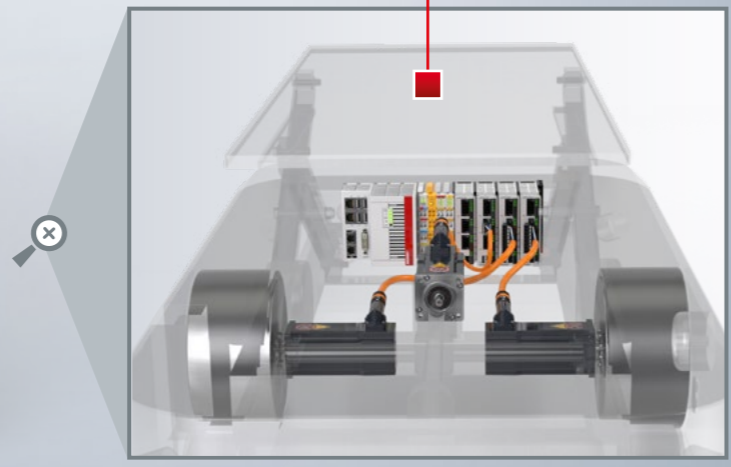
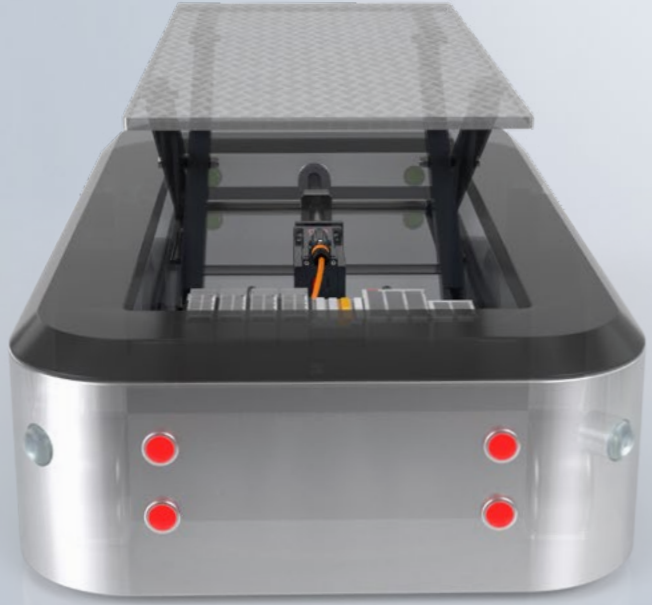

## Safe Motion

- advanced safety functions
- internal TwinSAFE Logic
- safety application on the drive controller
- available in ELM72xx-9018

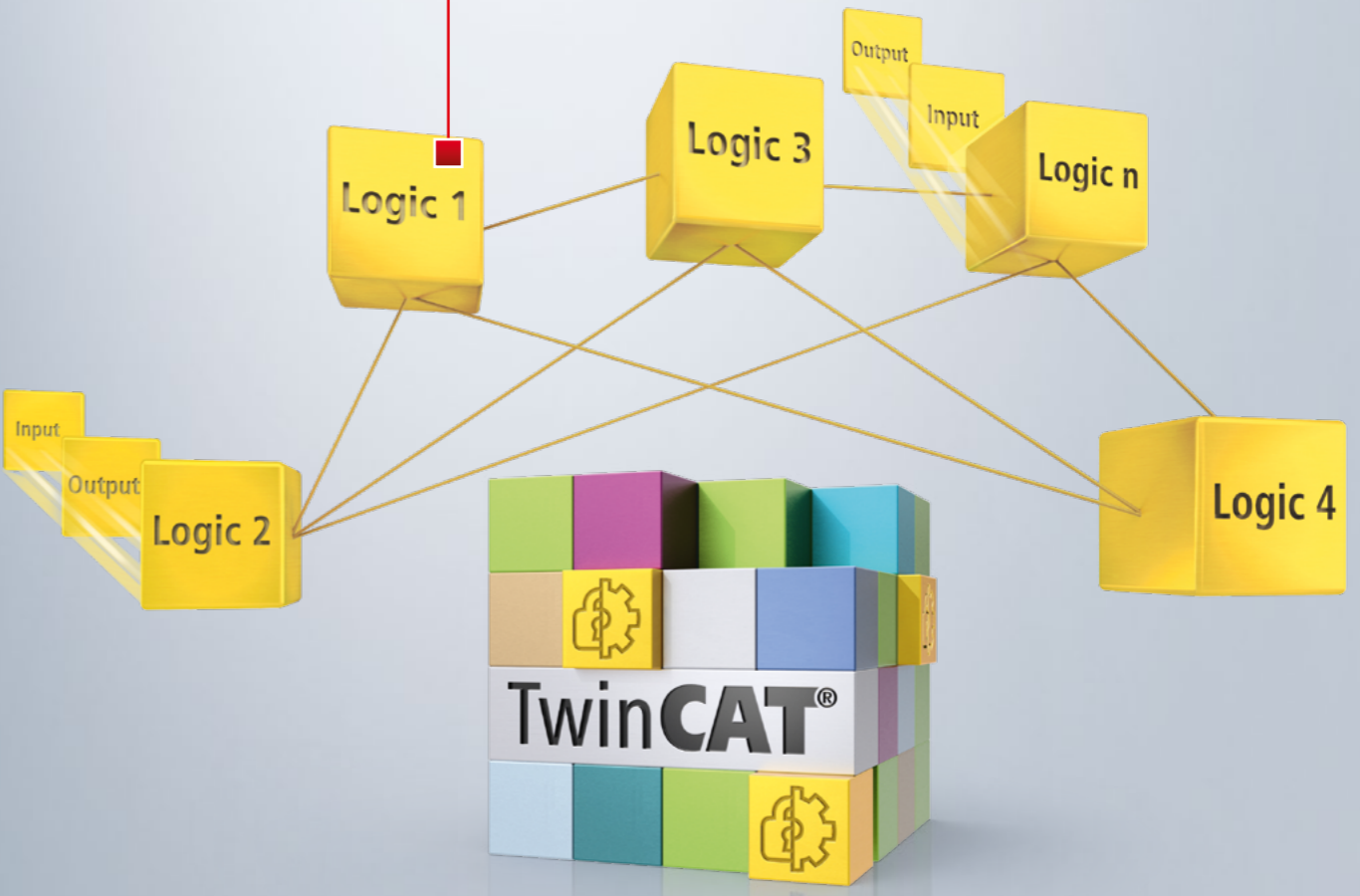





## More about Beckhoff



[Company profile](#)



[Global presence](#)



[Events & dates](#)



[Jobs](#)



[Products](#)



[Industries](#)



[Support](#)

### **Beckhoff Automation GmbH & Co. KG**

Hülshorstweg 20

33415 Verl

Germany

Phone: + 49 5246 963-0

[info@beckhoff.com](mailto:info@beckhoff.com)

[www.beckhoff.com](http://www.beckhoff.com)

Beckhoff®, TwinCAT®, TwinCAT/BSD®, TC/BSD®, EtherCAT®, EtherCAT G®, EtherCAT G10®, EtherCAT P®, Safety over EtherCAT®, TwinSAFE®, XFC®, XTS® and XPlanar® are registered trademarks of and licensed by Beckhoff Automation GmbH. Other designations used in this publication may be trademarks which, if used by third parties for their own purposes, could violate the rights of the owners.

© Beckhoff Automation GmbH & Co. KG 11/2022

The information provided in this brochure only contains general descriptions or characteristics of performance which may not always apply as described in actual application, or which may change as a result of further development of the products. An obligation to provide the respective characteristics shall only exist if expressly agreed in the terms of contract.

We reserve the right to make technical changes.