

Narrow-band RF Networks

Campbell Scientific's radiotelemetry (RF) systems support data retrieval from moving vehicles or remote areas where communication via cables is impractical.

Data from field stations are retrieved at a computer base station. The base station can communicate with up to 254 remote stations over a single frequency. A phone modem can also access an RF network.

Field stations and repeater stations can be located to allow communication over long distances and rough terrain. The maximum distance between any two communicating stations is approximately 25 miles and must be line-of-sight (unobstructed by mountains, large buildings, etc.). Longer distances and rough terrain may require intermediate repeater station(s).

RF data transmission hardware includes radios, antennas, and radio modems. Power at the field and repeater stations is provided by sealed rechargeable batteries trickle-charged by solar or ac power.



A remote meteorological station can transmit data via radio telemetry to a base station.

Features

- Measurement sites can be located in areas without phone lines or cellular coverage
- Eliminates cables and cable costs
- Supports local and remote data retrieval
- Allows remote control of datalogger functions

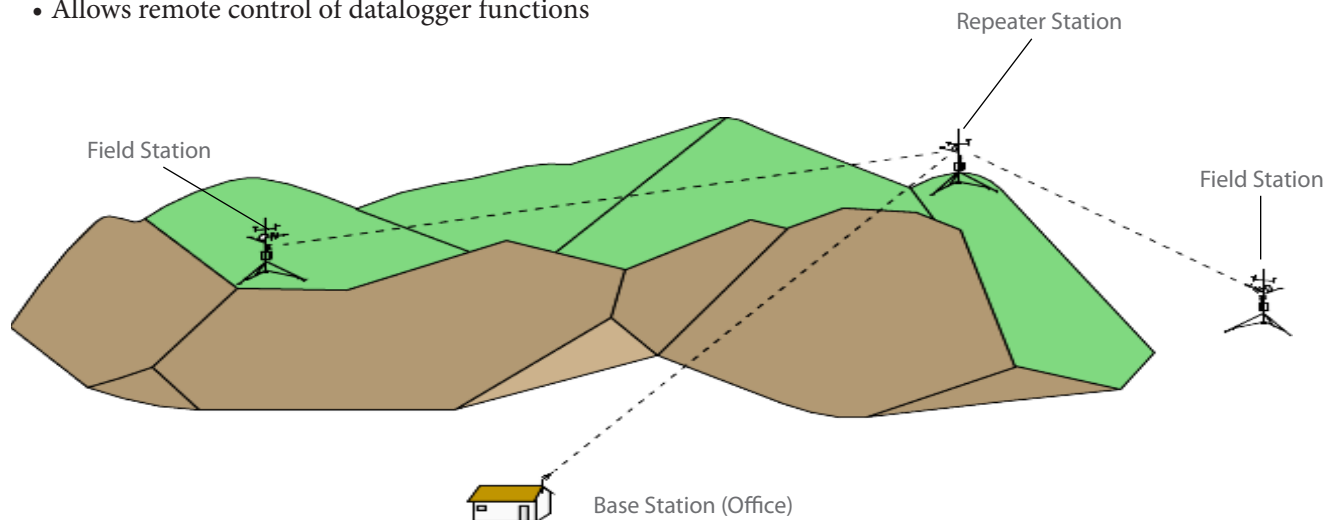

Our RF networks require line-of-sight transmission. The mountain in this drawing obstructs line-of-sight with the base station. Use of the repeater station allows the base station to receive data from the field stations.

Field Stations

Field stations are located at the measurement site. They can also act as a repeater to extend the range of the network. Each field station should contain:

- Datalogger
- Power supply (5 Ahr minimum)
- RF modem such as the RF500M
- Radio transceiver such as the RF310, RF312, or RF313
- Antenna (directional or omnidirectional)
- Antenna cable
- Environmental enclosure
- Tripod or tower
- Sensors and sensor mounts

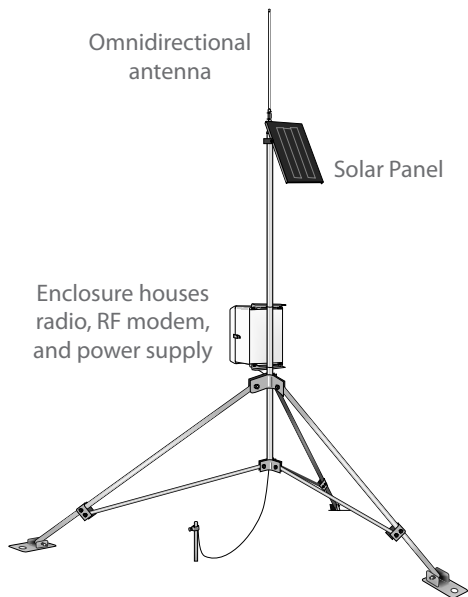
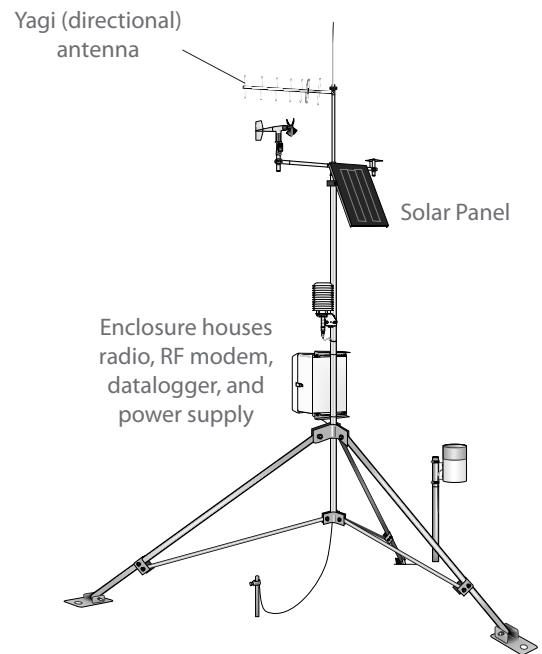

Repeater Stations

Repeater stations act as communication relays between stations that cannot communicate directly due to distance or obstacles. Repeater stations should contain:

- RF modem such as the RF500M
- Radio transceiver such as the RF310, RF312, or RF313
- Rechargeable power supply with charging regulator and null modem ports such as an A100 adapter connected to a CH100 regulator and a user-supplied rechargeable battery
- Omnidirectional antenna
- Antenna cable
- Environmental enclosure
- Tripod or tower

Computer Base Stations

Base stations support attended and unattended retrieval of the field station's data and provide communication error checking and data processing. AC power is required. Base stations should contain:

- A base station package such as the RF500B
- Radio transceiver such as the RF310, RF312, or RF313
- PC running LoggerNet Datalogger Support Software
- Antenna (directional or omnidirectional)
- Antenna cable

Portable Base Station

For some customers, it is desirable to have a portable base station. The portable base station is helpful for setting up large radiotelemetry networks or troubleshooting RF network communication problems. A portable base station enables any of the field or repeater stations to act as a base station. Portable base stations require the following equipment:

- Laptop computer running LoggerNet Datalogger Support Software
- Power Supply

FCC Licensing

Before ordering radios and antennas, you must submit an application to the Federal Communications Commission (FCC) to acquire an FCC license and be assigned a frequency range. To file for an FCC license on-line, go to <http://wireless.fcc.gov/uls> and register. You can then log in and apply for the license. Canadian DOC approval is available for radios in the 138 to 174 MHz and 403 to 470 MHz frequency bands only.

Power Considerations

The location of your site, number of calls, and length of calls affect the power requirements of your system. Information on analyzing your system's power requirements is provided in our Power Supply brochure and application note. You can also contact an applications engineer who will help you determine an appropriate power supply for your system.

Phone-to-RF Base Station

A phone-to-RF base station provides phone access to a distant radiotelemetry network.

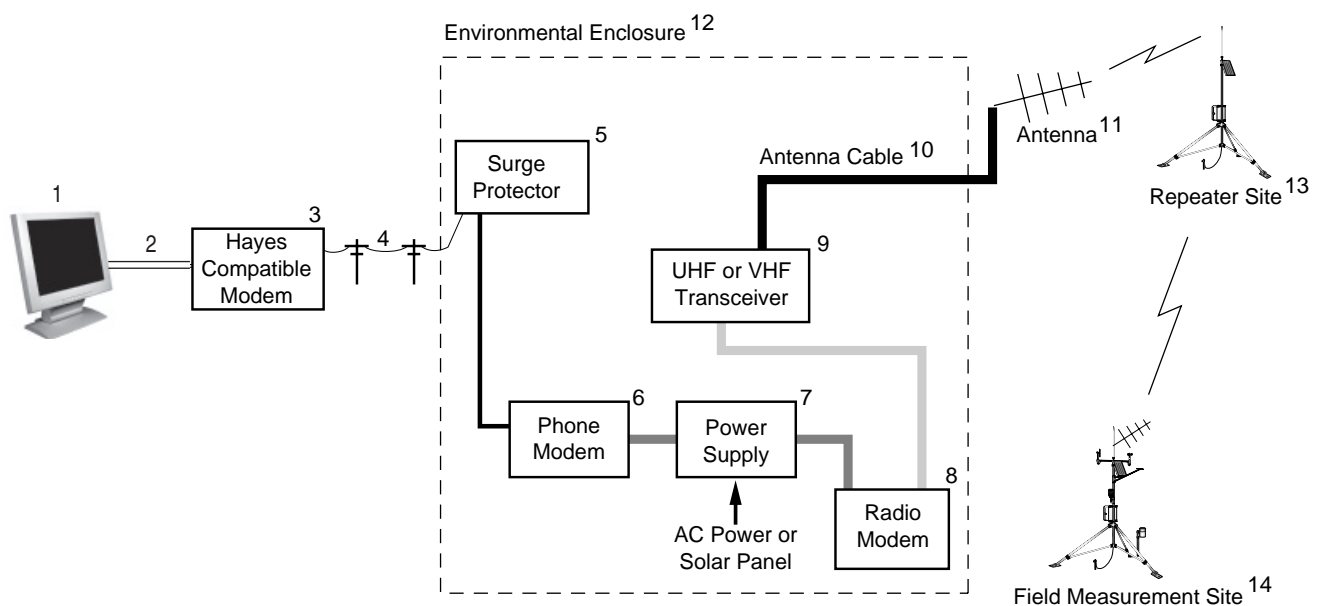

This system requires the following equipment:

1. PC running LoggerNet software (PC400 software does not support combined communications, and therefore cannot be used)
2. 7026 serial cable or equivalent
3. Customer-supplied Hayes-compatible modem
4. Connection to a switched telephone network
5. Telephone surge protector if the telephone company has not installed a surge protector
6. COM220 Telephone Modem (includes SC12 cable)
7. Rechargeable power supply with regulator and null modem port
8. RF Modem such as the RF500M
9. Radio transceiver such as the RF310, RF312, or RF313
10. Antenna cable
11. Antenna
12. Enclosure/Mounts/Tripod
13. Repeater Site(s)
14. Field measurement site(s)

Compatibility

Radios

Narrowband radios listed on our price lists are the RF310 148-174 MHz VHF Transceiver, RF312 440-470 MHz UHF Transceiver, and RF313 400-430 MHz UHF Transceiver. The RF310 series can be used with our RF500M Radio Modem, RF500B Base Station, RF310M Radio Modem, and RF310B Base Station. Other radios, RF modems, or RF base stations (e.g., P50, RF95, RF95A, RF232) are not compatible.

Dataloggers that support the RF310-series radio transceivers include our CR800, CR850, CR1000, CR3000, CR7, CR510, CR10(X), and CR23X. The RF310 series is not compatible with our CR200-series, CR5000, or CR9000(X) dataloggers.

Radio Modems and Base Stations

The RF500M and RF500B are compatible with PakBus® dataloggers (e.g., CR800, CR1000, CR3000). They work with Midland radios (i.e., RF310, RF312, RF313), DataRadio radios, or any radio and modem combination that outputs a demodulated byte stream via RS-232.

The RF500M and RF500B can be in networks with other Campbell Scientific radio modems (e.g., RF310M) and base stations (e.g., RF310B) as long as the other radio modems and base stations use the -TD PROM. Dataloggers connected to the other RF Modems or Base Stations must be PakBus versions.



The RF310-series radios are manufactured by Midland. They meet the NTIA narrowband and FCC refarming requirements for transmission.



The versatile RF500M can serve as a field modem connected to a datalogger and as a standalone repeater not connected to a datalogger.

More Information

Specifications and additional information are provided in the brochures and manuals for the radios, modems, and base stations.

