

BARTHOD

PUMPS

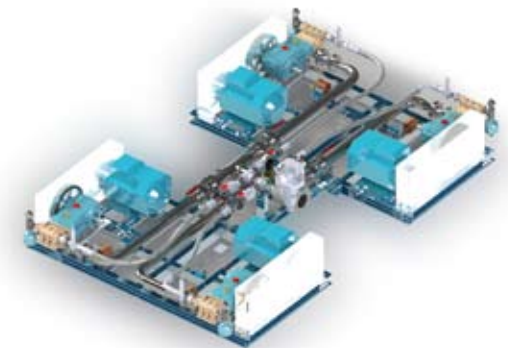

BARTHOD PUMPS BROCHURE [\(READ MORE\)](#)

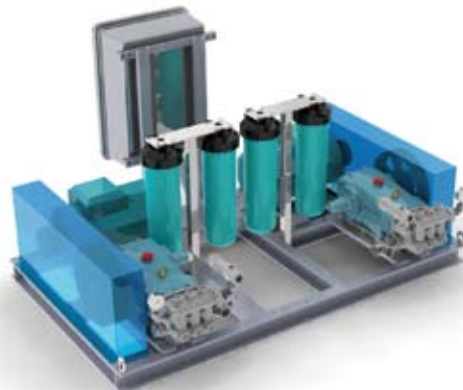

BROCHURE BARTHOD PUMPS [\(VOIR LA SUITE\)](#)



BARTHOD PUMPS BROSCHÜRE [\(LESEN SIE MEHR\)](#)



HYDRAULIC ENGINEERING

DESIGN AND MANUFACTURING OF
HIGH PRESSURE MOTOPUMP UNITS



APPLICATION: HYDRODYNAMIC CLEANING, OSMOSIS, PRESSURE TESTING, SPRAYING, INJECTION

COOLING DOWN OF MACHINING TOOL
20 à 35 L/MIN – 350 BARS – 30 KW

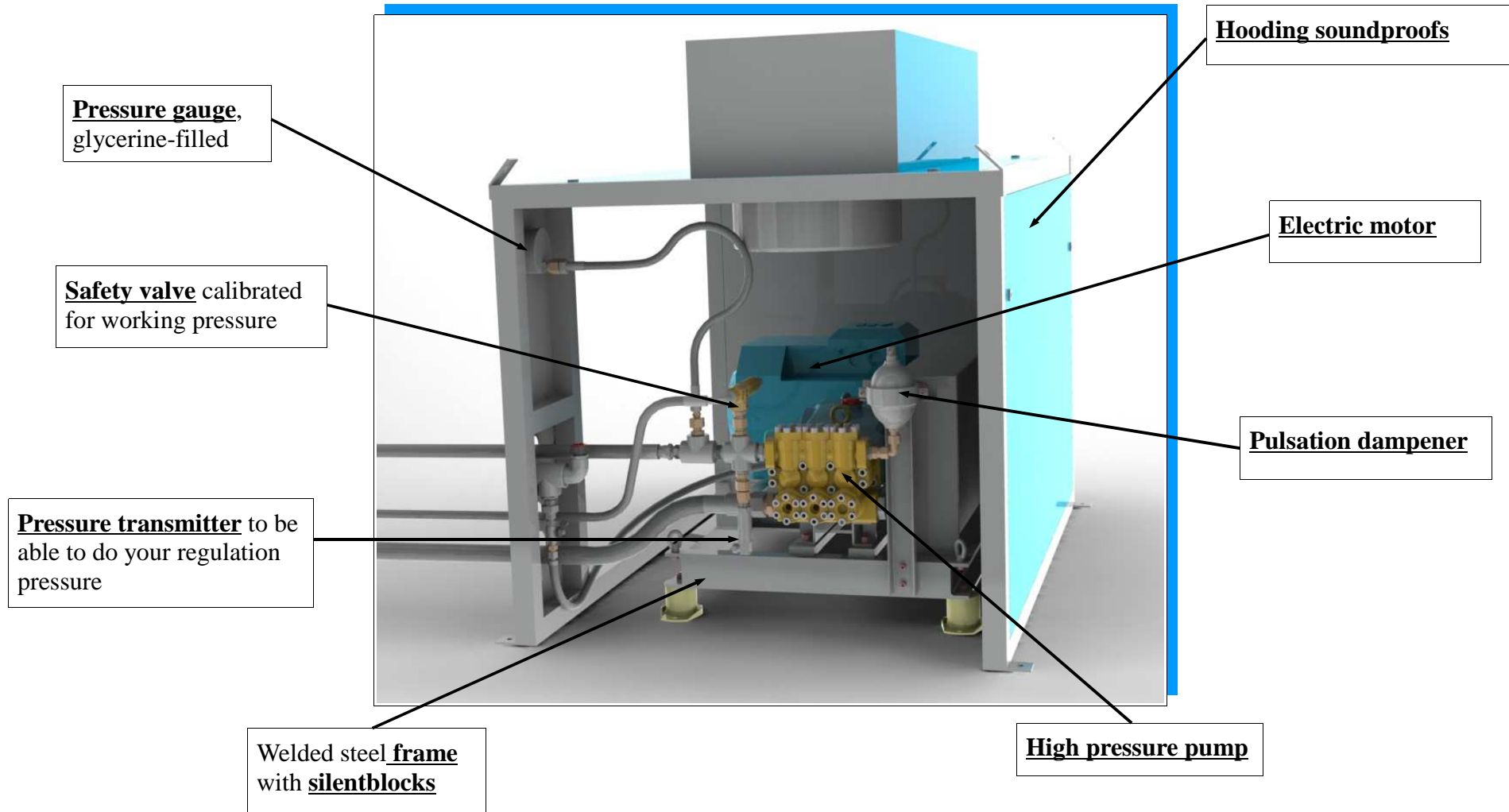

MISTING SYSTEM – 100 L/MIN – 60 BARS – 15 KW

Inlet filter with clogging indication

Electric chest

Electric motors ATEX

Safety valve calibrated for working pressure

Drive system by pulleys and V belts with protective cover

High pressure pumps in parallel

Pressure gauge, glycerine-filled

Double welded steel **frame**

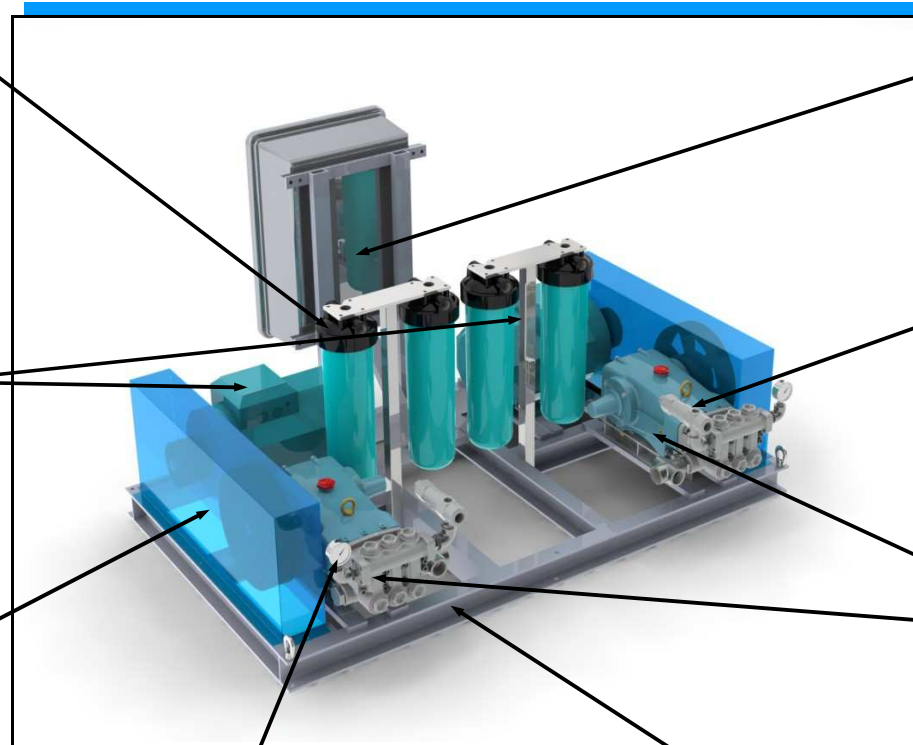

PRESSURE TESTING ON TROLLEY
15 L/MIN – 100 BARS – 3 KW

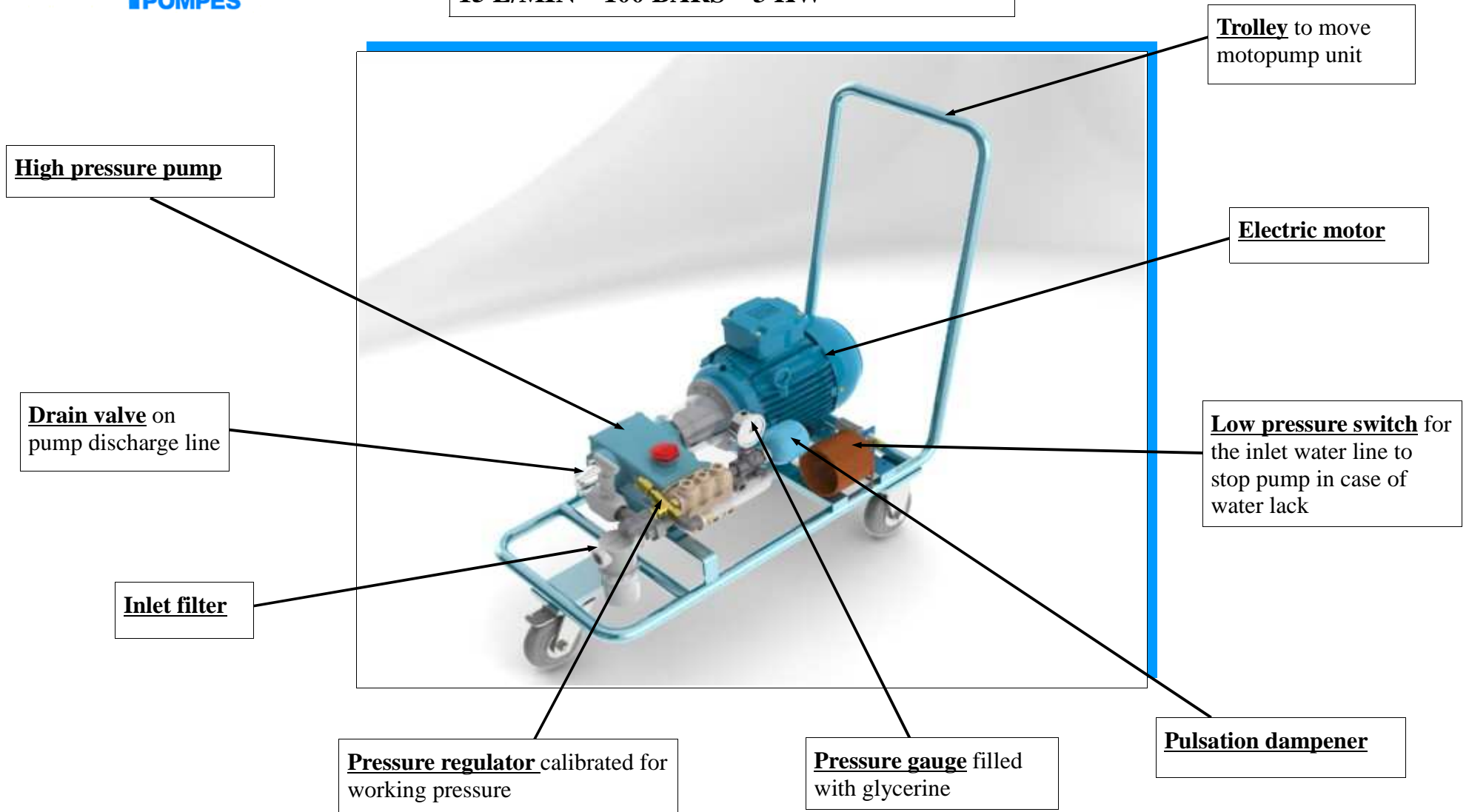

INDUSTRIAL CLEANING – 400 L/MIN – 80 BARS

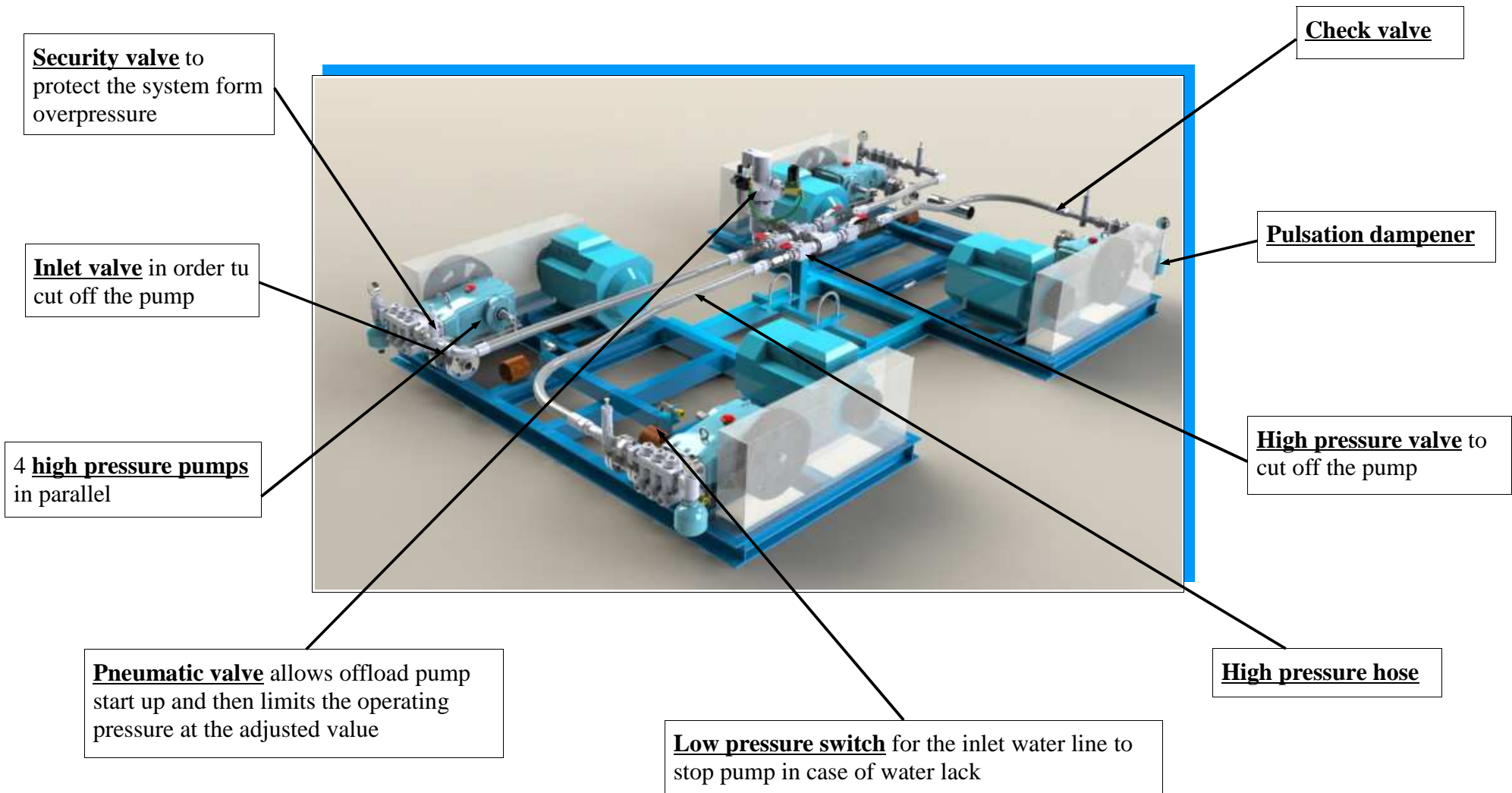

INDUSTRIAL CLEANING – 170 L/MIN – 80 BARS – 30 KW

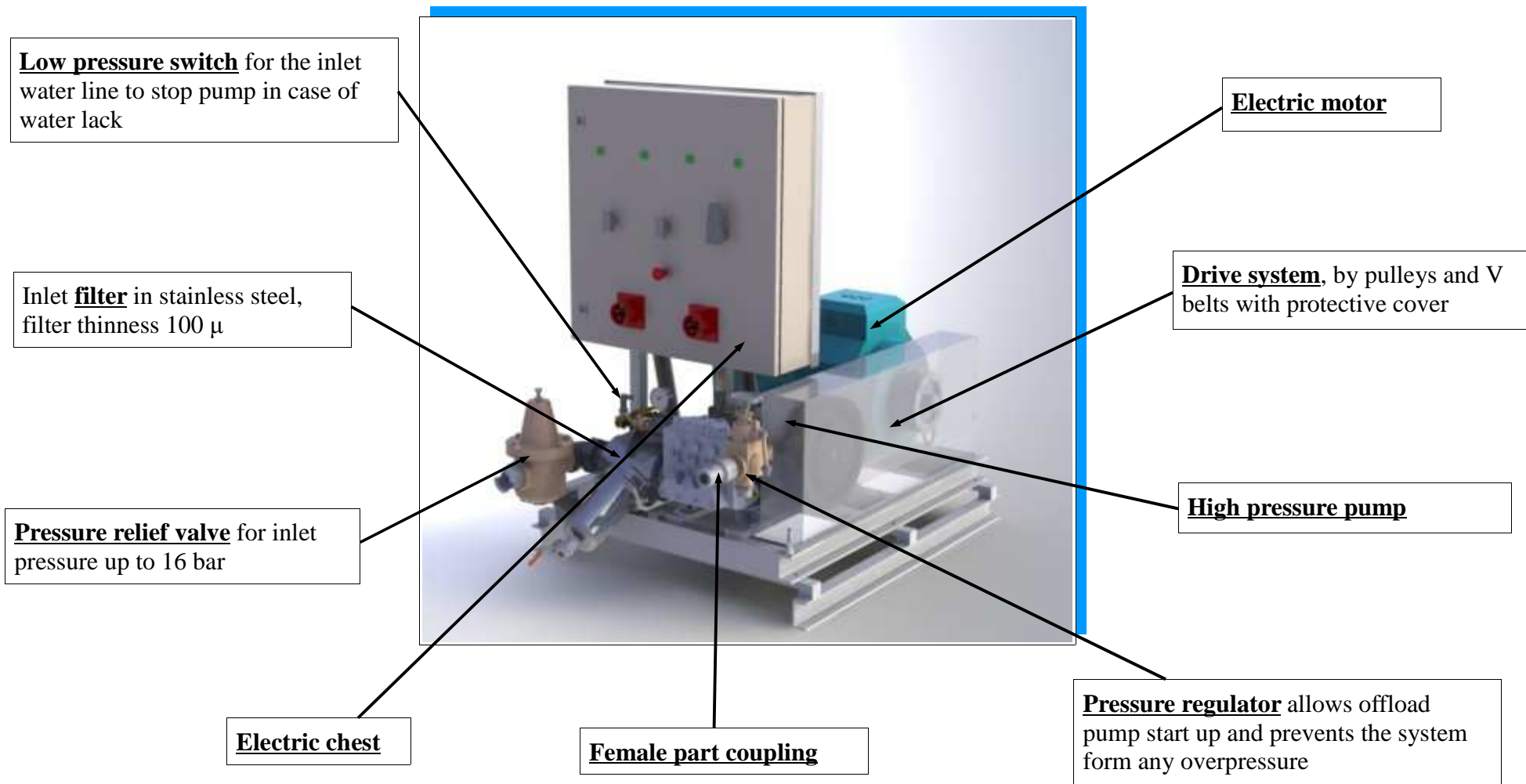

TEST PUMP WITH DIESEL ENGINE
13 L/MIN – 40 BARS – MOTOR 5CV

Safety valve, calibrated for working pressure

Diesel engine

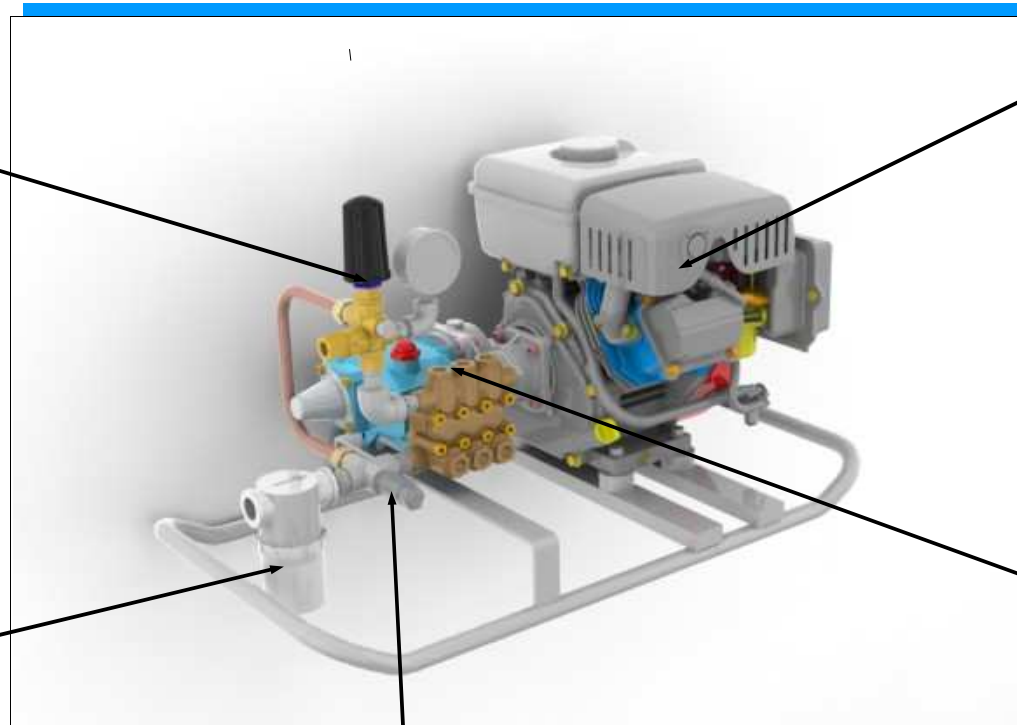

Inlet filter

High pressure pump

Thermostat to stop pump in case of high temperature

7 L/MIN - 350 BARS – 7,5 KW

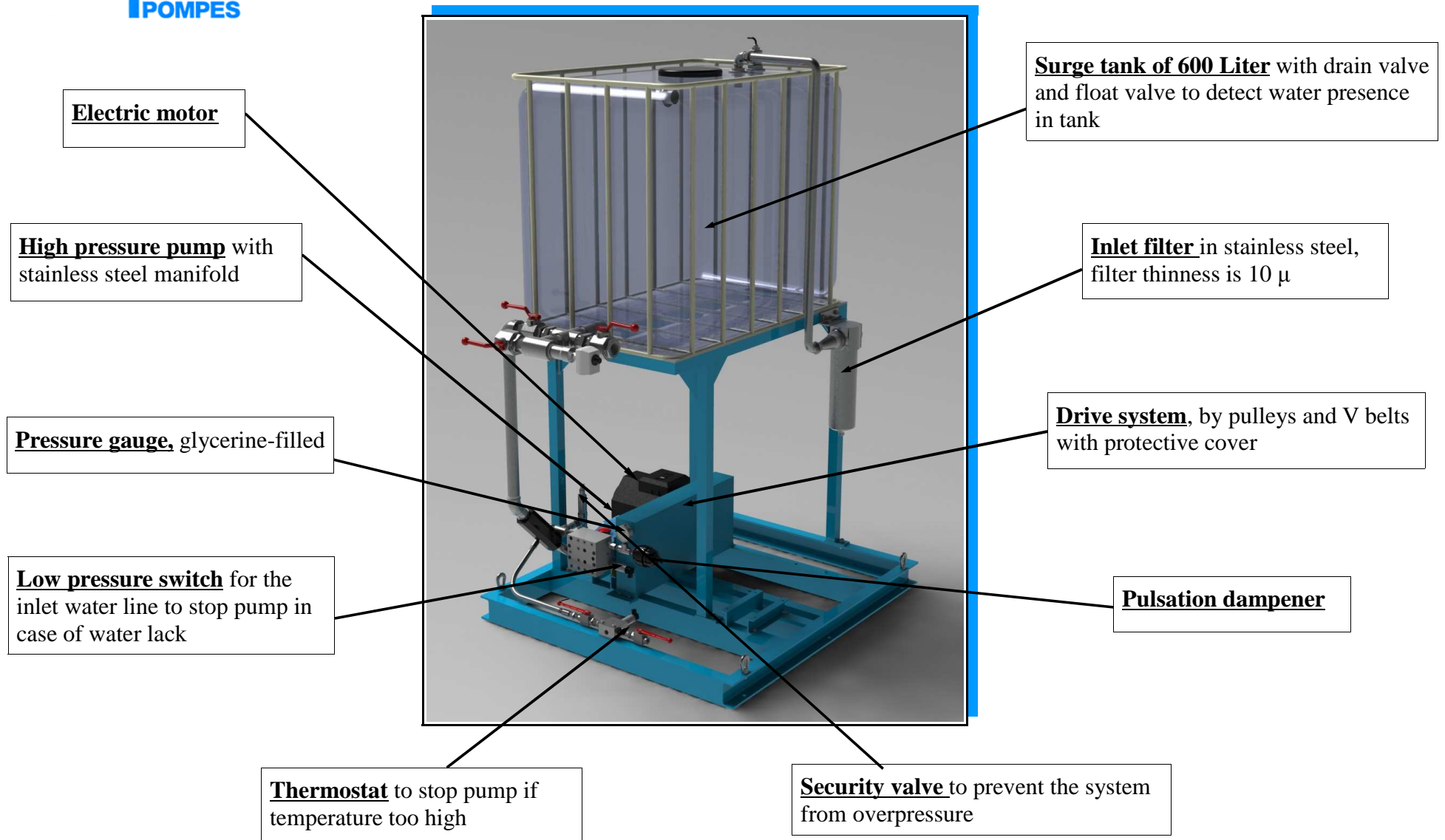

87 L/MIN – 120 BARS – 15 KW

Drive system by pulleys and V belts with protective cover

Electric motor ATEX

Welded steel frame
« umbrella » to protect from rain

Check valve

Pressure gauge,
glycerine-filled

Safety valve calibrated for working pressure

Pulsation dampener

High pressure pump

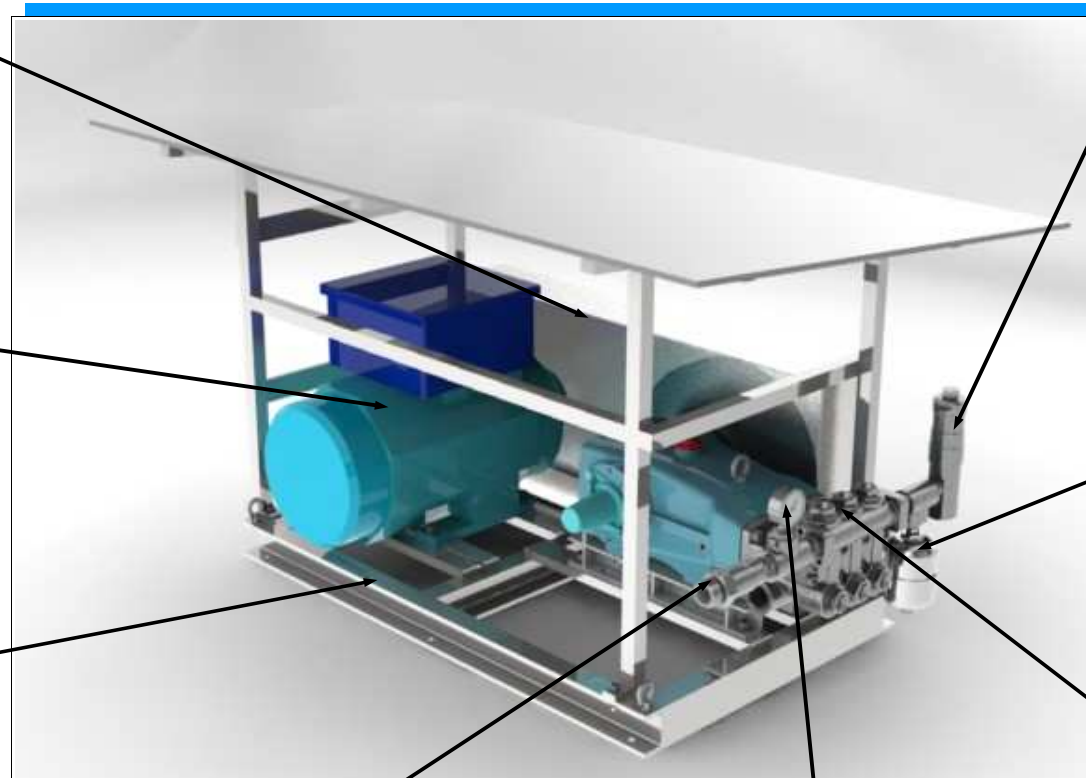

BARTHOD POMPES

INGENIERIE HYDRAULIQUE

CONCEPTION DE GROUPES
MOTOPOMPES HAUTE PRESSION



7 lmin - 400 bars - 7,5 kW

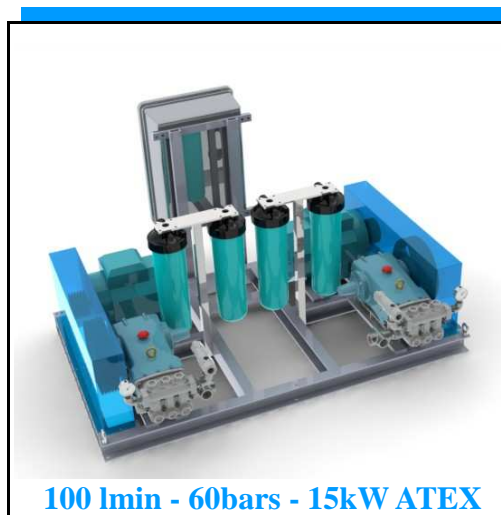

100 lmin - 60bars - 15kW ATEX

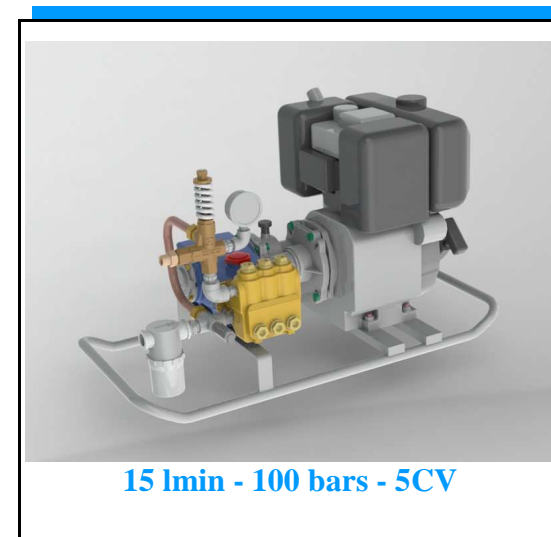

15 lmin - 100 bars - 5CV

APPLICATION: NETTOYAGE HYDRODYNAMIQUE, OSMOSE, EPREUVE HYDROSTATIQUE, BRUMISATION, INJECTION

**LUBRIFICATION DE MACHINES OUTILS –
20 à 35 L/MIN – 350 BARS – 30 KW**

Manomètre bain de glycérine et équipé d'un flexible HP pour montage sur capot d'insonorisation

Caisson d'insonorisation pour niveau de pression acoustique

Moteur électrique

By-pass assure la régulation de pression

Bouteille antipulsatoire

Capteur de pression pour la commande de la régulation de pression

Châssis fixe, mécanosoudé, monté sur support antivibratoire

Pompe HP à trois pistons

Soupape, tarée à la pression de service

Vanne BP d'isolement de la pompe

4 pompes HP à trois pistons en parallèle

Valve électropneumatique de mise en pression et de régulation

Contact pressostatique avec serpentín de protection

Clapet anti-retour

Bouteille antipulsatoire

Vanne HP à boisseau sphérique d'isolement de la pompe

Flexible haute pression, pour le raccordement au collecteur de refoulement

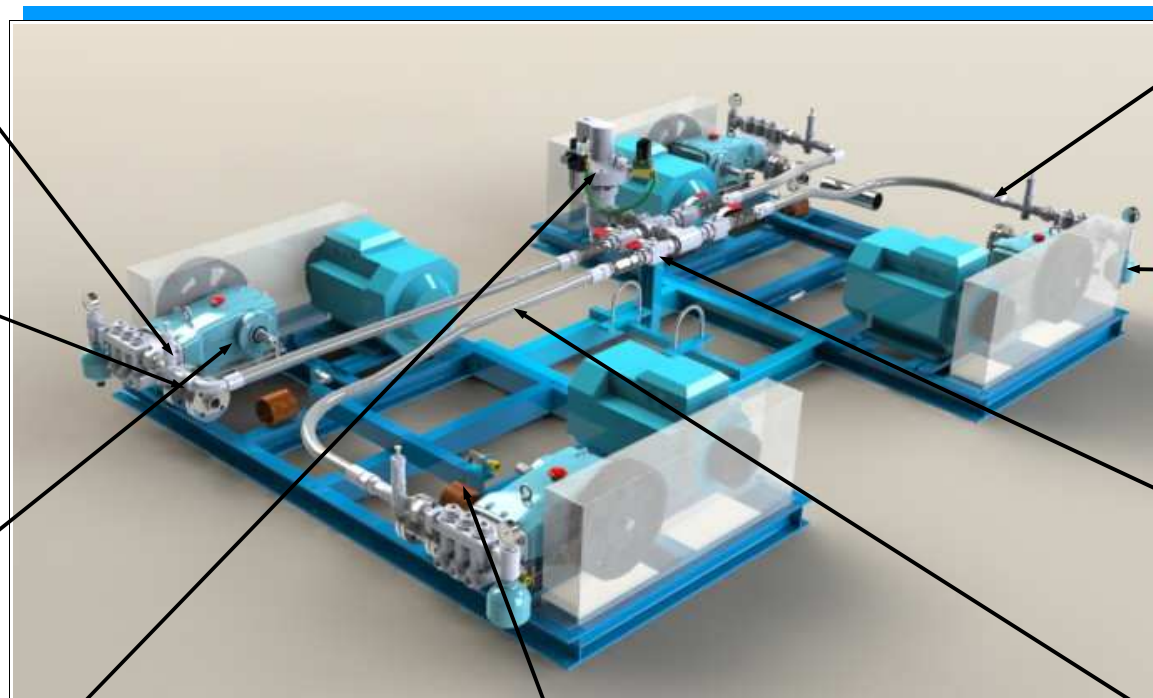

7 L/MIN - 350 BARS – 7,5 KW

Moteur électrique optimisé pour variation de fréquence

Pompe HP, culasse en inox

Manomètre

Capteur de pression pour commander l'arrêt de la pompe en cas de pression insuffisante

Thermostat pour commander l'arrêt de la pompe

Réservoir, capacité 600 litres avec un dispositif de mesure du niveau du réservoir

Filtre inox, basse pression, finesse de filtration 10 μ

Soupape, assure la sécurité de la pompe

Transmission par courroies trapézoïdales, avec capot de protection

Bouteille antipulsatoire

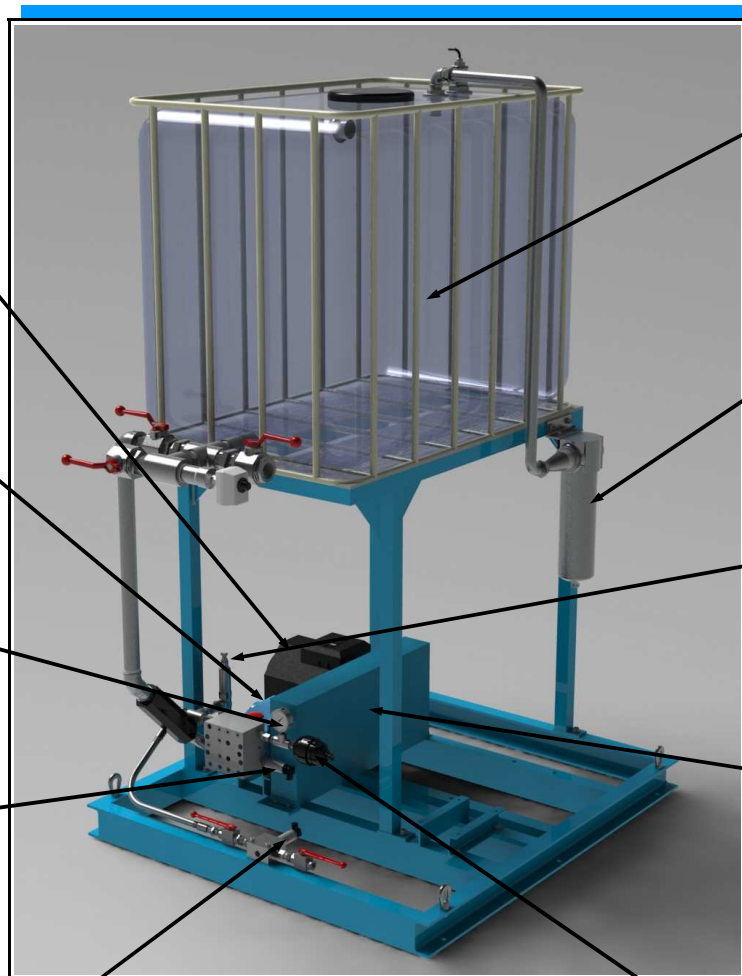

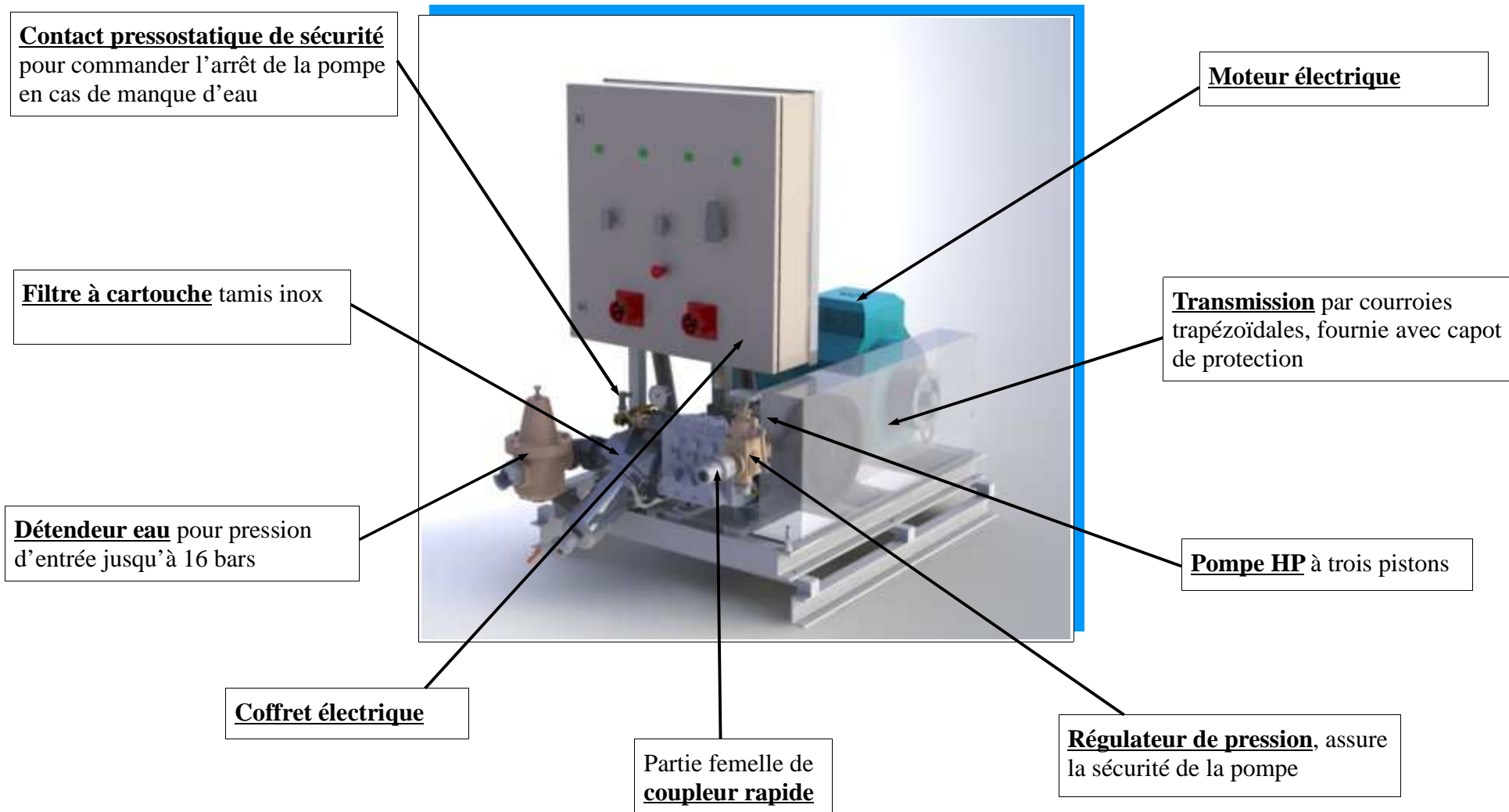

GROUPE D'EPREUVE HYDRAULIQUE
15 L/MIN – 100 BARS – 3 KW

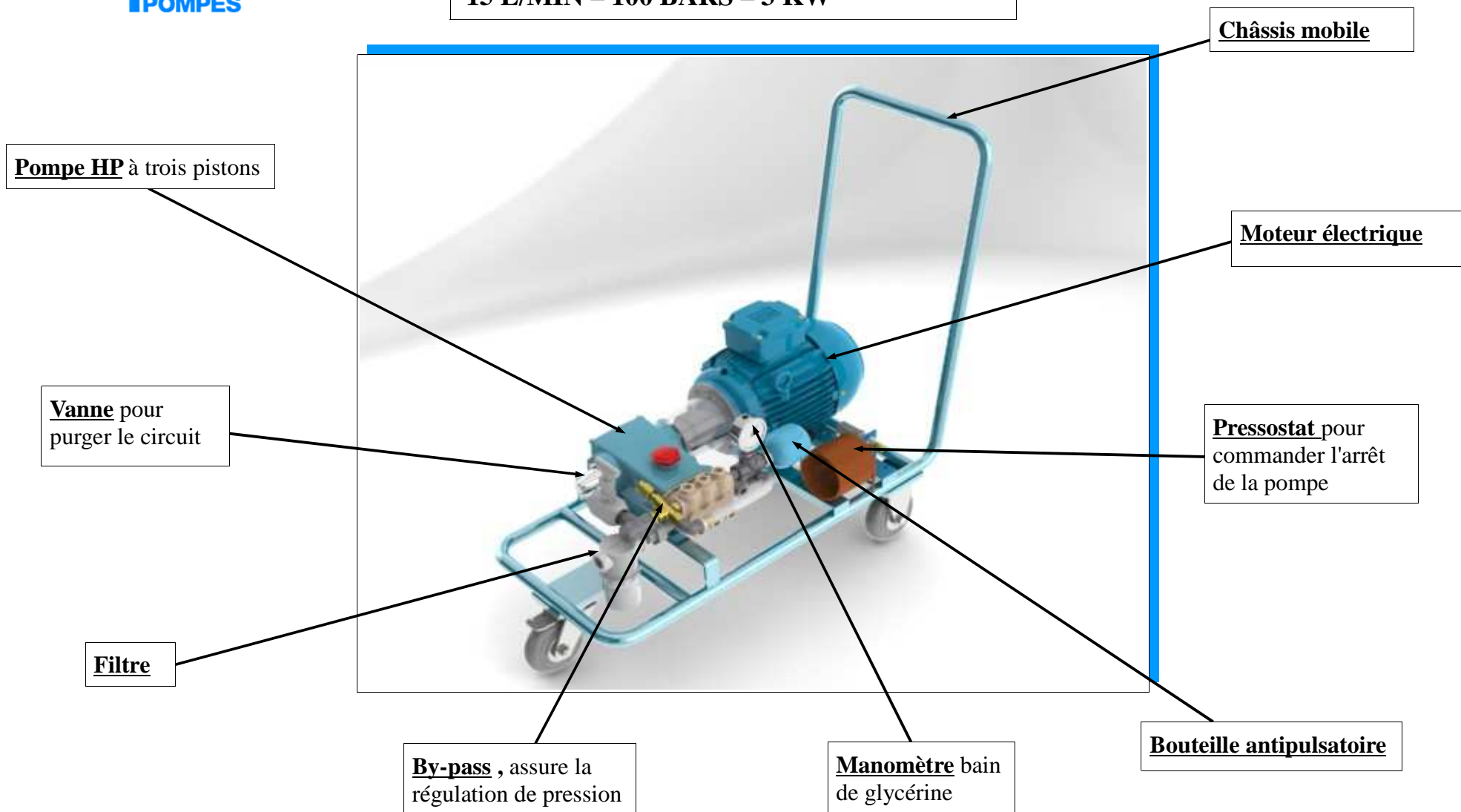

**GRUPE D'EPREUVE HYDRAULIQUE
13 L/MIN – 40 BARS – MOTEUR 5CV**

By-pass, assure la
régulation de pression

Moteur thermique
Essence ou Diesel

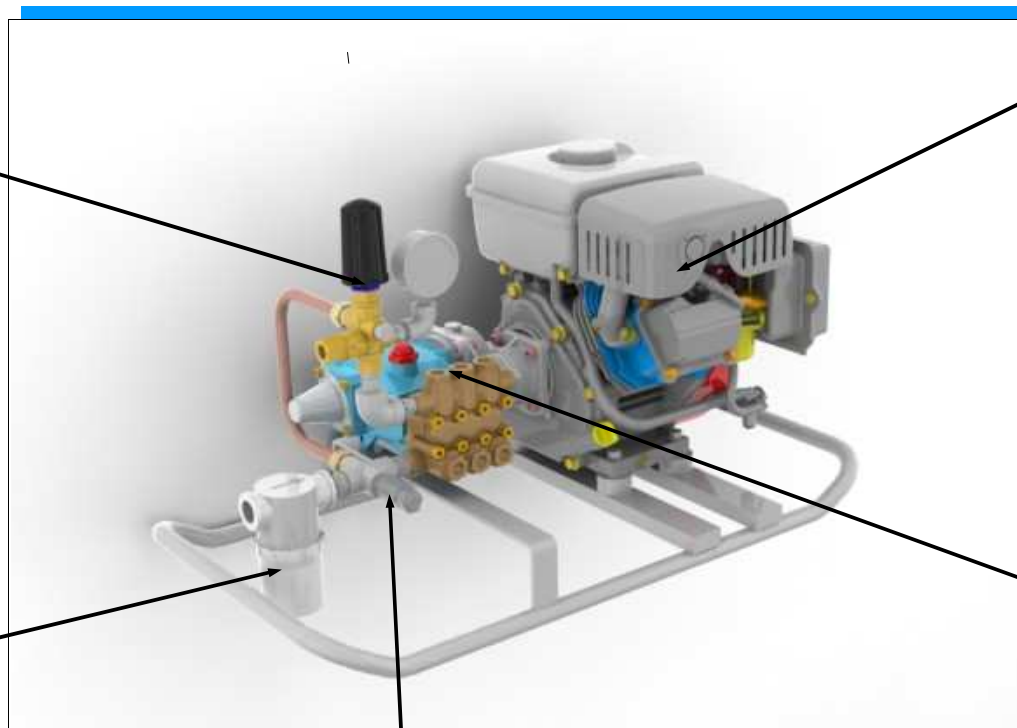

Pompe HP à trois
pistons

Filtre en amont de
la pompe

Thermostat pour commander
l'arrêt de la pompe

BRUMISATION – 100 L/MIN – 60 BARS – 15 KW

Filtre à poche avec l'indicateur de colmatage

Armoire électrique

Moteurs électriques ATEX

Châssis double mécano-soudé

Transmission par poulies-courroies avec son carter de protection

Pompes HP ATEX en parallèle

Manomètre, à bain de glycérine

Soupape de sécurité

87 L/MIN – 120 BARS – 15 KW

Transmission par courroies trapézoïdales, fournie avec capot de protection

Moteur électrique ATEX

Châssis « parapluie », fixe, mécano soudé

Clapet anti-retour

Manomètre à bain de glycérine

Régulateur, taré à la pression de service, assure la régulation de pression

Bouteille antipulsatoire

Pompe HP

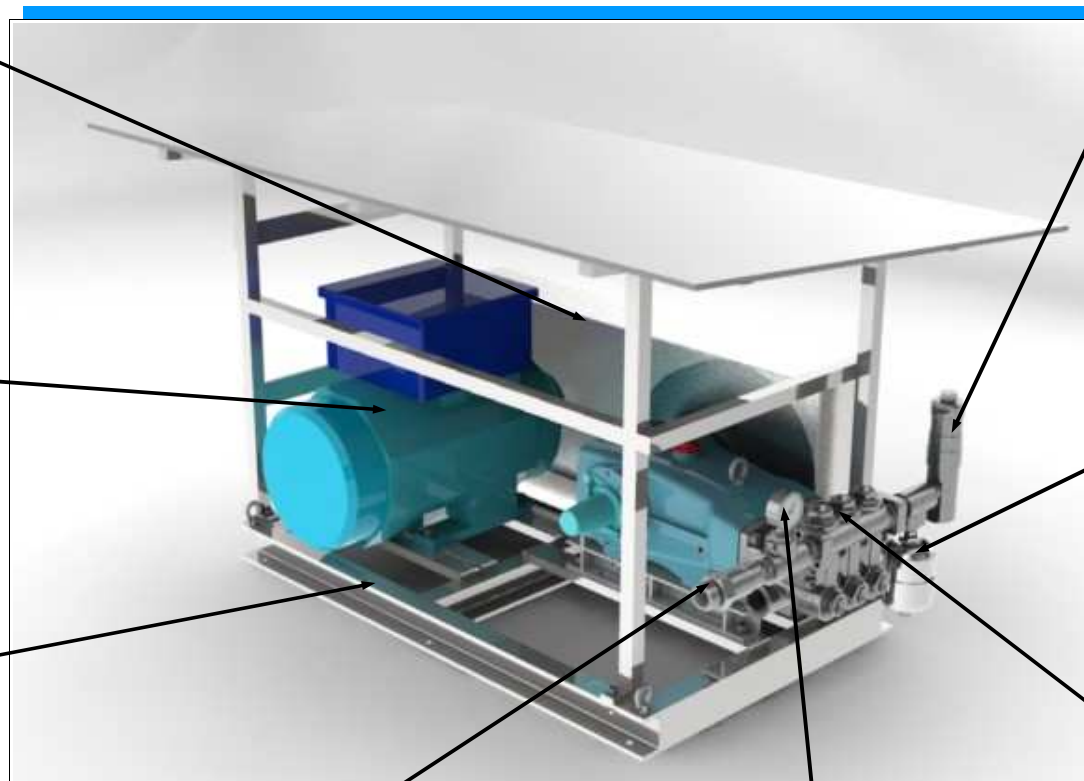

BARTHOD POMPES

HYDRAULISCHE ENGINEERING
KONZEPTION DEN PUMPENAGREGGATEN



ANWENDUNGEN: INDUSTRIELREINIGUNG, OSMOSE, PRUEFPUMPENAGGREGAT, SPUEHREN, INJEKTION

COOLING DOWN OF MACHINING TOOL
20 à 35 L/MIN – 350 BARS – 30 KW

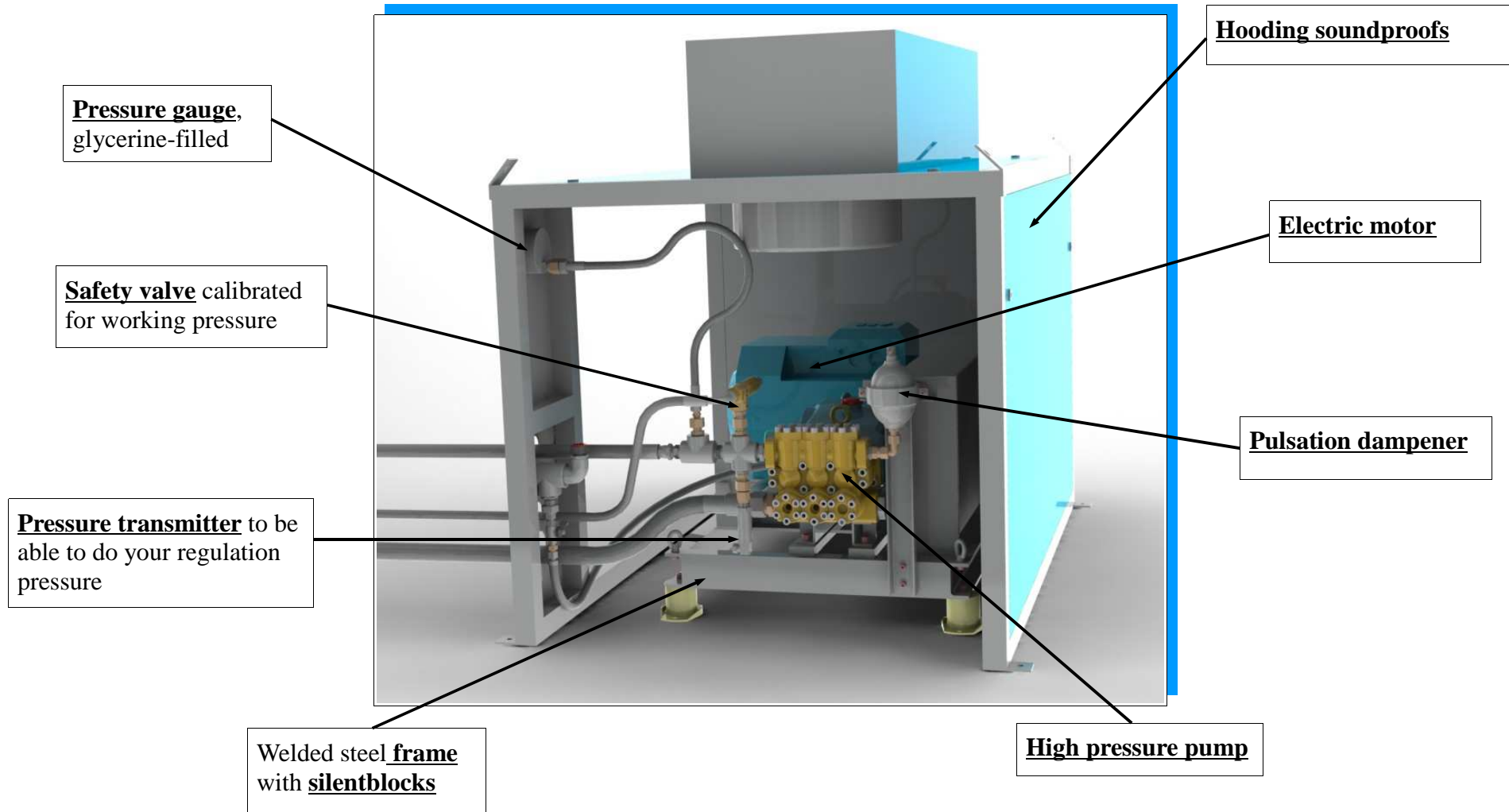

MISTING SYSTEM – 100 L/MIN – 60 BARS – 15 KW

Inlet filter with clogging indication

Electric chest

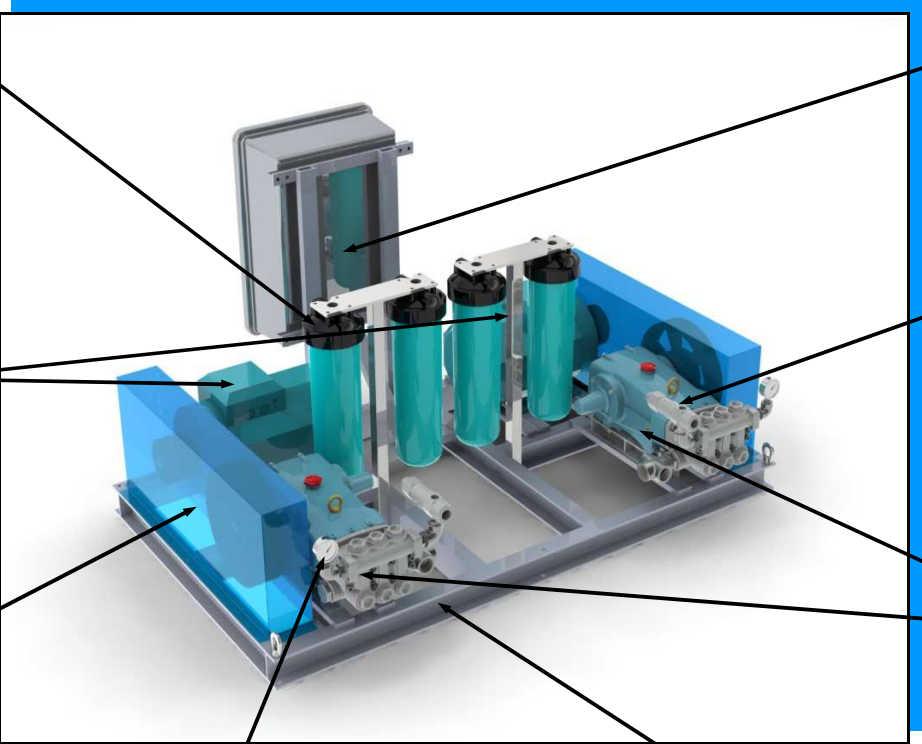

Electric motors ATEX

Safety valve calibrated for working pressure

Drive system by pulleys and V belts with protective cover

High pressure pumps in parallel

Pressure gauge, glycerine-filled

Double welded steel **frame**

PRESSURE TESTING ON TROLLEY
15 L/MIN – 100 BARS – 3 KW

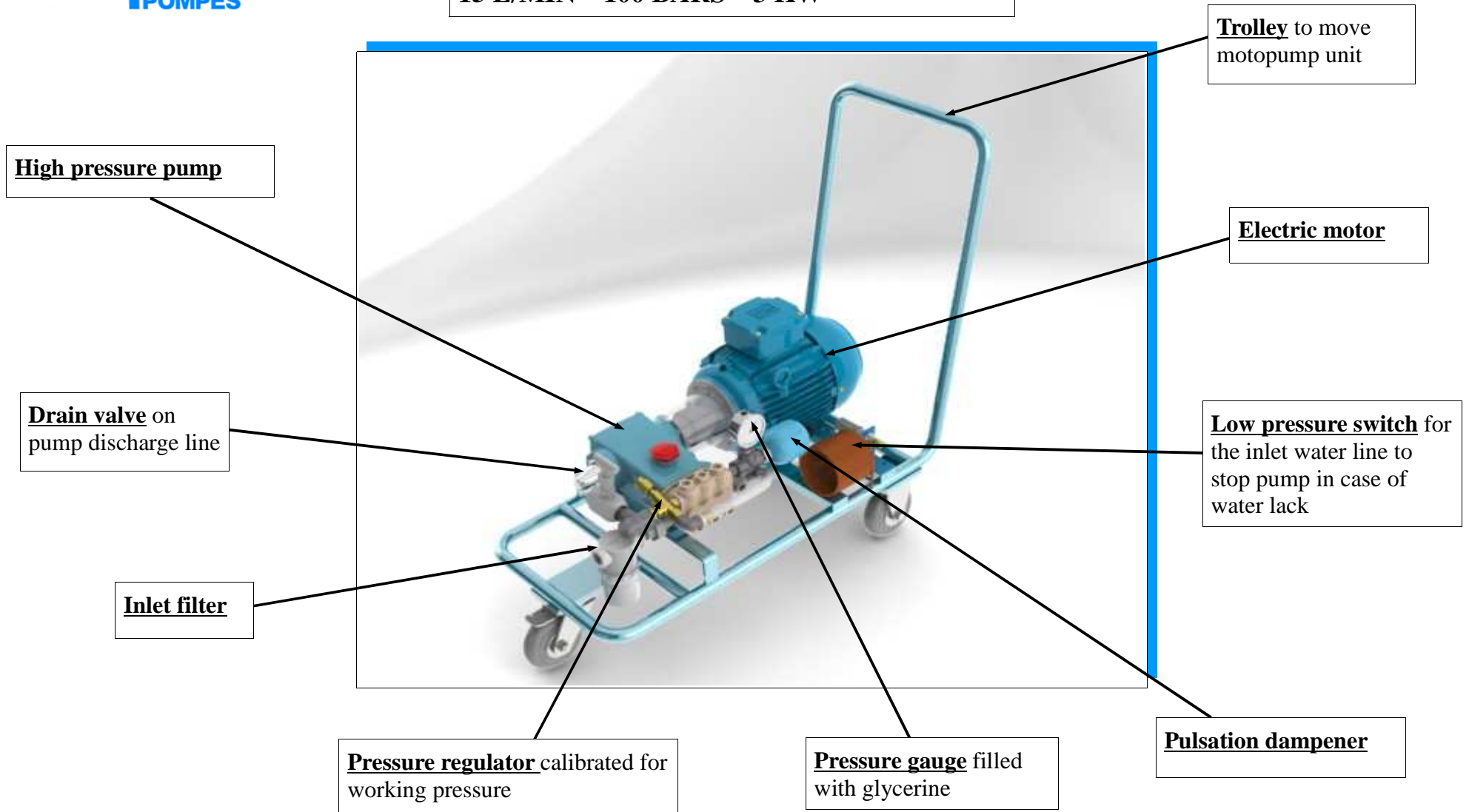

INDUSTRIAL CLEANING – 400 L/MIN – 80 BARS

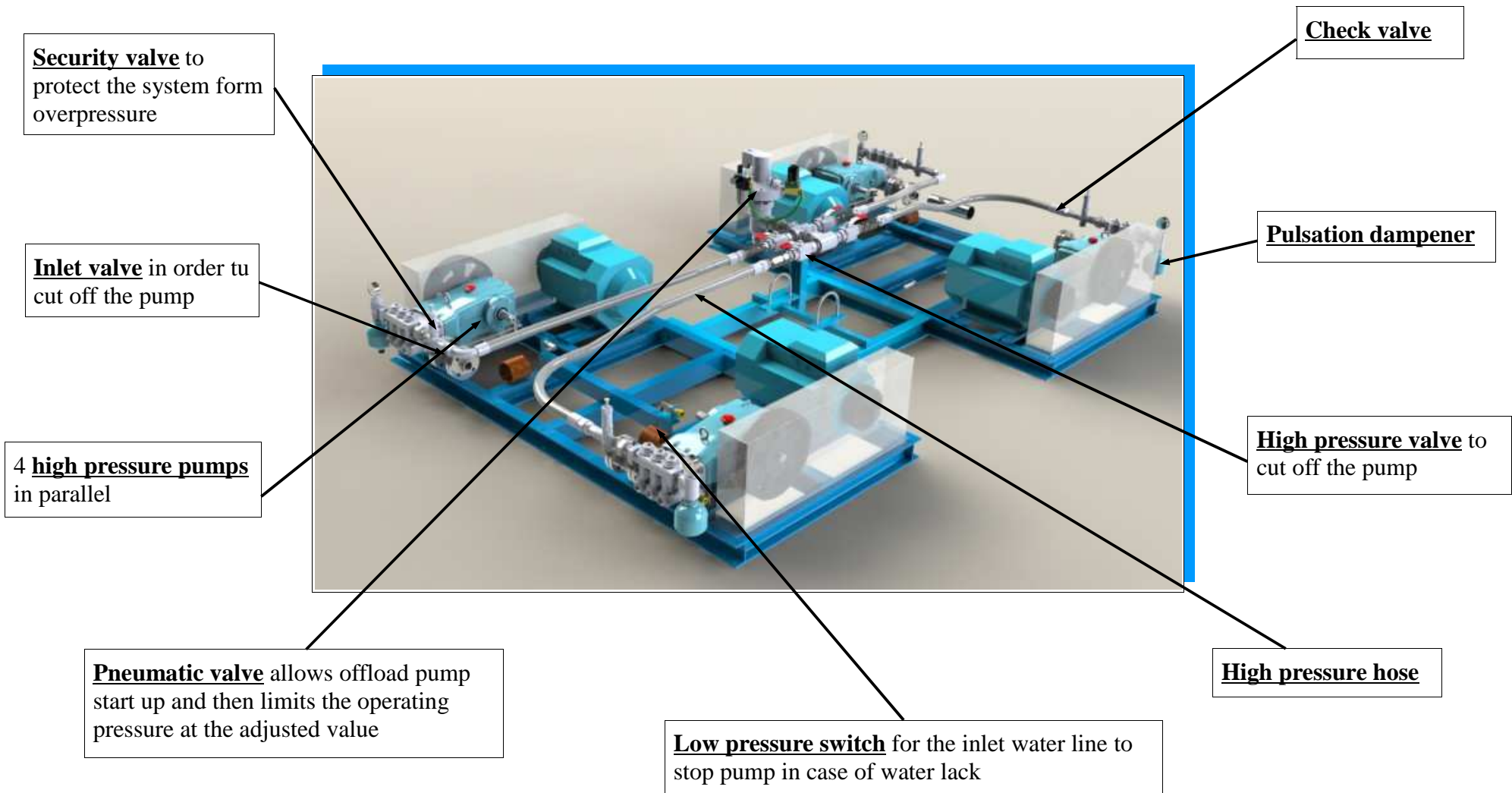

INDUSTRIAL CLEANING – 170 L/MIN – 80 BARS – 30 KW

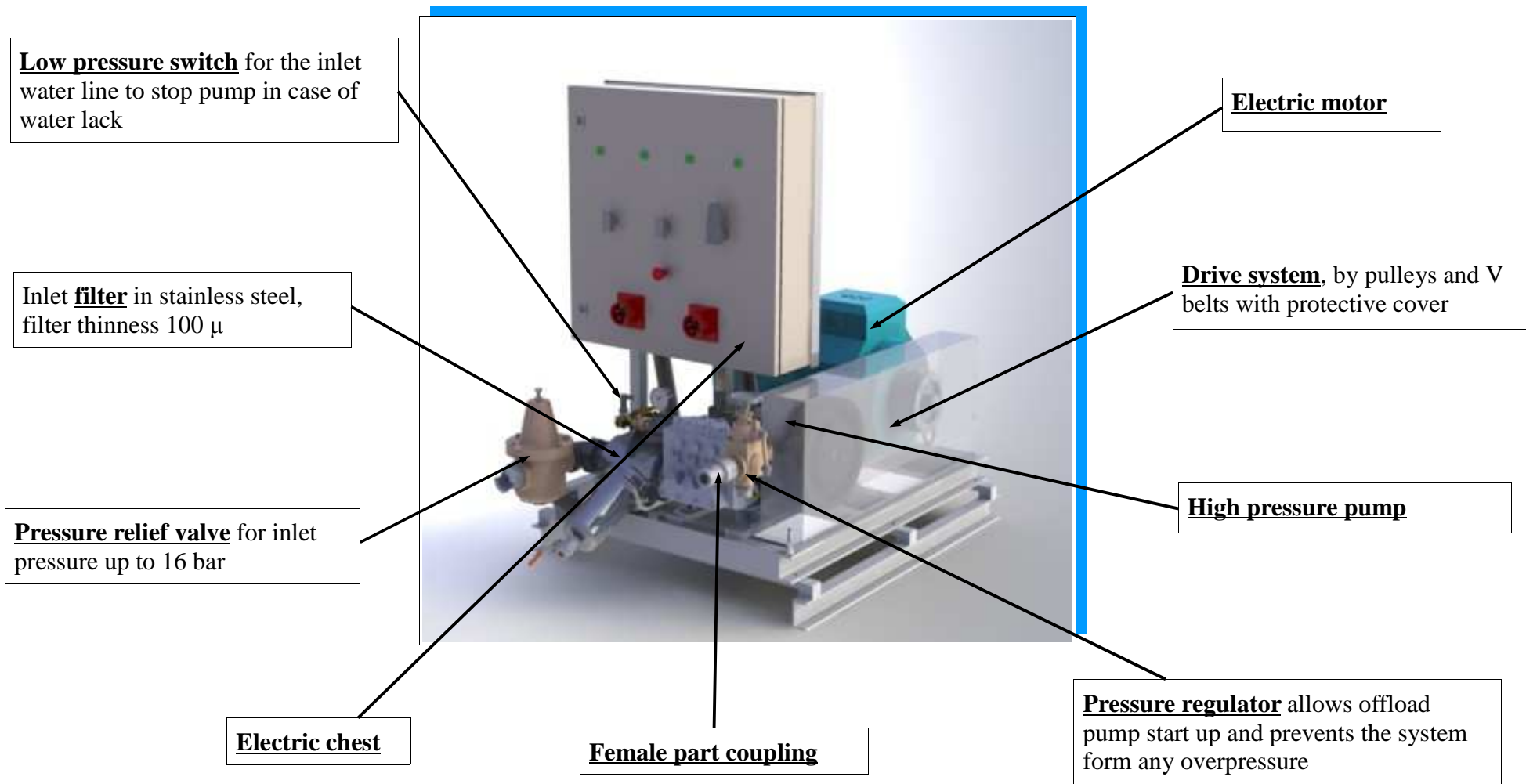

TEST PUMP WITH DIESEL ENGINE
13 L/MIN – 40 BARS – MOTOR 5CV

Safety valve, calibrated
for working pressure

Diesel engine

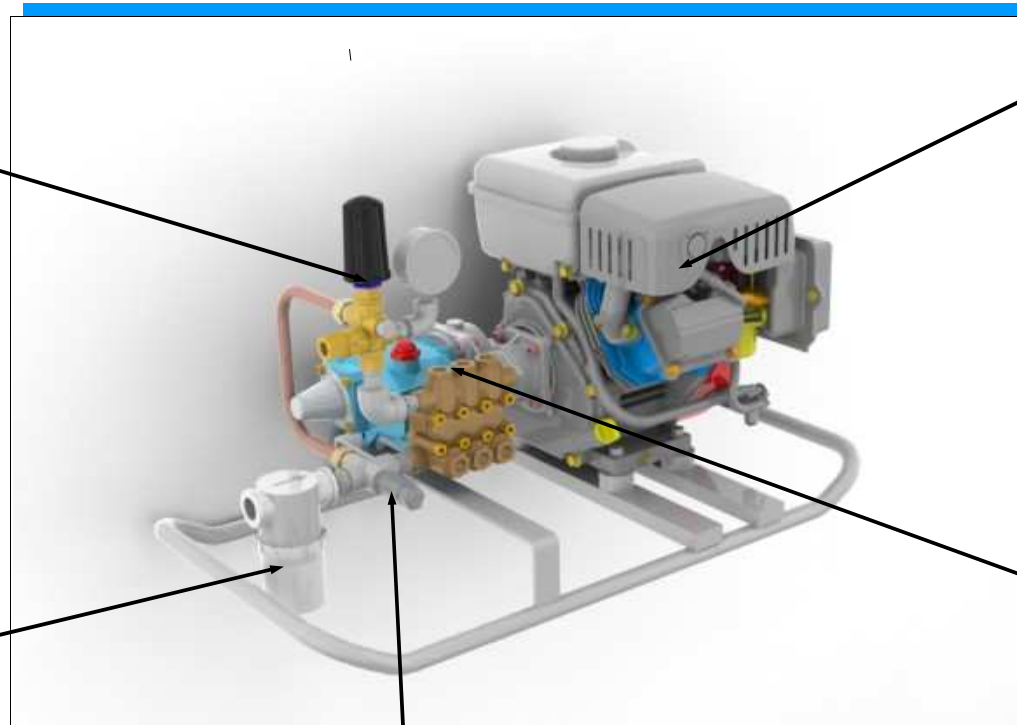

Inlet filter

High pressure pump

Thermostat to stop pump in
case of high temperature

7 L/MIN - 350 BARS – 7,5 KW

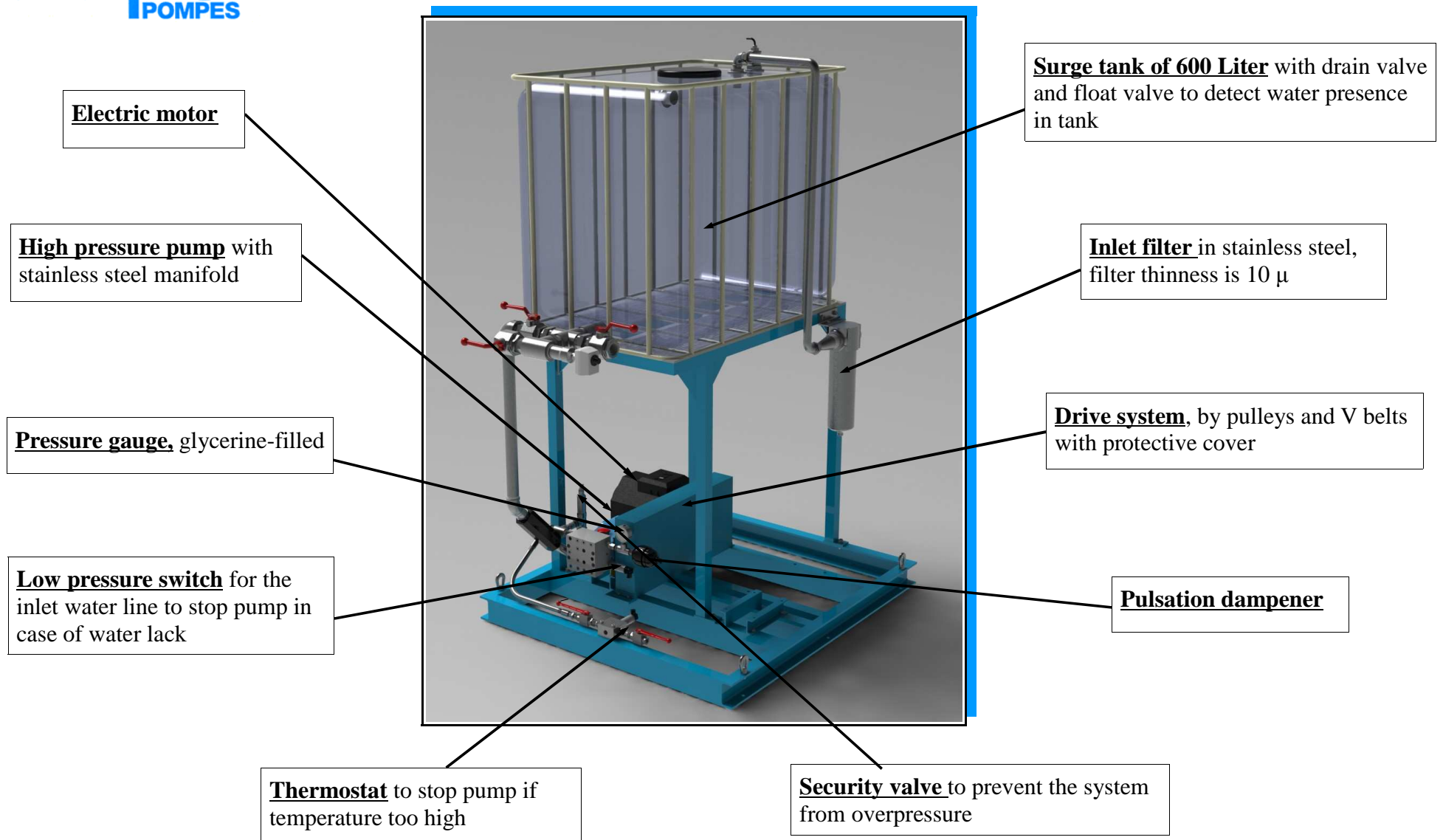

87 L/MIN – 120 BARS – 15 KW

Drive system by pulleys and V belts with protective cover

Electric motor ATEX

Welded steel frame
« umbrella » to protect from rain

Check valve

Pressure gauge,
glycerine-filled

Safety valve calibrated for working pressure

Pulsation dampener

High pressure pump

