







- 

Integrierte Absturz- und Auflaufsicherung
Integrated derailment and bumping protection
Avec anti-chute et anti-basculément
- 

Verzinkte Lastbolzen, Einstellscheiben und Befestigungsmuttern
Zinc plated load bars, washers and locking nuts
Traverses, entretoises et bagues zinguées
- 

Leicht verfahrbar durch kugelgelagerte Laufrollen
Excellent traverse travel ability due to wheels in ball bearing
Galets avec roulements à billes sans entretien
- 

Laufrollenprofil passend für alle Normträger
Adjustable to all standard beam sizes
Adaptable sur tous profils de roulement standard
- 

Deutsche Herstellung
Manufactured in Germany
Fabrication Européenne

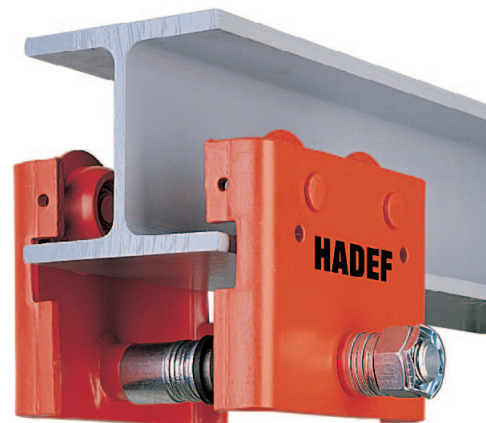

Tragfähigkeit Capacity Capacité	Flanschbreite von - bis bei Lastbolzengröße Flange width from - to for load bar size Largeur de fer de - à pour traverse		Kurvenradius min. min. curve radius Radius de courbe min.		Gewicht Weight Poids	
	1N mm	2N mm	Standard Fahrwerk	modifiziertes Fahrwerk	ca. kg approx. kg env. kg	ca. kg approx. kg env. kg
			standard trolley modèle standard	modified trolley modèle modifié		
kg			m	m ^{(1) (2)}		
500	50 - 146	147 - 302	0,5	-	4,1	4,5
1000	50 - 179	180 - 310	1,3	0,9	6,8	8,5
1500	50 - 173	174 - 316	1,5	0,9	7,8	9,9
2000	50 - 173	174 - 316	1,5	0,9	7,8	9,9
2500	66 - 186	187 - 310	5,0	1,3	16,6	19,9
3200	66 - 186	187 - 310	5,0	1,3	16,6	19,9
5000	74 - 182	183 - 310	5,0	1,8	31,5	39,4
6300	74 - 164	165 - 310	5,0	1,8	31,5	39,4
7500	119 - 189	190 - 310	6,0	2,25	69	71
10000	119 - 160	161 - 310	6,0	2,25	88	91

(1) Optional gegen Mehrpreis./ As option for add. price./ Option pour prix additionnel.

(2) noch kleinere Kurvenradien mit Drehschemelfahrwerk./ Smaller curve radius with swivelling trolley./ Radius de courbe plus petit avec boogie.





19/90

Einschienen-Rollfahrwerk/ Monorail Push Travel Trolley
Chariot manuelle à pousser

ISO 9001
certified company

PREMIUM LINE

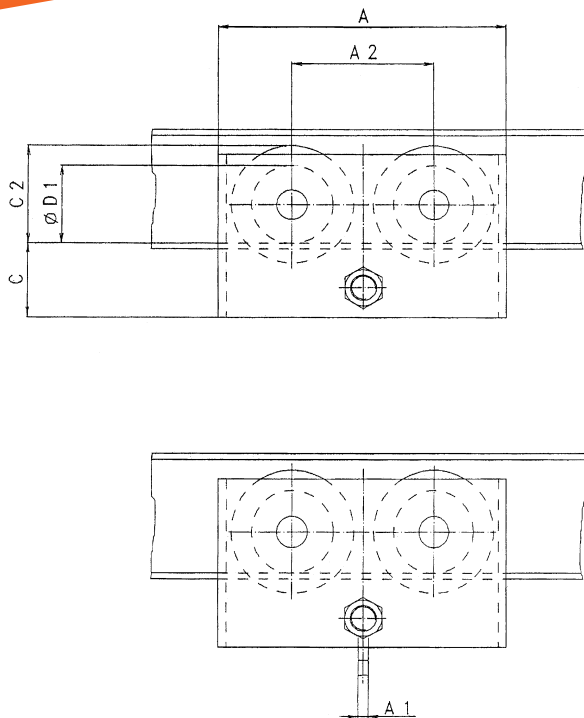

Lastbolzen Größe 1 N
load bar size 1 N
traverse 1 N

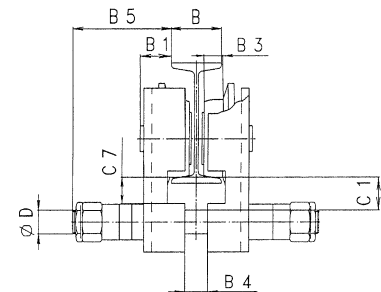

Lastbolzen Größe 2 N
load bar size 2 N
traverse 2 N

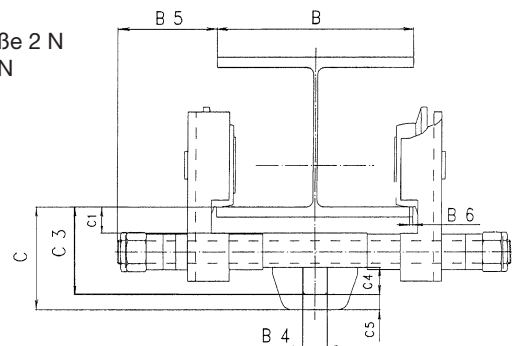

Tragfähigkeit Capacity Capacité kg	Flanschbreite B von/ bis Flange width B from/ to Largeur de fer B de - à mm	Lastbolzen Load bar Traverse Größe size taille	Hauptabmessungen in mm Main dimensions in mm Dimensions principales en mm																			
			A	A1	A2	B1	B3	B4	B5	B6	C	C1	C2	C3	C4	C5	C7	D	D1			
			500	50 - 146 147 - 302	1 N 2 N	165	- 10	75	24	20	26	97 127	7	75 113	46 39	55	- 96	- 28	- 17	28	18	50
			1000	50 - 179 180 - 310	1 N 2 N	232	- 12	110	31	20	32	126	7	118 151	69 56	78	- 134	- 33	- 17	40	24	65
1500	50 - 173 174 - 316	1 N 2 N	240	- 12	110	35	20	36	141	7	118 166	65 54	78	- 144	- 40	- 22	38	30	65			
2000	50 - 173 174 - 316	1 N 2 N	240	- 12	110	35	20	36	141	7	118 166	65 54	78	- 144	- 40	- 22	38	30	65			
2500	66 - 186 187 - 310	1 N 2 N	315	- 15	148	44	23	46	149 152	10	134 200	76 63	99	- 170	- 52	- 30	43	36	83			
3200	66 - 186 187 - 310	1 N 2 N	315	- 15	148	44	23	46	149 152	10	134 200	76 63	99	- 170	- 52	- 30	43	36	83			
5000	74 - 182 183 - 310	1 N 2 N	435	- 20	211	53	28	52	153 167	13	150 229	85 73	135	- 194	- 62	- 35	40	39	120			
6300	74 - 164 165 - 310	1 N 2 N	435	- 20	211	53	28	52	153 167	13	150 229	85 73	135	- 194	- 62	- 35	40	39	120			
7500	119 - 189 190 - 310	1 N 2 N	494	- 30	230	69	40	74	183 211	15	220 323	136 115	168	- 278	- 80	- 45	45	48	150			
10000	119 - 160 161 - 310	1 N 2 N	494	- 30	230	69	40	74	183 211	15	220 323	136 115	168	- 278	- 80	- 45	45	48	150			



19/90

HADEF®



Einschienen-Rollfahrwerk/ Monorail Push Travel Trolley
Chariot manuelle à pousser

ISO 9001
certified company

PREMIUM LINE

+ Optionen/ Options / Options

Drehschemelfahrwerk für sehr
kleine Kurvenradien
Swivelling trolley for very small
curve radius
Boogie pour radius de courbe
plus petite

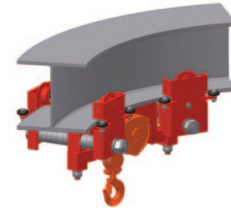

größere Flanschbreiten möglich
larger flange width available
largeur de fer plus grande possible



Feststellvorrichtung
Beam locking device
Dispositif de blocage sur fer

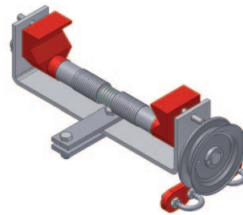

Gummipuffer
Rubber end stops
Butées caoutchouc

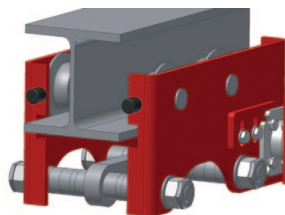

Komplett verzinkte Ausführung
Totally zinc plated trolley
Réalisation entièrement zinguée



Ausführung
version
version **ATEX**

